



General Purpose Fuses IEC



General Purpose Fuses IEC



Ferrule Fuses aM & gG 400V to 690V with/without Striker aM & gG 8x32, 10x38, 14x51, 22x58

Residential and Industrial Cylindrical Fuse-links

Ferraz Shawmut gF/gG-gG and aM fuse-links cover a wide range of physical sizes and ampere ratings for 250, 380*/ 400, 500, and 660* 690volts AC. gF/gG fuse-links are for residential use. gG and aM fuse-links are for industrial applications. Most ratings are available with an optional indicator. All industrial fuse-links have the option of a built-in striker. All cylindrical fuse-links have ceramic bodies and silver-plated ferrules.

** Fuse-links marked 380V (gF/gG) and 660V (gG-aM) will be re-marked (and safely used at) 400V AC and 690V AC in compliance with changes in IEC Standard 269, but should not be used above 418V AC or 726V AC.*

gF/gG

Residential Full Range Protection

- 7 physical sizes from 6.3 x 23mm to 10.3 x 38 mm
- 250 and 380 Volt ratings - 0.5A through 32A
- Most ratings available with indicator
- Meet IEC, NFC, UNE standards
- See residential fuse-links, Special Purpose section

gG

Full Range Protection

- 4 physical sizes from 8 x 31mm to 22 x 58 mm
- 400, 500 and 690 Volt ratings -0.5A through 125A
- Most ratings available with indicator
- Meet IEC, NFC and UNE standards
- Approved by Lloyds Register of Shipping and Bureau Veritas

gG

Full Range Protection

Fuse-links with striker

- 2 sizes- 14 x 51mm and 22 x 58 mm
- 400, 500 and 690 Volt ratings 4A through 125A
- All ratings include striker
- Meet IEC, NFC and UNE standards
- Approved by Lloyds Register of Shipping and Bureau Veritas

aM

Short Circuit Protection

Fuse-links with striker

- 4 physical sizes from 8 x 31 mm to 22 x 58 mm
- 400, 500 and 690 Volt ratings- 0.16A through 125A
- Most ratings available with indicator
- Meet IEC, NFC and UNE standards
- Approved by Lloyds Register of Shipping and Bureau Veritas

aM

Short Circuit Protection

Fuse-links with striker

- 2 sizes - 14 x 51mm and 22 x 58mm
- 400, 500 and 690 Volt ratings - 2A through 125A
- All ratings include striker
- Meet IEC, NFC and UNE standards
- Approved by Lloyds Register of Shipping and Bureau Veritas

General Purpose Fuses IEC

Ferrule Fuses
gG 400V to 690V
with/without Striker
gG 8x32, 10x38, 14x51, 22x58

Ratings - gG (Optional Blown-Fuse Indicator)

Size	Rated In Current (A)	Rated Voltage	Previous References		Reference Number		Breaking Capacity	Catalog Number	
			w/o Indicator	w Indicator	w/o Indicator	w Indicator		w/o Indicator	w Indicator
8 x 31	0.5	400V	15009	-	P218191	-	20kA - 400V	FR8GG40V0.5	
	1		15011	-	C218709			FR8GG40V1	
	2		15013	15213	Q219227	B222204		FR8GG40V2	FR8GG40V2I
	4		15019	15219	W222958	X222959		FR8GG40V4	FR8GG40V4I
	6		15023	15223	A211025	V201291		FR8GG40V6	FR8GG40V6I
	8		15027	15227	B213096	B211026		FR8GG40V8	FR8GG40V8I
	10		15031	15231	A214613	A212060		FR8GG40V10	FR8GG40V10I
	12		15033	15233	R216146	C213097		FR8GG40V12	FR8GG40V12I
	16		15035	15235	P216650	Y214105		FR8GG40V16	FR8GG40V16I
	20		15037	15237	F217677	J215127		FR8GG40V20	FR8GG40V20I
25	15039	15239	D218710	S216147	FR8GG40V25	FR8GG40V25I			
10 X 38	0.5	500V	16009	-	C211027	-	120kA - 500V	FR10GG50V0.5	FR10GG50V2I
	1		16011	-	B212061	-		FR10GG50V1	FR10GG50V4I
	2		16013	16213	D213098	S216653		FR10GG50V2	FR10GG50V6I
	4		16019	16219	X213598	E217170		FR10GG50V4	FR10GG50V10I
	6		16023	16223	K215128	T218195		FR10GG50V6	FR10GG50V10I
	8		16027	16227	D217169	V219231		FR10GG50V8	FR10GG50V12I
	10		16031	16231	S218194	E222207		FR10GG50V10	FR10GG50V16I
	12		16033	16233	W219761	H200751		FR10GG50V12	FR10GG50V20I
	16		16035	16235	G200750	H201809		FR10GG50V16	FR10GG50V25I
	20		16037	16237	D211028	X211551		FR10GG50V20	FR10GG50V32I
25	16039	16239	E213099	W212585	FR10GG50V25	FR10GG50V2I			
32	400V	16043	16243	A214107	Z213600	120kA - 400V	FR10GG50V32	FR10GG50V4I	
14 X 51	1	690V	17011	-	K218716	-	80kA - 690V	FR14GG69V1	
	2		17013	17213	Y219234	C201298		FR14GG69V2	FR14GG69V2I
	4		17019	17219	A219765	H211032		FR14GG69V4	FR14GG69V4I
	6		17023	17223	H222210	G212066		FR14GG69V6	FR14GG69V6I
	8		17027	17227	D222965	K213104		FR14GG69V8	FR14GG69V8I
	10		17031	17231	L200754	H214620		FR14GG69V10	FR14GG69V10I
	12		17033	17233	L201812	R215640		FR14GG69V12	FR14GG69V12I
	16		17035	17235	A211554	X216657		FR14GG69V16	FR14GG69V16I
	20		17037	17237	Z212588	N217684		FR14GG69V20	FR14GG69V20I
	25		17039	17239	C213603	M218718		FR14GG69V25	FR14GG69V25I
32	500V	17043	17243	W216656	C219767	120kA - 500V	FR14GG69V32	FR14GG69V32I	
40		17047	17247	X218198	F222967	FR14GG69V40	FR14GG69V40I		
50	400V	17051	17251	Z219235	D201299	120kA - 400V	FR14GG69V50	FR14GG69V50I	
22 x 58	2	690V	18013	-	F219241	-	80kA - 690V	FR22GG69V2	
	4		18019	18219	H219772	Q211039		FR22GG69V4	FR22GG69V4I
	6		18023	18223	P222216	P212073		FR22GG69V6	FR22GG69V6I
	8		18027	18227	L222972	R213110		FR22GG69V8	FR22GG69V8I
	10		18031	18231	T200761	N214119		FR22GG69V10	FR22GG69V10I
	12		18033	18233	J201304	Y215140		FR22GG69V12	FR22GG69V12I
	16		18035	18235	S201818	D216157		FR22GG69V16	FR22GG69V16I
	20		18037	18237	P211038	R217181		FR22GG69V20	FR22GG69V20I
	25		18039	18239	N212072	F218206		FR22GG69V25	FR22GG69V25I
	32		18043	18243	F212594	H219243		FR22GG69V32	FR22GG69V32I
	40		18047	18247	J213609	R222218		FR22GG69V40	FR22GG69V40I
	50		18051	18251	P214626	W200763		FR22GG69V50	FR22GG69V50I
	63		18055	18255	Y215646	V201820		FR22GG69V63	FR22GG69V63I
	80		18059	18259	Q217180	K211563		FR22GG69V80	FR22GG69V80I
	100		500V	18063	18263	E218205		H212596	120kA - 500V
125	400V	18065	18265	J219773	L213611	120kA - 400V	FR22GG69V125	FR22GG69V125I	

Packaging 10



X211551



M218718



K211563

Blown-Fuse Indicator

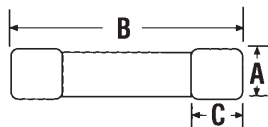

Dimensions

Fuse Size	A	B	C
8 x 31	8.5	31.5	6.3
10 x 38	10.3	38	10.5
14 x 51	14.3	51	13.8
22 x 58	22.2	58	16.2

General Purpose Fuses IEC

Ferrule Fuses gG 400V to 690V with/without Striker gG 8x32, 10x38, 14x51, 22x58

Ratings – gl-gG with Striker



P201815



R212075

Size (mm x mm)	Rated Current In (A)	Rated Voltage	Previous Reference	Reference Number	Breaking Capacity	Catalog Number		
14 X 51	2	500V	17413	J211033	120kA - 500V	FR14GG69V2P		
	4		17419	H212067		FR14GG69V4P		
	6		17423	G214113		FR14GG69V6P		
	8		17427	R215134		FR14GG69V8P		
	10		17431	Z216153		FR14GG69V10P		
	12		17433	L217176		FR14GG69V12P		
	16		17435	Z218200		FR14GG69V16P		
	20		17437	B219237		FR14GG69V20P		
	25		17439	L222213		FR14GG69V25P		
	32		17443	P200757		FR14GG69V32P		
22 X 58	40	690V	17447	P201815	80kA - 690V	FR14GG69V40P		
	50		17451	D211557		FR14GG69V50P		
	4		18419	R214628		FR22GG69V4P		
	6		18423	A215648		FR22GG69V6P		
	8		18427	F216665		FR22GG69V8P		
	10		18431	W217691		FR22GG69V10P		
	12		18433	W218726		FR22GG69V12P		
	16		18435	L219775		FR22GG69V16P		
	20		18437	P222975		FR22GG69V20P		
	25		18439	M201307		FR22GG69V25P		
22 X 58	32	500V	18443	S211041	120kA - 500V	FR22GG69V32P		
	40		18447	R212075		FR22GG69V40P		
	50		18451	M213612		FR22GG69V50P		
	63		18455	S214629		FR22GG69V63P		
	80		18459	F216159		FR22GG69V80P		
	100		18463	T217183		FR22GG69V100P		
	125		18465	H218208		FR22GG69V125P		
			400V				120kA - 400V	

Packaging 10

Dimensions

Fuse Size	A	B	C	D	E
14 x 51	14.3	51	13.8	7.5	3.8
22 x 58	22.2	58	16.2	7.5	3.8

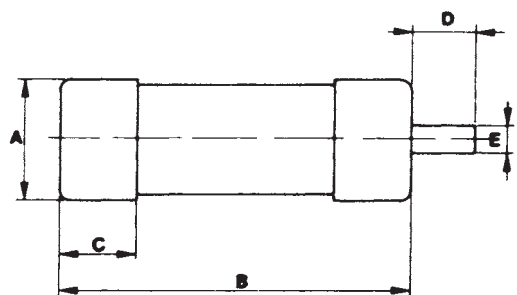

Striker



- 1 Ceramic body
- 2 Sand
- 3 Indicator contact
- 4 Lower contact
- 5 Contact ring
- 6 Melting element
- 7 Indicator

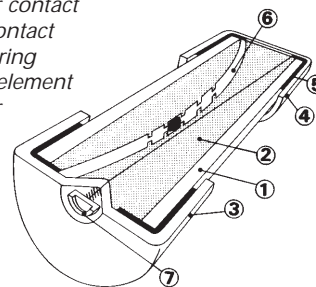

Neutral

Size (mm x mm)	Previous Reference	Reference Number	Standard Pack/CTN	Catalog Number
10 x 38	19100	R211569		FRN1038
14 x 51	19200	M212600	10	FRN1451
22 x 58	19300	R213616		FRN2258

General Purpose Fuses IEC

Ferrule Fuses
 gG 400V to 690V
 with/without Striker
 gG 8x32, 10x38, 14x51, 22x58

Characteristics t-I

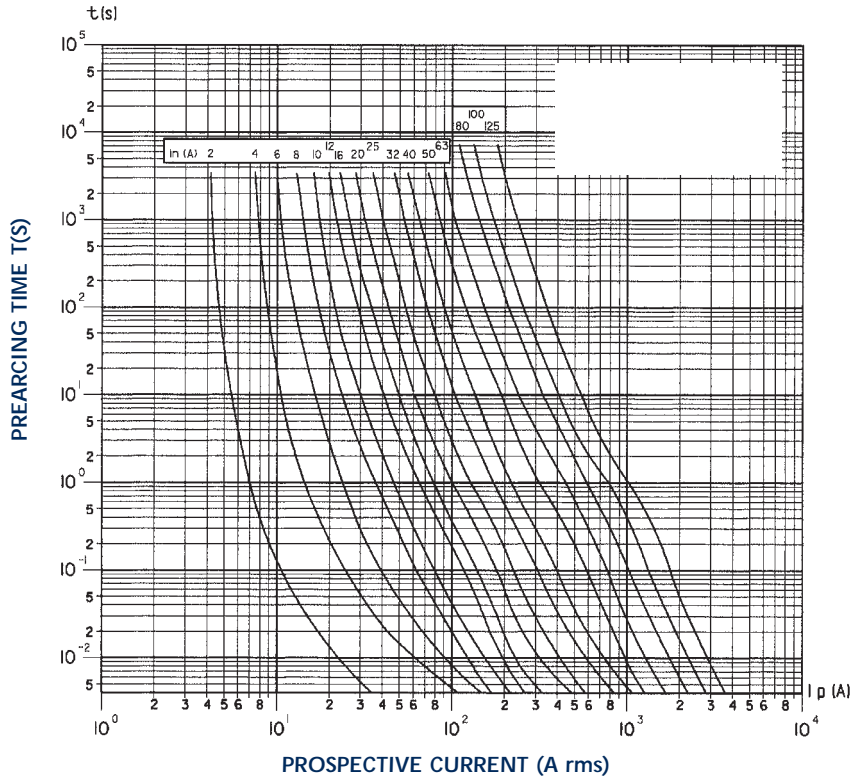

Cut-off characteristics

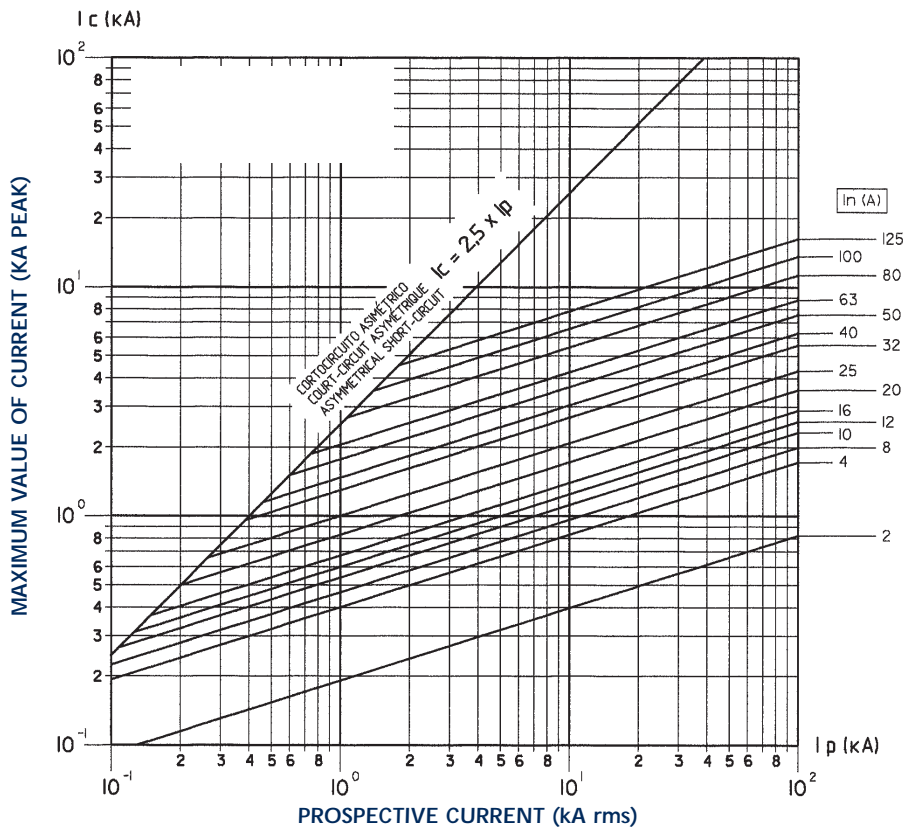

General Purpose Fuses IEC

Ferrule Fuses
 gG 400V to 690V
 with/without Striker
 gG 8x32, 10x38, 14x51, 22x58

Characteristics I2t

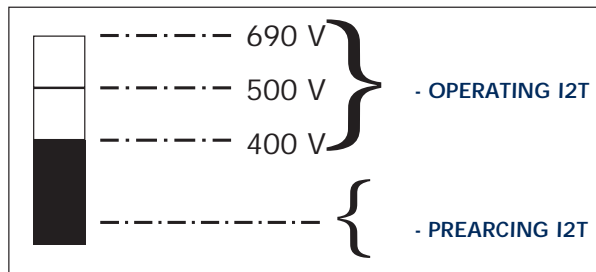
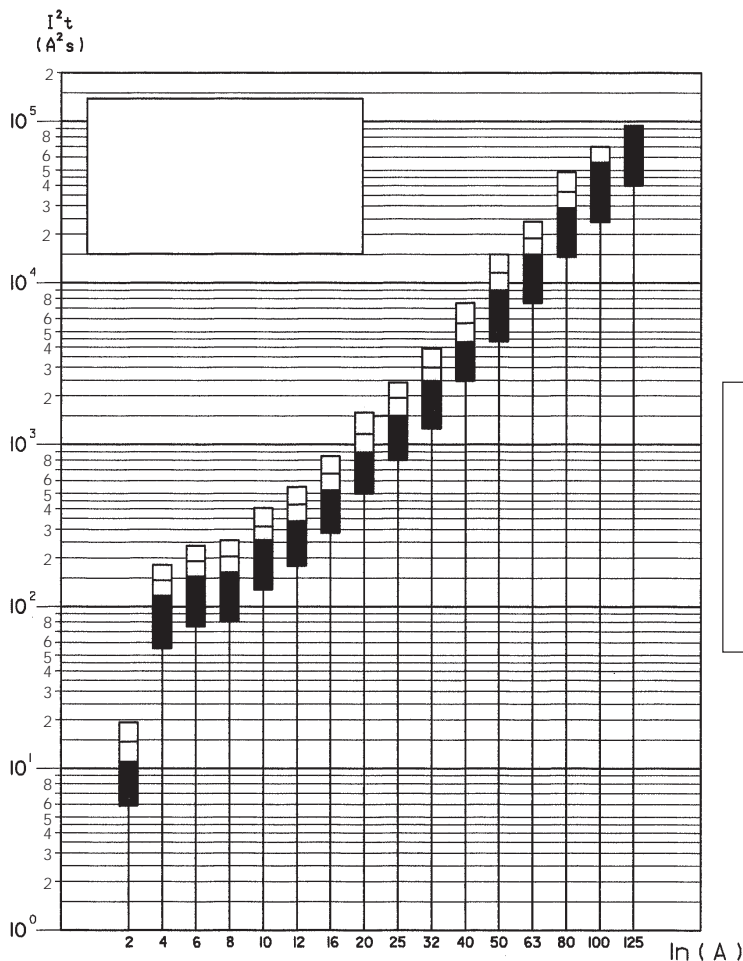
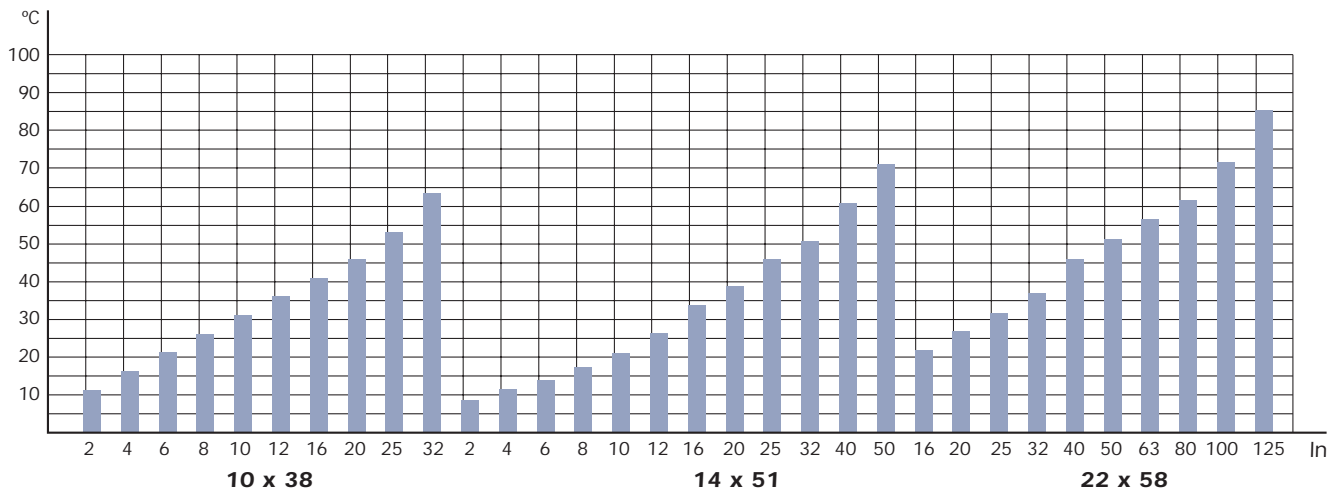

Table temperature increase (testing in superior contact)



General Purpose Fuses IEC

Ferrule Fuses gG 400V to 690V with/without Striker gG 8x32, 10x38, 14x51, 22x58

Power loss table

In	Size		
	10 x 38	14 x 51	22 x 58
0,5 A	2 W		
1 A	2,5 W	3,4 W	
2 A	0,70 W	1 W	1,20 W
4 A	0,80 W	1,10 W	1,30 W
6 A	0,90 W	1,20 W	1,40 W
8 A	1,10 W	1,50 W	1,65 W
10 A	1,35 W	1,80 W	2 W
12 A	1,55 W	2,10 W	2,40 W
16 A	1,90 W	2,55 W	3 W
20 A	2,30 W	3 W	3,40 W
25 A	2,80 W	3,50 W	3,80 W
32 A	3 W	3,80 W	4,30 W
40 A		4,40 W	5,10 W
50 A		4,7 W	5,50 W
63 A			6,70 W
80 A			8 W
100 A			9 W
125 A			12,5 W

Maximum standardized power low.

IEC 269-2-1	10 x 38	14 x 51	22 x 58
NFC 63.213	25 A	40 A	100 A
UNE 21.103-2-1	3 W	5 W	9,5 W

Table of maximum length of network in function of In and conductor section.
Maximum standardized power low.

gG Class Fuses

Copper conductor section (mm ²)	Rated Current (In) OF gG Fuses (in A)									
	16	20	25	32	40	50	63	80	100	125
1,5	99/113	86/87	40/59	21/29	13/16	7/9				
2,5		134	110/122	67/84	41/51	25/33	13/20	8/11		
4			183	139	108/119	67/84	46/58	24/32	14/17	7,3/10
6				214	165	139	94/113	55/70	33/41	20/27
10					275	226	172	130	90/108	57/70
16							283	217	168	128
25								336	257	197
35									367	283
50										379

* 99/118:

- 99; Cond. PVC / 118; Cond. PRC

General Purpose Fuses IEC

Ferrule Fuses aM 400V to 690V with/without Striker aM 8x32, 10x38, 14x51, 22x58

Ratings - aM (Optional Blown-Fuse Indicator)

Size (mm x mm)	Rated In Current (A)	Rated Voltage	Previous Reference		Reference Number		Breaking Capacity	Catalog Number		
			w/o Indicator	w Indicator	w/o Indicator	w Indicator		w/o Indicator	w Indicator	
8 x 31	400V	400V	15511	-	C217168	-	20kA - 400V	FR8AM40V1		
			15513	-	R218193	-		FR8AM40V2		
			15519	-	S219229	-		FR8AM40V4		
			15523	-	C222205	-		FR8AM40V6		
			15527	-	F200749	-		FR8AM40V8		
			15531	-	W201292	-		FR8AM40V10		
10 X 38	500V	500V	16503	-	E214617	-	120kA - 500V	FR10AM50V0.16		
			16507	-	M215130	-		FR10AM50V0.25		
			16509	-	W216150	-		FR10AM50V0.5		
			16511	16711	F217171	X219233		FR10AM50V1	FR10AM50V11	
			16513	16713	H218714	G222209		FR10AM50V2	FR10AM50V21	
			16519	16719	W219232	K200753		FR10AM50V4	FR10AM50V41	
	400V	400V	16523	16723	F222208	K201811	FR10AM50V6	FR10AM50V61		
			16527	16727	Z201295	Z211553	FR10AM50V10	FR10AM50V101		
			16531	16731	Y211552	H213102	FR10AM50V10	FR10AM50V101		
			16533	16733	A213601	D214110	FR10AM50V12	FR10AM50V121		
			16535	16735	F214618	P215132	FR10AM50V16	FR10AM50V161		
			16537	16737	X216151	V216655	FR10AM50V20	FR10AM50V201		
14 X 51	400V	400V	16539	16739	G217172	L217682	120kA - 400V	FR10AM50V25	FR10AM50V251	
			16543	-	J218715	-		FR10AM50V32		
			17507	-	B212590	-		FR14AM69V0.25		
			17509	-	L213105	-		FR14AM69V0.5		
			17511	17711	E213605	C212591		FR14AM69V1	FR14AM69V11	
			17513	17713	H214114	M213106		FR14AM69V2	FR14AM69V21	
	690V	690V	17519	17719	K214622	J214115	80kA - 690V	FR14AM69V4	FR14AM69V41	
			17523	17723	S215135	T215136		FR14AM69V6	FR14AM69V61	
			17527	17727	T215642	A216660		FR14AM69V8	FR14AM69V81	
			17531	17731	Z216659	R217687		FR14AM69V10	FR14AM69V101	
			17533	17733	M217177	Q218721		FR14AM69V12	FR14AM69V121	
			17535	17735	Q217686	F219770		FR14AM69V16	FR14AM69V161	
		500V	500V	17537	17737	P218720	R200759	120kA - 500V	FR14AM69V20	FR14AM69V201
				17539	17739	E219769	Q201816		FR14AM69V25	FR14AM69V251
				17543	17743	M222214	F211559		FR14AM69V32	FR14AM69V321
				17547	17747	Q200758	D212592		FR14AM69V40	FR14AM69V401
				17549	17749	L211035	G213607		FR14AM69V45	FR14AM69V451
				17551	17751	E211558	M214624		FR14AM69V50	FR14AM69V501
690V	690V	18511	-	M219776	-	120kA - 400V	FR22AM69V1			
		18513	-	T222220	-		FR22AM69V2			
		18519	18719	Q222976	L219246		FR22AM69V4	FR22AM69V41		
		18523	18723	Y200765	V222221		FR22AM69V6	FR22AM69V61		
		18527	18727	N201308	Y201823		FR22AM69V8	FR22AM69V81		
		18531	18731	X201822	N211566		FR22AM69V10	FR22AM69V101		
	500V	500V	18533	18731	T211042	K212598	80kA - 690V	FR22AM69V12	FR22AM69V121	
			18535	18735	M211565	P213614		FR22AM69V16	FR22AM69V161	
			18537	18737	S212076	V214631		FR22AM69V20	FR22AM69V201	
			18539	18739	J212597	D215651		FR22AM69V25	FR22AM69V251	
			18543	18743	V213113	J216668		FR22AM69V32	FR22AM69V321	
			18547	18747	N213613	Z217694		FR22AM69V40	FR22AM69V401	
400V	400V	18551	18751	R214122	P219778	120kA - 500V	FR22AM69V50	FR22AM69V501		
		18555	18755	C215650	Z200766		FR22AM69V63	FR22AM69V631		
		18559	18759	H216667	P211567		FR22AM69V80	FR22AM69V801		
		18563	18763	Y217693	L212599		FR22AM69V100	FR22AM69V1001		
		18565	18765	J218209	W214632		FR22AM69V125	FR22AM69V1251		
		18565	18765	J218209	W214632		FR22AM69V125	FR22AM69V1251		

Packaging 10

Blown-Fuse Indicator

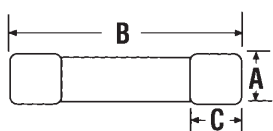

Dimensions

FUSE SIZE	A	B	C
8 x 31	8.5	31.5	6.3
10 x 38	10.3	38	10.5
14 x 51	14.3	51	13.8
22 x 58	22.2	58	16.2

General Purpose Fuses IEC

Ferrule Fuses
 aM 400V to 690V
 with/without Striker
 aM 8x32, 10x38, 14x51, 22x58

Ratings - aM with Striker



X215645



K216669

Size (mm x mm)	Rated Current In (A)	Rated Voltage	Previous Reference	Reference Number	Breaking Capacity	Catalog Number
14 X 51	1	500V	17911	W215644	120kA 500V	FR14AM69V1P
	2		17913	B216661		FR14AM69V2P
	4		17919	C218203		FR14AM69V4P
	6		17923	E219240		FR14AM69V6P
	8		17927	N222215		FR14AM69V8P
	10		17931	S200760		FR14AM69V10P
	12		17933	R201817		FR14AM69V12P
	16		17935	G211560		FR14AM69V16P
	20		17937	E212593		FR14AM69V20P
	25		17939	H213608		FR14AM69V25P
	32		17943	N214625		FR14AM69V32P
	40		17947	X215645		FR14AM69V40P
	45	17949	C216662	FR14AM69V45P		
50	400V	17951	D218204	120kA - 400V	FR14AM69V50P	
22 X 58	1	690V	18911	E215652	80kA - 690V	FR22AM69V1P
	2		18913	J216162		FR22AM69V2P
	4		18919	A217695		FR22AM69V4P
	6		18923	Y218728		FR22AM69V6P
	8		18927	Q219779		FR22AM69V8P
	10		18931	S222978		FR22AM69V10P
	12		18933	R201311		FR22AM69V12P
	16		18935	W211044		FR22AM69V16P
	20		18937	W212079		FR22AM69V20P
	25		18939	Q213615		FR22AM69V25P
	32		18943	X214633		FR22AM69V32P
	40		18947	F215653		FR22AM69V40P
	50		18951	K216669		FR22AM69V50P
	63		18955	B217696		FR22AM69V63P
	80		500V	18959		Z218729
	100	18963	T222979	FR22AM69V100P		
125	400V	18965	S201312	120kA - 400V	FR22AM69V125P	

Packaging 10

Dimensions

Fuse Size	A	B	C	D	E
14 x 51	14.3	51	13.8	7.5	3.8
22 x 58	22.2	58	16.2	7.5	3.8

Striker



BEFORE



AFTER

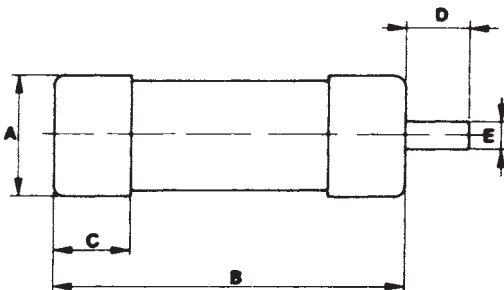

Neutral

Size (mm x mm)	Previous Reference	Reference Number	Standard Pack/CTN	Catalog Number
10 x 38	19100	R211569		FRN1038
14 x 51	19200	M212600	10	FRN1451
22 x 58	19300	R213616		FRN2258

General Purpose Fuses IEC

Ferrule Fuses
 aM 400V to 690V
 with/without Striker
 aM 8x32, 10x38, 14x51, 22x58

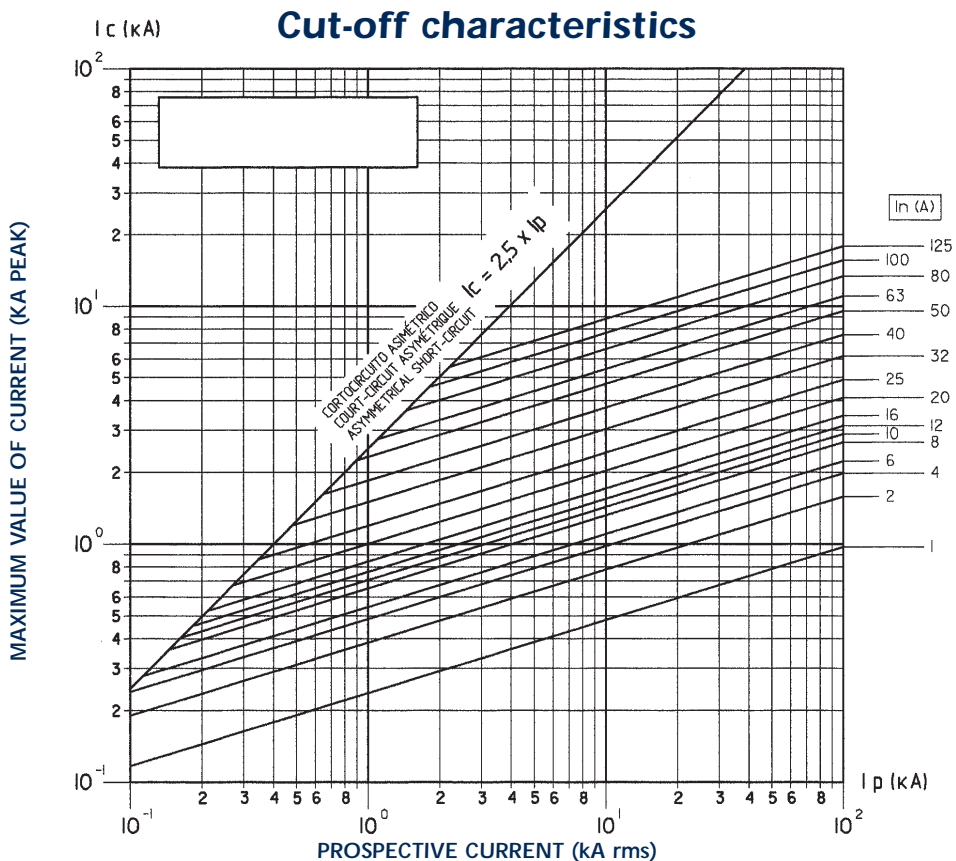
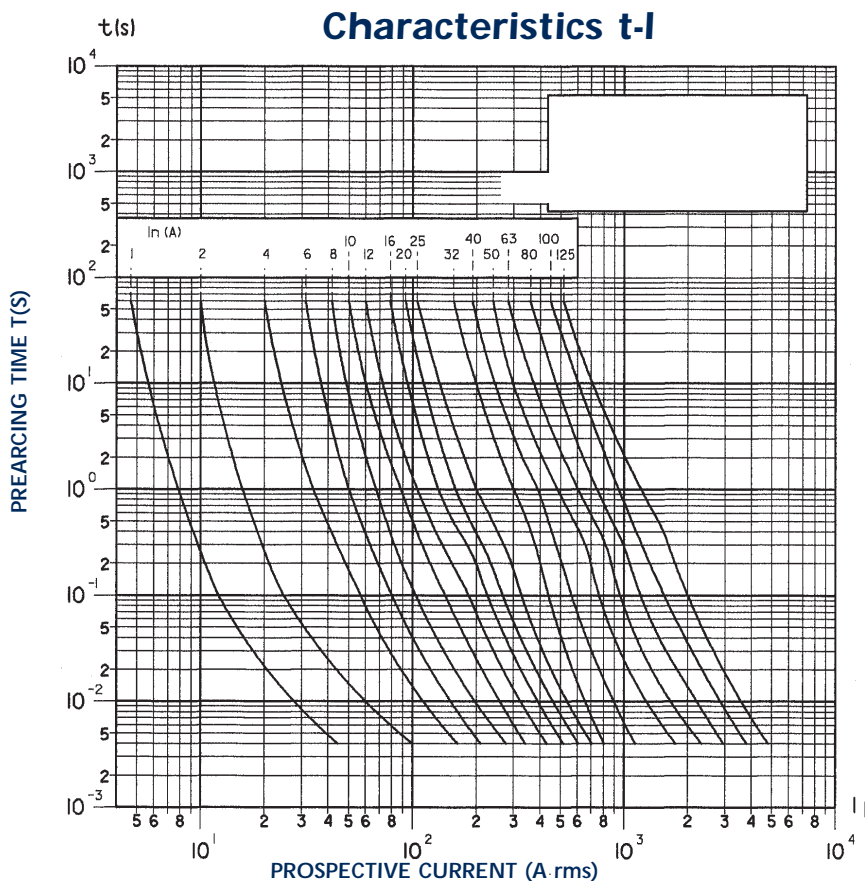

General Purpose Fuses IEC

Ferrule Fuses
 gG 400V to 690V
 with/without Striker
 aM 8x32, 10x38, 14x51, 22x58

Characteristics I²t

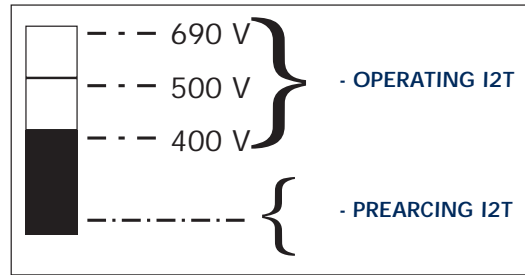
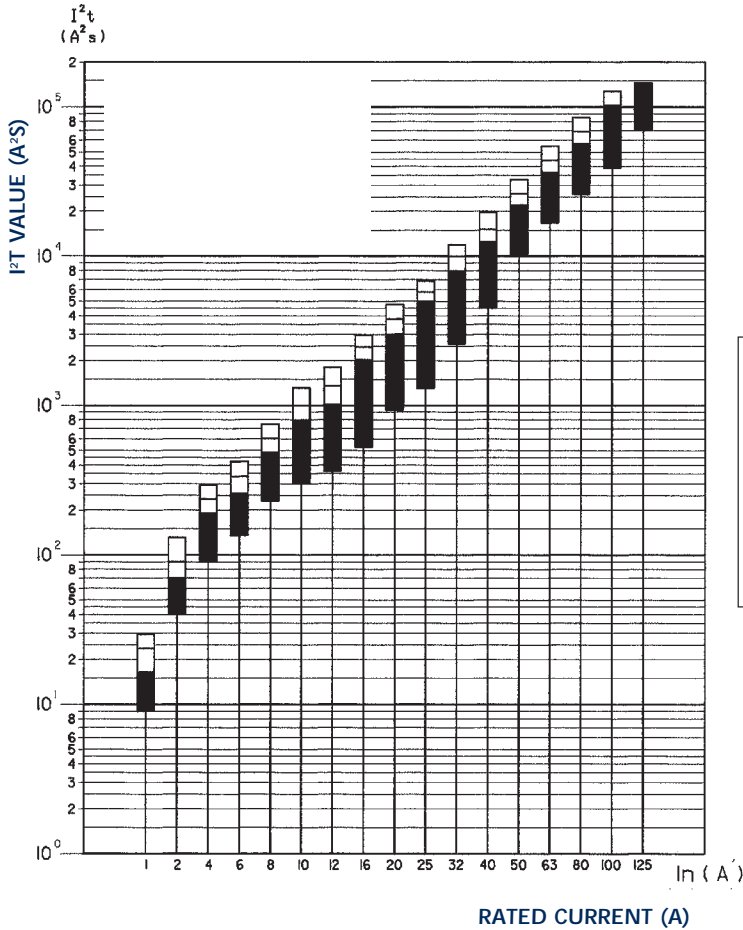

Temperature increase table (testing in superior contact)

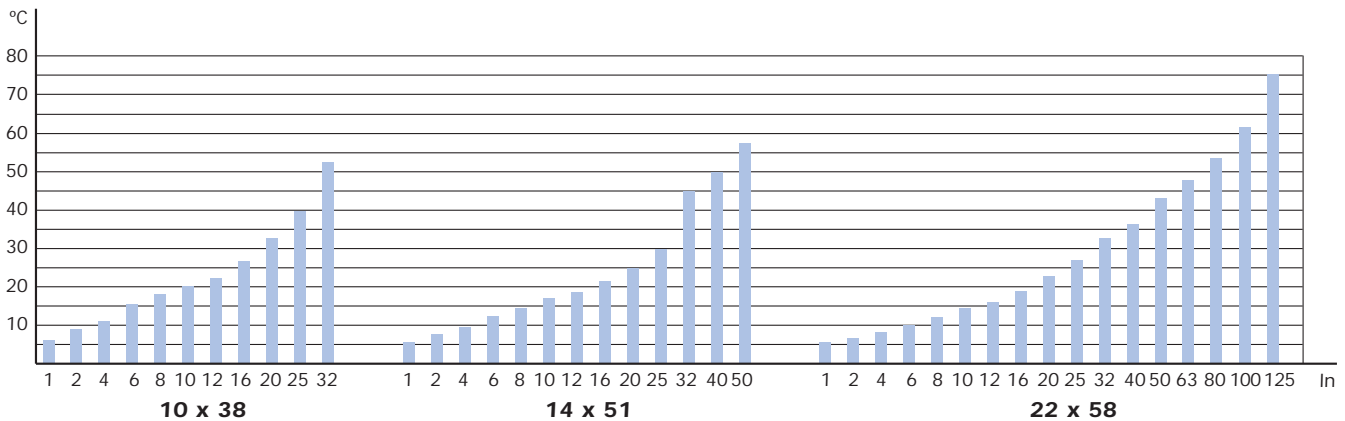

General Purpose Fuses IEC

Ferrule Fuses
aM 400V to 690V
with/without Striker
aM 8x32, 10x38, 14x51, 22x58

Power loss table

In	Size			
	10 x 38	14 x 51	22 x 58	
0,16 A	0,35 W			
0,25 A	0,50 W	0,70 W		
0,5 A	0,50 W	0,75 W		
1 A	0,13 W	0,18 W	0,20 W	
2 A	0,20 W	0,25 W	0,30 W	
4 A	0,30 W	0,40 W	0,50 W	
6 A	0,45 W	0,55 W	0,65 W	
8 A	0,55 W	0,65 W	0,75 W	
10 A	0,65 W	0,75 W	0,85 W	
12 A	0,75 W	0,85 W	1 W	
16 A	0,90 W	1,20 W	1,40 W	
20 A	1,10 W	1,50 W	1,70 W	
25 A	1,40 W	1,80 W	2 W	
32 A	2 W	2,10 W	2,60 W	
40 A		2,60 W	3,20 W	
45 A		2,80 W		
50 A		2,90 W	3,90 W	
63 A			4,60 W	
80 A			5,60 W	
100 A			6,50 W	
125 A			9,50 W	
Maximum standardized power low.	IEC 269-2-1 NFC 63.213 UNE 21.103-2-1	10 x 38 16 A 1,2 W	14 x 51 50 A 3 W	22 x 58 100 A 7 W

Table of maximum length of network in function of In and conductor section.
Maximum standardized power low.

aM Class Fuses

Copper conductor section (mm ²)	Rated Current (In) OF aM Fuses (in A)									
	16	20	25	32	40	50	63	80	100	125
1,5	55/64	37/45	25/30	15/20						
2,5	116	84/94	58/68	40/49	26/32	17/20				
4	181	147	118	84/95	58/68	42/48	28/33	18/23		
6	273	223	178	139	105/117	79/89	55/64	37/42	26/31	14/20
10				227	181	147	113/125	80/94	57/69	40/47
16						236	189	151	120	83/97
25								231	185	147
35									262	210

General Purpose IEC Fuses



NH Fuses (Plain Blades)
gG 400V, 500V, 690V
aM 500V, 690V

NH Fuse System



DIN 57 636/VDE 0636 Parts 1, 10, 21, 22, 201
IEC 60269-2
DIN 43 620 Parts 1 to 4 (Standard dimensions)

The use category is identified by two letters, the first indicating the operational class and the second the object to be protected. The Ferraz shawmut range includes fuse-links to DIN VDE 0636 standard for the following uses categories:

- gG: general purpose cable and line protection
- aM: Partial purpose, motor circuit protection
- gTr: general purpose, transformer protection
- gR: general purpose, fast acting
- aR: partial purpose, fast acting

Classification

The NH system is classed among plug-in fuse systems and is comprised of:

- fuse-base, (possibly including terminal covers and phase barriers)
- fuse-link with blade contact
- fuse-link replacement device (LV HRC fuse puller)

Since the design of this system cannot guarantee non-interchangeability of rated current, it must be handled by a qualified professional.

Approval symbols



Germany



Austria



Switzerland



Netherlands



Beige melted



Red non melted

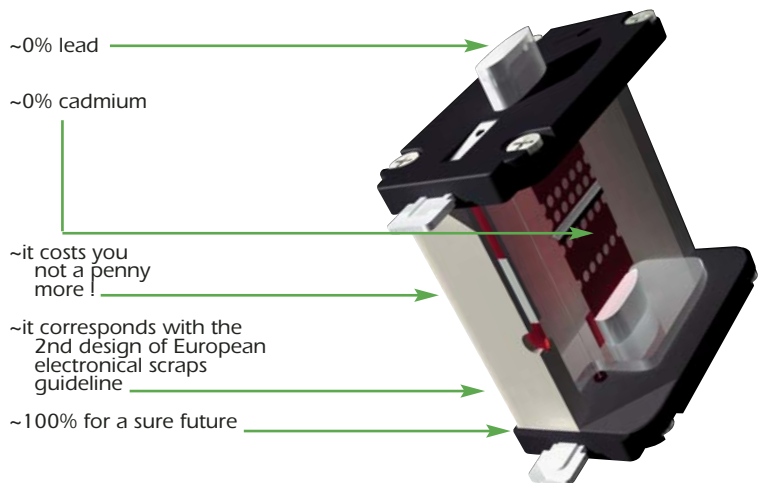

General Purpose IEC Fuses

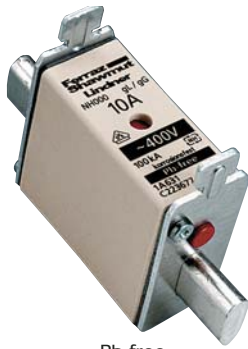

Pb-free

NH Fuses (Plain Blades) gG 400V, 500V, 690V gG 400V Size 000 to 3

NH-fuses, 400VAC gG

with non-isolated gripping lugs, double indicator, contact blades, complying with DIN VDE 0636Part 201 and IEC 60269-2-1

Size	Rated current I_N (A)	Power dissipation (W)	FS ref.-no.	Previous ref.	Micro-switch ⁽¹⁾	weight kg/pce	pack.	Catalog Number
000	2	3,3	Z223674	1A613.	Y	0,12	3	NH000GG40V2
000	4	1,35	A223675	1A619.	Y	0,12	3	NH000GG40V4
000	6	1,7	B223676	1A623.	Y	0,12	3	NH000GG40V6
000	10	1,0	C223677	1A631.	Y	0,12	3	NH000GG40V10
000	16	1,8	D223678	1A635.	Y	0,12	9	NH000GG40V16
000	20	2,0	E223679	1A637.	Y	0,12	9	NH000GG40V20
000	25	2,4	F223680	1A639.	Y	0,12	9	NH000GG40V25
000	32	2,6	G223681	1A643.	Y	0,12	9	NH000GG40V32
000	35	3,2	H223682	1A645.	Y	0,12	9	NH000GG40V35
000	40	3,1	J223683	1A647.	Y	0,12	9	NH000GG40V45
000	50	3,5	K223684	1A651.	Y	0,12	9	NH000GG40V50
000	63	4,6	L223685	1A655.	Y	0,12	9	NH000GG40V63
000	80	5,0	M223686	1A659.	Y	0,12	9	NH000GG40V80
000	100	5,5	N223687	1A663.	Y	0,12	9	NH000GG40V100
00	125	8,6	E223702	1A765.	Y	0,18	3	NH00GG40V125
00	160	9,6	F223703	1A769.	Y	0,18	3	NH00GG40V160
1	35	3,9	J223706	1A145.	N	0,28	3	NH1GG40V35
1	50	4,5	K223707	1A151.	N	0,28	3	NH1GG40V50
1	63	5,7	L223708	1A155.	N	0,28	3	NH1GG40V63
1	80	5,5	M223709	1A159.	N	0,28	3	NH1GG40V80
1	100	7,0	N223710	1A163.	N	0,28	3	NH1GG40V100
1	125	9,1	P223711	1A165.	N	0,30	3	NH1GG40V125
1	160	13,0	Q223712	1A169.	Y	0,30	3	NH1GG40V160
1	200	13,1	R223713	1A171.	Y	0,30	3	NH1GG40V200
1	224	15,1	S223714	1A173.	Y	0,30	3	NH1GG40V224
1	250	16,9	T223715	1A175.	Y	0,30	3	NH1GG40V250
2	35	3,9	T227257	1A245.	N	1,87	3	NH2GG40V35
2	50	4,5	V227258	1A251.	N	1,87	3	NH2GG40V50
2	63	5,7	W227259	1A255.	N	1,87	3	NH2GG40V63
2	80	6,1	F223726	1A259.	N	0,32	3	NH2GG40V80
2	100	7,3	G223727	1A263.	N	0,32	3	NH2GG40V100
2	125	9,1	H223728	1A265.	N	0,32	3	NH2GG40V125
2	160	13,0	J223729	1A269.	N	0,32	3	NH2GG40V160
2	200	13,5	K223730	1A271.	N	0,32	3	NH2GG40V200
2	224	15,1	L223731	1A273.	N	0,32	3	NH2GG40V224
2	250	18,0	M223732	1A275.	N	0,32	3	NH2GG40V250
2	315	19,9	N223733	1A279.	Y	0,40	3	NH2GG40V315
2	355	22,7	P223734	1A281.	Y	0,40	3	NH2GG40V355
2	400	28,0	Q223735	1A283.	Y	0,40	3	NH2GG40V400
3	250	19,9	R223736	1A375.	N	0,45	1	NH3GG40V250
3	315	22,7	S223737	1A379.	N	0,45	1	NH3GG40V315
3	400	28,0	T223738	1A383.	Y	0,45	1	NH3GG40V400
3	500	30,8	V223739	1A387.	Y	0,60	1	NH3GG40V500
3	630	43,0	W223740	1A389.	Y	0,60	1	NH3GG40V630

(1) Suitable for Microswitch describes gG/aM Mechanics for Ceramic body Section page GPEU34

General Purpose IEC Fuses



NH Fuses (Plain Blades) gG 400V, 500V, 690V gG 400V Size 000 to 3 - Isolated Lug



Pb-free

NH-fuses, 400VAC gG

with isolated metal gripping lugs (SGL), double indicator, contact blades, complying with DIN VDE 0636 Part 201 and IEC 60269-2-1

Size	Rated current I_N (A)	Power dissipation (W)	FS ref.-no.	Previous ref.	weight kg/pce	pack.	Catalog Number
000	2	3,3	P223688	1E613.	0,12	3	NH000GG40V2-1
000	4	1,35	Q223689	1E619.	0,12	3	NH000GG40V4-1
000	6	1,7	R223690	1E623.	0,12	3	NH000GG40V6-1
000	10	1,0	S223691	1E631.	0,12	3	NH000GG40V10-1
000	16	1,8	T223692	1E635.	0,12	9	NH000GG40V16-1
000	20	2,0	V223693	1E637.	0,12	9	NH000GG40V20-1
000	25	2,4	W223694	1E639.	0,12	9	NH000GG40V25-1
000	32	2,6	X223695	1E643.	0,12	9	NH000GG40V32-1
000	35	3,2	Y223696	1E645.	0,12	9	NH000GG40V35-1
000	40	3,1	Z223697	1E647.	0,12	9	NH000GG40V40-1
000	50	3,5	A223698	1E651.	0,12	9	NH000GG40V50-1
000	63	4,6	B223699	1E655.	0,12	9	NH000GG40V63-1
000	80	5,0	C223700	1E659.	0,12	9	NH000GG40V80-1
000	100	5,5	D223701	1E663.	0,12	9	NH000GG40V100-1
00	125	8,6	G223704	1E765.	0,18	3	NH00GG40V125-1
00	160	9,6	H223705	1E769.	0,18	3	NH00GG40V160-1
1	35	3,9	V223716	1E145.	0,28	3	NH1GG40V35-1
1	50	4,5	W223717	1E151.	0,28	3	NH1GG40V50-1
1	63	5,7	X223718	1E155.	0,28	3	NH1GG40V63-1
1	80	5,5	Y223719	1E159.	0,28	3	NH1GG40V80-1
1	100	7,0	Z223720	1E163.	0,28	3	NH1GG40V100-1
1	125	9,1	A223721	1E165.	0,30	3	NH1GG40V125-1
1	160	13,0	B223722	1E169.	0,30	3	NH1GG40V160-1
1	200	13,1	C223723	1E171.	0,30	3	NH1GG40V200-1
1	224	15,1	D223724	1E173.	0,30	3	NH1GG40V224-1
1	250	16,9	E223725	1E175.	0,30	3	NH1GG40V250-1
2	35	3,9	L227250	1E245.	2,65	3	NH2GG40V35-1
2	50	4,5	M227251	1E251.	2,65	3	NH2GG40V50-1
2	63	5,7	N227252	1E255.	2,65	3	NH2GG40V63-1
2	80	6,1	X223741	1E259.	0,32	3	NH2GG40V80-1
2	100	7,3	Y223742	1E263.	0,32	3	NH2GG40V100-1
2	125	9,1	Z223743	1E265.	0,32	3	NH2GG40V125-1
2	160	13,0	A223744	1E269.	0,32	3	NH2GG40V160-1
2	200	13,5	B223745	1E271.	0,32	3	NH2GG40V200-1
2	224	15,1	C223746	1E273.	0,32	3	NH2GG40V224-1
2	250	18,0	D223747	1E275.	0,32	3	NH2GG40V250-1
2	315	19,9	E223748	1E279.	0,40	3	NH2GG40V315-1
2	355	22,7	F223749	1E281.	0,40	3	NH2GG40V355-1
2	400	28,0	G223750	1E283.	0,40	3	NH2GG40V400-1
3	250	19,9	H223751	1E375.	0,45	1	NH3GG40V250-1
3	315	22,7	J223752	1E379.	0,45	1	NH3GG40V315-1
3	400	28,0	K223753	1E383.	0,45	1	NH3GG40V400-1
3	500	30,8	L223754	1E387.	0,60	1	NH3GG40V500-1
3	630	43,0	M223755	1E389.	0,60	1	NH3GG40V630-1

Non suitable for Microswitch.

General Purpose IEC Fuses



Cd/Pb-free

NH Fuses (Plain Blades) gG 400V, 500V, 690V gG 500V Size 000 to 4a

NH-fuses, 500VAC gG

with non-isolated gripping lugs, double indicator, contact blades, complying with DIN VDE 0636 Part 201 and IEC 60269-2-1

Size	Rated current I_N (A)	Power dissipation (W)	FS ref.-no.	Previous ref.	Micro-switch ⁽¹⁾	weight kg/pce	pack.	Catalog Number
000	2	1,9	B211946	1B613.	Y	0,13	3	NH000GG50V2
000	4	1,5	M212462	1B619.	Y	0,13	3	NH000GG50V4
000	6	1,6	D213995	1B623.	Y	0,13	3	NH000GG50V6
000	10	1,1	B219651	1B631.	Y	0,13	3	NH000GG50V10
000	16	1,8	K222097	1B635.	Y	0,13	9	NH000GG50V16
000	20	2,3	A222847	1B637.	Y	0,13	9	NH000GG50V20
000	25	2,4	E201185	1B639.	Y	0,13	9	NH000GG50V25
000	32	3,1	Z211438	1B643.	Y	0,13	9	NH000GG50V32
000	35	3,0	C211947	1B645.	Y	0,13	9	NH000GG50V35
000	40	3,7	N212463	1B647.	Y	0,13	9	NH000GG50V40
000	50	4,1	T212974	1B651.	Y	0,13	9	NH000GG50V50
000	63	5,4	E213996	1B655.	Y	0,13	9	NH000GG50V63
000	80	6,5	Y216543	1B659.	Y	0,13	9	NH000GG50V80
000	100	7,5	B219122	1B663.	Y	0,13	9	NH000GG50V100
00	125	10,0	R201863	1B765.	Y	0,20	3	NH00GG50V125
00	160	12,3	P211084	1B769.	Y	0,20	3	NH00GG50V160
0	6	1,6	H213148	1B023.	Y	0,27	3	NH0GG50V6
0	10	1,1	G214159	1B031.	Y	0,27	3	NH0GG50V10
0	16	1,8	Q215179	1B035.	Y	0,27	3	NH0GG50V16
0	20	2,3	R215686	1B037.	Y	0,27	3	NH0GG50V20
0	25	2,4	Y216198	1B039.	Y	0,27	3	NH0GG50V25
0	32	3,1	W216702	1B043.	Y	0,27	3	NH0GG50V32
0	35	3,0	J217220	1B045.	Y	0,27	3	NH0GG50V35
0	40	3,7	P217731	1B047.	Y	0,27	3	NH0GG50V40
0	50	4,1	Z218246	1B051.	Y	0,27	3	NH0GG50V50
0	63	6,6	N218765	1B055.	Y	0,27	3	NH0GG50V63
0	80	8,0	C219284	1B059.	Y	0,27	3	NH0GG50V80
0	100	9,4	D219814	1B063.	Y	0,27	3	NH0GG50V100
0	125	11,8	P222492	1B065.	Y	0,27	3	NH0GG50V125
0	160	14,6	F223013	1B069.	Y	0,27	3	NH0GG50V160
0	200	18,1	C229611	1B071.	Y	0,27	3	NH0GG50V200
0	224	19,2	D229612	1B073.	Y	0,27	3	NH0GG50V224
0	250	20,3	E229613	1B075.	Y	0,27	3	NH0GG50V250
1	16	1,8	M200801	1B135.	N	0,28	3	NH1GG50V16
1	20	2,3	C201344	1B137.	N	0,28	3	NH1GG50V20
1	25	2,4	N201860	1B139.	N	0,28	3	NH1GG50V25
1	32	3,1	L211081	1B143.	N	0,28	3	NH1GG50V32
1	35	3,0	A211600	1B145.	N	0,28	3	NH1GG50V35
1	40	3,7	Y212633	1B147.	N	0,28	3	NH1GG50V40
1	50	4,1	B213648	1B151.	N	0,28	3	NH1GG50V50
1	63	6,6	L214669	1B155.	N	0,28	3	NH1GG50V63
1	80	8,0	S215687	1B159.	N	0,28	3	NH1GG50V80
1	100	9,4	X216703	1B163.	N	0,28	3	NH1GG50V100
1	125	11,8	Q217732	1B165.	Y	0,30	3	NH1GG50V125
1	160	14,6	A218247	1B169.	Y	0,30	3	NH1GG50V160
1	200	18,0	P218766	1B171.	Y	0,30	3	NH1GG50V200
1	224	19,0	D219285	1B173.	Y	0,30	3	NH1GG50V224
1	250	20,0	E219815	1B175.	Y	0,30	3	NH1GG50V250
1	315	20,5	Q228519	1B179.	Y	0,42	3	NH1GG50V315
1	355	23,7	R228520	1B181.	Y	0,42	3	NH1GG50V355

(1) Suitable for Microswitch describes page 106

General Purpose IEC Fuses



NH Fuses (Plain Blades) gG 400V, 500V, 690V gG 500V Size 000 to 4a



NH-fuses, 500VAC gG

with non-isolated gripping lugs, double indicator, contact blades, complying with DIN VDE 0636 Part 201 and IEC 60269-2-1

Cd/Pb-free

Size	Rated current I_N (A)	Power dissipation (W)	FS ref.-no.	Previous ref.	Micro-switch ⁽¹⁾	weight kg/pce	pack.	Catalog Number
2	25	2,4	N200802	1B239.	N	0,42	3	NH2GG50V25
2	32	3,1	D201345	1B243.	N	0,42	3	NH2GG50V32
2	35	3,0	P201861	1B245.	N	0,42	3	NH2GG50V35
2	40	3,7	M211082	1B247.	N	0,42	3	NH2GG50V40
2	50	4,1	B211601	1B251.	N	0,42	3	NH2GG50V50
2	63	6,8	Z212634	1B255.	N	0,42	3	NH2GG50V63
2	80	8,3	C213649	1B259.	N	0,42	3	NH2GG50V80
2	100	10,7	M214670	1B263.	N	0,42	3	NH2GG50V100
2	125	12,2	T215688	1B265.	N	0,42	3	NH2GG50V125
2	160	15,0	Y216704	1B269.	N	0,42	3	NH2GG50V160
2	200	18,5	R217733	1B271.	N	0,42	3	NH2GG50V200
2	224	19,2	Q218767	1B273.	N	0,42	3	NH2GG50V224
2	250	20,6	R222494	1B275.	N	0,42	3	NH2GG50V250
2	300	21,0	P200803	1B277.	Y	0,64	3	NH2GG50V300
2	315	25,0	E201346	1B279.	Y	0,64	3	NH2GG50V315
2	355	31,5	Q201862	1B281.	Y	0,64	3	NH2GG50V355
2	400	28,5	N211083	1B283.	Y	0,64	3	NH2GG50V400
2	425	29,2	S228521	1B285.	Y	0,64	3	NH2GG50V425
2	500	35,6	T228522	1B287.	Y	0,64	3	NH2GG50V500
3	250	21,1	C211602	1B375.	N	0,65	1	NH3GG50V250
3	300	20,0	A212635	1B377.	N	0,65	1	NH3GG50V300
3	315	25,0	L213151	1B379.	N	0,65	1	NH3GG50V315
3	355	32,0	K214162	1B381.	N	0,65	1	NH3GG50V355
3	400	34,0	T215182	1B383.	N	1,05	1	NH3GG50V400
3	425	34,0	B216201	1B385.	Y	1,05	1	NH3GG50V425
3	450	38,0	Z216705	1B386.	Y	1,05	1	NH3GG50V450
3	500	43,0	M217223	1B387.	Y	1,05	1	NH3GG50V500
3	630	43,1	S217734	1B389.	Y	1,05	1	NH3GG50V630
3	800	53,2	V228523	1B391.	Y	1,05	1	NH3GG50V800

with screw contact

4	400	31,0	*)	A216039	8004.4007	N	2,00	1	NH4GG50V400-8
4	500	35,0	*)	X216542	8004.5007	N	2,00	1	NH4GG50V500-8
4	630	46,6	*)	W217576	8004.6307	N	2,00	1	NH4GG50V630-8
4	800	70,0	*)	E218090	8004.8007	N	2,00	1	NH4GG50V800-8
4	1000	83,3	*)	H201694	8004.1007	N	2,00	1	NH4GG50V1000-8
4	1250	110,0	*)	C213994	8004.1257	N	2,00	1	NH4GG50V1250-8

contact blades for NH-bottom size 4a with swivel unit

4a	500	35,0	*)	D201184	8014.5007	N	1,95	1	NH4AGG50V500-8
4a	630	46,6	*)	T205752	8014.6307	N	1,95	1	NH4AGG50V630-8
4a	800	70,0	*)	Y211437	8014.8007	N	1,95	1	NH4AGG50V800-8
4a	1000	83,3	*)	A219650	8014.1007	N	1,95	1	NH4AGG50V1000-8
4a	1250	110,0	*)	J200637	8014.1257	N	1,95	1	NH4AGG50V1250-8

*) with indicator on top

(1) Suitable for Microswitch describes page 106

General Purpose IEC Fuses



Cd/Pb-free

NH Fuses (Plain Blades) gG 400V, 500V, 690V gG 500V Size 000 to 3 - Isolated Lug

NH-fuses, 500VAC gG

with isolated metal gripping lugs (SGL), double indicator, contact blades, complying with DIN VDE 0636 Part 201 and IEC 60269-2-1

Size	Rated current I_N (A)	Power dissipation (W)	FS ref.-no.	Previous ref.	weight kg/pce	pack.	Catalog Number
000	2	1,9	C219652	1F613.	0,14	3	NH000GG50V2-1
000	4	1,5	N205770	1F619.	0,14	3	NH000GG50V4-1
000	6	1,6	P212464	1F623.	0,14	3	NH000GG50V6-1
000	10	1,1	V215528	1F631.	0,14	3	NH000GG50V10-1
000	16	1,8	F213997	1F635.	0,14	9	NH000GG50V16-1
000	20	2,3	F218091	1F637.	0,14	9	NH000GG50V20-1
000	25	2,4	K200638	1F639.	0,14	9	NH000GG50V25-1
000	32	3,1	D213489	1F643.	0,14	9	NH000GG50V32-1
000	35	3,0	G201187	1F645.	0,14	9	NH000GG50V35-1
000	40	3,7	D219653	1F647.	0,14	9	NH000GG50V40-1
000	50	4,1	C222849	1F651.	0,14	9	NH000GG50V50-1
000	63	5,4	R212466	1F655.	0,14	9	NH000GG50V63-1
000	80	6,5	N215016	1F659.	0,14	9	NH000GG50V80-1
000	100	7,5	J201189	1F663.	0,14	9	NH000GG50V100-1
00	125	10,0	V200808	1F765.	0,20	3	NH00GG50V125-1
00	160	12,3	W201867	1F769.	0,20	3	NH00GG50V160-1
0	6	1,6	B212636	1F023.	0,26	3	NH0GG50V6-1
0	10	1,1	M213152	1F031.	0,26	3	NH0GG50V10-1
0	16	1,8	E213651	1F035.	0,26	3	NH0GG50V16-1
0	20	2,3	L214163	1F037.	0,26	3	NH0GG50V20-1
0	25	2,4	P214672	1F039.	0,26	3	NH0GG50V25-1
0	32	3,1	V215183	1F043.	0,26	3	NH0GG50V32-1
0	35	3,0	W215690	1F045.	0,26	3	NH0GG50V35-1
0	40	3,7	C216202	1F047.	0,26	3	NH0GG50V40-1
0	50	4,1	A216706	1F051.	0,26	3	NH0GG50V50-1
0	63	6,6	N217224	1F055.	0,26	3	NH0GG50V63-1
0	80	8,0	T217735	1F059.	0,26	3	NH0GG50V80-1
0	100	9,4	D218250	1F063.	0,26	3	NH0GG50V100-1
0	125	11,8	S218769	1F065.	0,26	3	NH0GG50V125-1
0	160	14,6	F219287	1F069.	0,26	3	NH0GG50V160-1
1	16	1,8	H219818	1F135.	0,29	3	NH1GG50V16-1
1	20	2,3	T222496	1F137.	0,29	3	NH1GG50V20-1
1	25	2,4	K223017	1F139.	0,29	3	NH1GG50V25-1
1	32	3,1	R200805	1F143.	0,29	3	NH1GG50V32-1
1	35	3,0	G201348	1F145.	0,29	3	NH1GG50V35-1
1	40	3,7	Q211085	1F147.	0,29	3	NH1GG50V40-1
1	50	4,1	L212116	1F151.	0,29	3	NH1GG50V50-1
1	63	6,6	N213153	1F155.	0,29	3	NH1GG50V63-1
1	80	8,0	M214164	1F159.	0,29	3	NH1GG50V80-1
1	100	9,4	W215184	1F163.	0,29	3	NH1GG50V100-1
1	125	11,8	D216203	1F165.	0,42	3	NH1GG50V125-1
1	160	14,6	B216707	1F169.	0,42	3	NH1GG50V160-1
1	200	18,0	P217225	1F171.	0,42	3	NH1GG50V200-1
1	224	19,0	V217736	1F173.	0,42	3	NH1GG50V224-1
1	250	20,0	E218251	1F175.	0,42	3	NH1GG50V250-1

Non suitable for Microswitch.

General Purpose IEC Fuses



NH Fuses (Plain Blades) gG 400V, 500V, 690V gG 500V Size 000 to 3 - Isolated Lug



Cd/Pb-free

NH-fuses, 500VAC gG

with isolated metal gripping lugs (SGL), double indicator, contact blades, complying with DIN VDE 0636 Part 201 and IEC 60269-2-1

Size	Rated current I_N (A)	Power dissipation (W)	FS ref.-no.	Previous ref.	weight kg/pce	pack.	Catalog Number
2	25	2,4	J219819	1F239.	0,42	3	NH2GG50V25-1
2	32	3,1	V222497	1F243.	0,42	3	NH2GG50V32-1
2	35	3,0	L223018	1F245.	0,42	3	NH2GG50V35-1
2	40	3,7	S200806	1F247.	0,42	3	NH2GG50V40-1
2	50	4,1	H201349	1F251.	0,42	3	NH2GG50V50-1
2	63	6,8	T201865	1F255.	0,42	3	NH2GG50V63-1
2	80	8,3	F211605	1F259.	0,42	3	NH2GG50V80-1
2	100	10,7	P213154	1F263.	0,42	3	NH2GG50V100-1
2	125	12,2	N214165	1F265.	0,42	3	NH2GG50V125-1
2	160	15,0	X215185	1F269.	0,42	3	NH2GG50V160-1
2	200	18,5	E216204	1F271.	0,42	3	NH2GG50V200-1
2	224	19,2	Q217226	1F273.	0,42	3	NH2GG50V224-1
2	250	20,6	F218252	1F275.	0,42	3	NH2GG50V250-1
2	300	21,0	H219289	1F277.	0,64	3	NH2GG50V300-1
2	315	25,0	K219820	1F279.	0,64	3	NH2GG50V315-1
2	355	31,5	M223019	1F281.	0,64	3	NH2GG50V355-1
2	400	28,5	T200807	1F283.	0,64	3	NH2GG50V400-1
3	250	21,1	J201350	1F375.	0,65	1	NH3GG50V250-1
3	300	20,0	S211087	1F377.	0,65	1	NH3GG50V300-1
3	315	25,0	G211606	1F379.	0,65	1	NH3GG50V315-1
3	355	32,0	E212639	1F381.	0,65	1	NH3GG50V355-1
3	400	34,0	H213654	1F383.	1,05	1	NH3GG50V400-1
3	425	34,0	S214675	1F385.	1,05	1	NH3GG50V425-1
3	450	38,0	Z215693	1F386.	1,05	1	NH3GG50V450-1
3	500	43,0	F216205	1F387.	1,05	1	NH3GG50V500-1
3	630	43,1	D216709	1F389.	1,05	1	NH3GG50V630-1

Non suitable for Microswitch.

General Purpose IEC Fuses

NH Fuses (Plain Blades) gG 400V, 500V, 690V gG 690V Size 000 to 4a



Cd/Pb-free

with non-isolated gripping lugs, double indicator, contact blades, complying with DIN VDE 0636 Part 201 and IEC 60269-2-1

NH-fuses, 690VAC gG

Size	Rated current I_N (A)	Power dissipation (W)	FS ref.-no.	Previous ref.	Micro-switch ⁽¹⁾	weight kg/pce	pack.	Catalog Number
000	2	1,9	E228440	1C613.	Y	0,13	3	NH000GG69V2
000	4	1,5	F228441	1C619.	Y	0,13	3	NH000GG69V4
000	6	1,6	G228442	1C623.	Y	0,13	3	NH000GG69V6
000	10	1,1	J228444	1C631.	Y	0,13	3	NH000GG69V10
000	16	1,8	K228445	1C635.	Y	0,13	3	NH000GG69V16
000	20	2,3	L228446	1C637.	Y	0,13	3	NH000GG69V20
000	25	2,4	M228447	1C639.	Y	0,13	3	NH000GG69V25
000	32	3,1	N228448	1C643.	Y	0,13	3	NH000GG69V32
000	35	3,0	P228449	1C645.	Y	0,13	3	NH000GG69V35
000	40	3,7	Q228450	1C647.	Y	0,13	3	NH000GG69V40
000	50	4,1	R228451	1C651.	Y	0,13	3	NH000GG69V50
000	63	5,4	S228452	1C655.	Y	0,13	3	NH000GG69V63
000	80	6,5	T228453	1C659.	Y	0,13	3	NH000GG69V80
00	32	3,1	V228454	1C743.	Y	0,20	3	NH00GG69V32
00	35	3,0	W228455	1C745.	Y	0,20	3	NH00GG69V35
00	40	3,7	X228456	1C747.	Y	0,20	3	NH00GG69V40
00	50	4,1	Y228457	1C751.	Y	0,20	3	NH00GG69V50
00	63	5,6	Z228458	1C755.	Y	0,20	3	NH00GG69V63
00	80	6,8	A228459	1C759.	Y	0,20	3	NH00GG69V80
00	100	7,5	B228460	1C763.	Y	0,20	3	NH00GG69V100
00	125	10,0	C228461	1C765.	Y	0,20	3	NH00GG69V125
0	6	1,6	D228462	1C023.	Y	0,27	3	NH0GG69V6
0	10	1,1	E228463	1C031.	Y	0,27	3	NH0GG69V10
0	16	1,8	F228464	1C035.	Y	0,27	3	NH0GG69V16
0	20	2,3	G228465	1C037.	Y	0,27	3	NH0GG69V20
0	25	2,4	H228466	1C039.	Y	0,27	3	NH0GG69V25
0	32	3,1	J228467	1C043.	Y	0,27	3	NH0GG69V32
0	35	3,0	K228468	1C045.	Y	0,27	3	NH0GG69V35
0	40	3,7	L228469	1C047.	Y	0,27	3	NH0GG69V40
0	50	4,1	M228470	1C051.	Y	0,27	3	NH0GG69V50
0	63	6,6	N228471	1C055.	Y	0,27	3	NH0GG69V63
0	80	8,0	P228472	1C059.	Y	0,27	3	NH0GG69V80
0	100	9,4	Q228473	1C063.	Y	0,27	3	NH0GG69V100
0	125	11,8	R228474	1C065.	Y	0,27	3	NH0GG69V125
0	160	14,6	S228475	1C069.	Y	0,27	3	NH0GG69V160
1	16	1,8	T228476	1C135.	N	0,26	3	NH1GG69V16
1	20	2,3	V228477	1C137.	N	0,26	3	NH1GG69V20
1	25	2,4	W228478	1C139.	N	0,26	3	NH1GG69V25
1	32	3,1	X228479	1C143.	N	0,26	3	NH1GG69V32
1	35	3,0	Y228480	1C145.	N	0,26	3	NH1GG69V35
1	40	3,7	Z228481	1C147.	N	0,26	3	NH1GG69V40
1	50	4,1	A228482	1C151.	N	0,26	3	NH1GG69V50
1	63	6,6	B228483	1C155.	N	0,26	3	NH1GG69V63
1	80	8,0	C228484	1C159.	N	0,26	3	NH1GG69V80
1	100	9,4	D228485	1C163.	N	0,26	3	NH1GG69V100
1	125	11,8	E228486	1C165.	N	0,42	3	NH1GG69V125
1	160	14,6	F228487	1C169.	N	0,42	3	NH1GG69V160
1	200	18,0	G228488	1C171.	Y	0,42	3	NH1GG69V200
1	224	19,0	V233261	1C173.	Y	0,42	3	NH1GG69V224
1	250	20,0	W233262	1C175.	Y	0,42	3	NH1GG69V250

(1) Suitable for Microswitch describes page 106

General Purpose IEC Fuses



NH Fuses (Plain Blades) gG 400V, 500V, 690V gG 690V Size 000 to 4a



NH-fuses, 690VAC gG

with non-isolated gripping lugs, double indicator, contact blades, complying with DIN VDE 0636 Part 201 and IEC 60269-2-1

Cd/Pb-free

Size	Rated current I_N (A)	Power dissipation (W)	FS ref.-no.	Previous ref.	Micro-switch ⁽¹⁾	weight kg/pce	pack.	Catalog Number
2	32	3,1	H228489	1C243.	N	0,42	3	NH2GG69V32
2	35	3,0	J228490	1C245.	N	0,42	3	NH2GG69V35
2	40	3,7	K228491	1C247.	N	0,42	3	NH2GG69V40
2	50	4,1	L228492	1C251.	N	0,42	3	NH2GG69V50
2	63	6,8	M228493	1C255.	N	0,42	3	NH2GG69V63
2	80	8,3	N228494	1C259.	N	0,42	3	NH2GG69V80
2	100	10,7	P228495	1C263.	N	0,42	3	NH2GG69V100
2	125	12,2	Q228496	1C265.	Y	0,42	3	NH2GG69V125
2	160	15,0	R228497	1C269.	Y	0,42	3	NH2GG69V160
2	200	18,5	S228498	1C271.	Y	0,42	3	NH2GG69V200
2	224	19,2	T228499	1C273.	Y	0,42	3	NH2GG69V224
2	250	20,6	V228500	1C275.	Y	0,42	3	NH2GG69V250
2	300	21,0	W228501	1C277.	Y	0,64	3	NH2GG69V300
2	315	25,0	X228502	1C279.	Y	0,65	3	NH2GG69V315
2	355	31,5	Y228503	1C281.	Y	0,65	3	NH2GG69V355
3	250	21,1	Z228504	1C375.	N	0,65	1	NH3GG69V250
3	300	22,6	A228505	1C377.	N	0,65	1	NH3GG69V300
3	315	25,0	B228506	1C379.	Y	0,65	1	NH3GG69V315
3	355	32,0	C228507	1C381.	Y	0,65	1	NH3GG69V355
3	400	34,0	D228508	1C383.	Y	1,05	1	NH3GG69V400
3	425	34,0	E228509	1C385.	Y	1,05	1	NH3GG69V425
3	500	43,0	F228510	1C387.	Y	1,05	1	NH3GG69V500

with screw contact

4	400	31,0	*)	N214004	8004.400765	N	2,00	1	NH4GG69V400-8
4	500	35,0	*)	Y215025	8004.500765	N	2,00	1	NH4GG69V500-8
4	630	46,6	*)	E215537	8004.630765	N	2,00	1	NH4GG69V630-8
4	800	70,0	*)	K216554	8004.800765	N	2,00	1	NH4GG69V800-8

contact blades for NH-bottom size 4a with swivel unit

4a	400	31,0	*)	W217070	8014.400765	N	1,95	1	NH4AGG69V400-8
4a	500	35,0	*)	H217587	8014.500765	N	1,95	1	NH4AGG69V500-8
4a	630	46,6	*)	W222107	8014.630765	N	1,95	1	NH4AGG69V630-8
4a	800	70,0	*)	M222858	8014.800765	N	1,95	1	NH4AGG69V800-8

*) with indicator on top

(1) Suitable for Microswitch describes page 106

General Purpose IEC Fuses



Cd/Pb-free

NH Fuses (Plain Blades) gG 400V, 500V, 690V gG 690V Size 000 to 3 - Isolated Lug

NH-fuses, 690VAC gG

with isolated metal gripping lugs (SGL), double indicator, contact blades, complying with DIN VDE 0636 Part 201 and IEC 60269-2-1

Size	Rated current I _N (A)	Power dissipation (W)	FS ref.-no.	Previous ref.	weight kg/pce	pack.	Catalog Number
000	2	1,9	D229704	1G613.	0,14	3	NH000GG69V2-1
000	4	1,5	E229705	1G619.	0,14	3	NH000GG69V4-1
000	6	1,6	F229706	1G623.	0,14	3	NH000GG69V6-1
000	10	1,1	H229708	1G631.	0,14	3	NH000GG69V10-1
000	16	1,8	J229709	1G635.	0,14	3	NH000GG69V16-1
000	20	2,3	K229710	1G637.	0,14	3	NH000GG69V20-1
000	25	2,4	L229711	1G639.	0,14	3	NH000GG69V25-1
000	32	3,1	M229712	1G643.	0,14	3	NH000GG69V32-1
000	35	3,0	N229713	1G645.	0,14	3	NH000GG69V35-1
000	40	3,7	P229714	1G647.	0,14	3	NH000GG69V40-1
000	50	4,1	Q229715	1G651.	0,14	3	NH000GG69V50-1
000	63	5,4	R229716	1G655.	0,14	3	NH000GG69V63-1
000	80	6,5	S229717	1G659.	0,14	3	NH000GG69V80-1
00	32	3,1	T229718	1G743.	0,20	3	NH00GG69V32-1
00	35	3,0	V229719	1G745.	0,20	3	NH00GG69V35-1
00	40	3,7	W229720	1G747.	0,20	3	NH00GG69V40-1
00	50	4,1	X229721	1G751.	0,20	3	NH00GG69V50-1
00	63	5,6	Y229722	1G755.	0,20	3	NH00GG69V63-1
00	80	6,8	Z229723	1G759.	0,20	3	NH00GG69V80-1
00	100	7,5	A229724	1G763.	0,20	3	NH00GG69V100-1
00	125	10,0	B229725	1G765.	0,20	3	NH00GG69V125-1
0	6	1,6	C229726	1G023.	0,26	3	NH0GG69V6-1
0	10	1,1	D229727	1G031.	0,26	3	NH0GG69V10-1
0	16	1,8	E229728	1G035.	0,26	3	NH0GG69V16-1
0	20	2,3	F229729	1G037.	0,26	3	NH0GG69V20-1
0	25	2,4	G229730	1G039.	0,26	3	NH0GG69V25-1
0	32	3,1	H229731	1G043.	0,26	3	NH0GG69V32-1
0	35	3,0	J229732	1G045.	0,26	3	NH0GG69V35-1
0	40	3,7	K229733	1G047.	0,26	3	NH0GG69V40-1
0	50	4,1	L229734	1G051.	0,26	3	NH0GG69V50-1
0	63	6,6	M229735	1G055.	0,26	3	NH0GG69V63-1
0	80	8,0	N229736	1G059.	0,26	3	NH0GG69V80-1
0	100	9,4	P229737	1G063.	0,26	3	NH0GG69V100-1
0	125	11,8	Q229738	1G065.	0,26	3	NH0GG69V125-1
0	160	14,6	R229739	1G069.	0,26	3	NH0GG69V160-1
1	16	1,8	S229740	1G135.	0,29	1	NH1GG69V16-1
1	20	2,3	T229741	1G137.	0,29	1	NH1GG69V20-1
1	25	2,4	V229742	1G139.	0,29	1	NH1GG69V25-1
1	32	3,1	W229743	1G143.	0,29	1	NH1GG69V32-1
1	35	3,0	X229744	1G145.	0,29	1	NH1GG69V35-1
1	40	3,7	Y229745	1G147.	0,29	1	NH1GG69V40-1
1	50	4,1	Z229746	1G151.	0,29	1	NH1GG69V50-1
1	63	6,6	A229747	1G155.	0,29	1	NH1GG69V63-1
1	80	8,0	B229748	1G159.	0,29	1	NH1GG69V80-1
1	100	9,4	C229749	1G163.	0,29	1	NH1GG69V100-1
1	125	11,8	D229750	1G165.	0,42	1	NH1GG69V125-1
1	160	14,6	E229751	1G169.	0,42	1	NH1GG69V160-1
1	200	18,0	F229752	1G171.	0,42	1	NH1GG69V200-1
1	224	19,0	G229753	1G173.	0,42	1	NH1GG69V224-1
2	32	3,1	J229755	1G243.	0,43	1	NH2GG69V32-1
2	35	3,0	K229756	1G245.	0,43	1	NH2GG69V35-1
2	40	3,7	L229757	1G247.	0,43	1	NH2GG69V40-1
2	50	4,1	M229758	1G251.	0,43	1	NH2GG69V50-1
2	63	6,8	N229759	1G255.	0,43	1	NH2GG69V63-1
2	80	8,3	P229760	1G259.	0,43	1	NH2GG69V80-1
2	100	10,7	Q229761	1G263.	0,43	1	NH2GG69V100-1
2	125	12,2	R229762	1G265.	0,43	1	NH2GG69V125-1
2	160	15,0	S229763	1G269.	0,43	1	NH2GG69V160-1
2	200	18,5	T229764	1G271.	0,43	1	NH2GG69V200-1
2	224	19,2	V229765	1G273.	0,43	1	NH2GG69V224-1
2	250	20,6	D233729	1G275.	0,43	1	NH2GG69V250-1
2	300	21,0	X229767	1G277.	0,43	1	NH2GG69V300-1
2	315	25,0	Y229768	1G279.	0,65	1	NH2GG69V315-1
2	355	31,5	Z229769	1G281.	0,65	1	NH2GG69V355-1
3	250	21,1	A229770	1G375.	0,65	1	NH3GG69V250-1
3	300	22,6	B229771	1G377.	1,01	1	NH3GG69V300-1
3	315	25,0	C229772	1G379.	1,01	1	NH3GG69V315-1
3	355	32,0	D229773	1G381.	1,01	1	NH3GG69V355-1
3	400	34,0	E229774	1G383.	1,01	1	NH3GG69V400-1
3	425	34,0	F229775	1G385.	1,01	1	NH3GG69V425-1

Non suitable for Microswitch.

General Purpose IEC Fuses



NH Fuses (Plain Blades) gG 400V, 500V, 690V gG Curves Set

NH-fuses, 400VAC, 500VAC gG

Total Clearing I²t

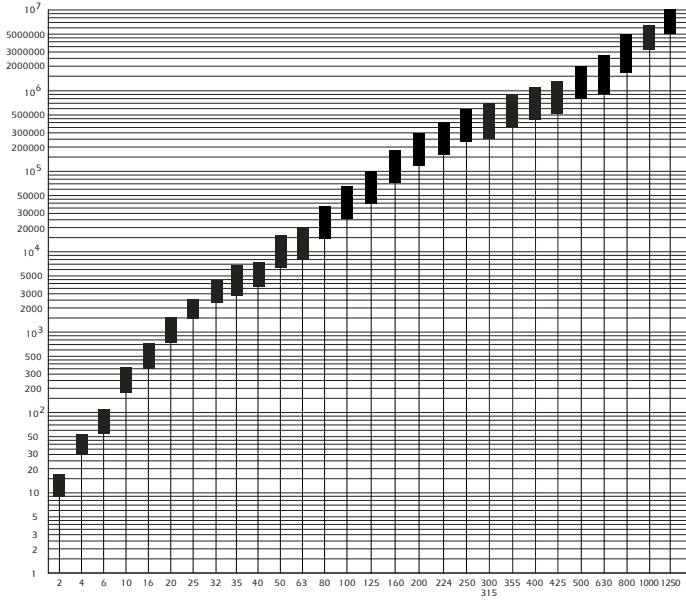

Current Limitation Curves

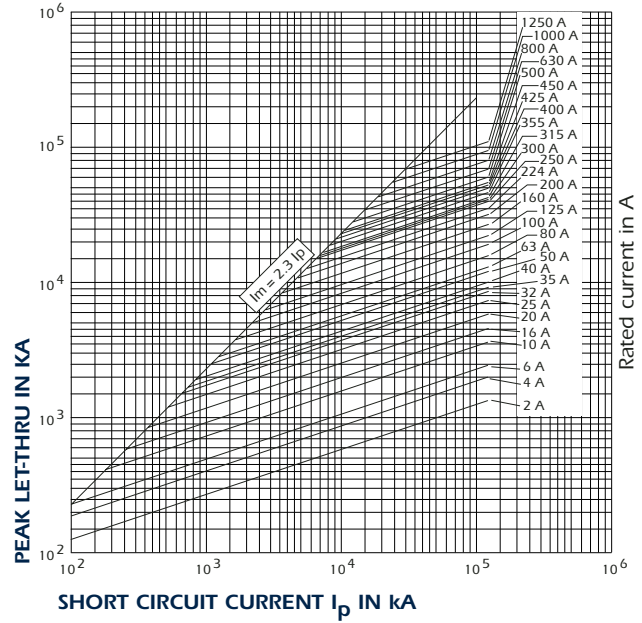

Time VS. Current Characteristics

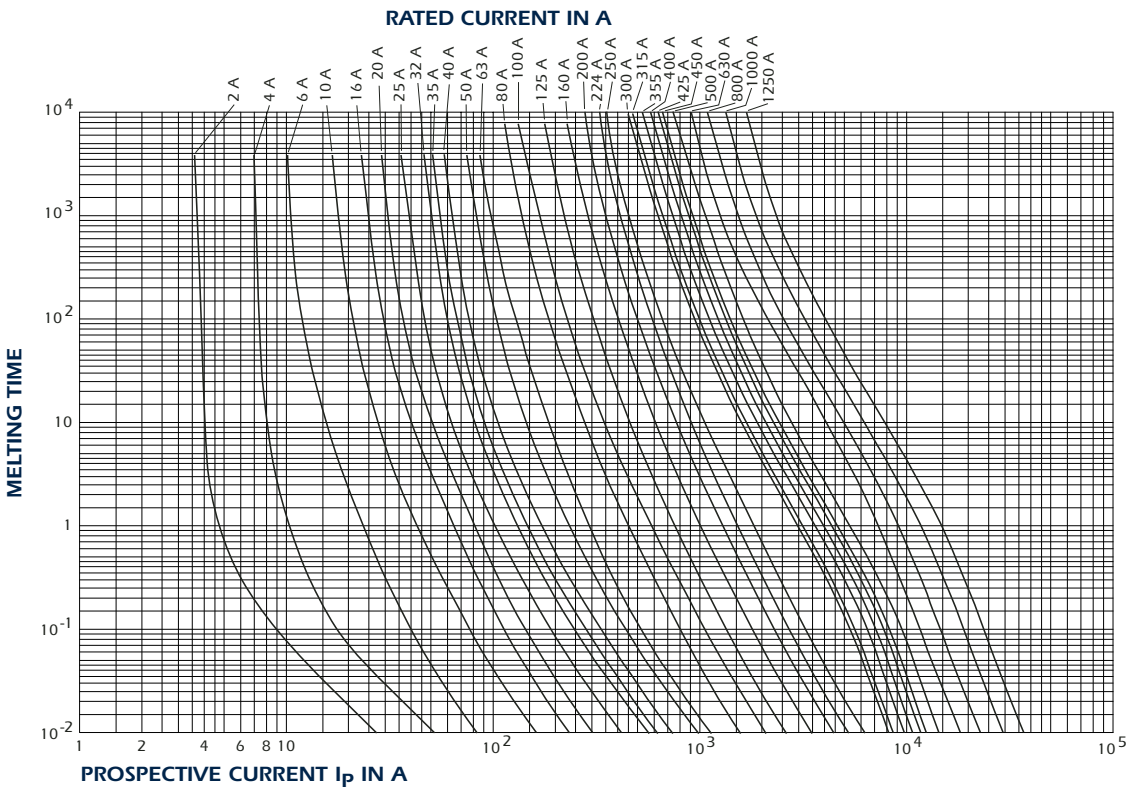

General Purpose IEC Fuses

NH Fuses (Plain Blades)
gG 400V, 500V, 690V
gG Curves Set



NH-fuses, 690VAC gG

Total Clearing I²t

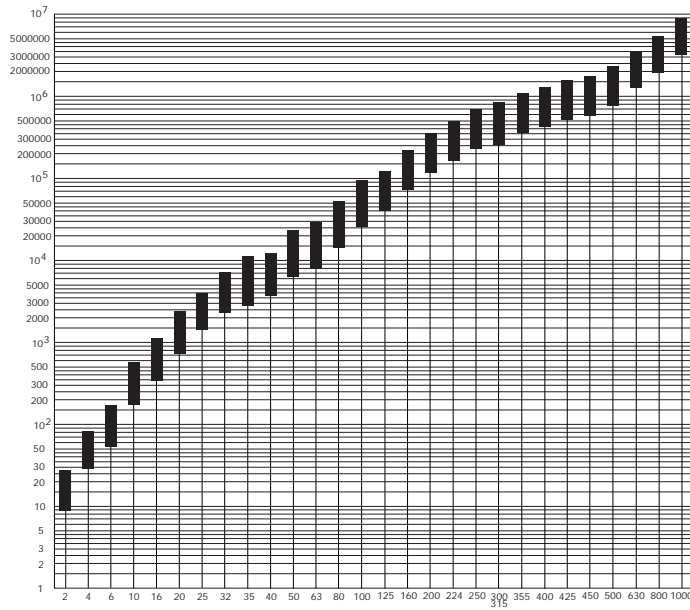

Current Limitation Curves

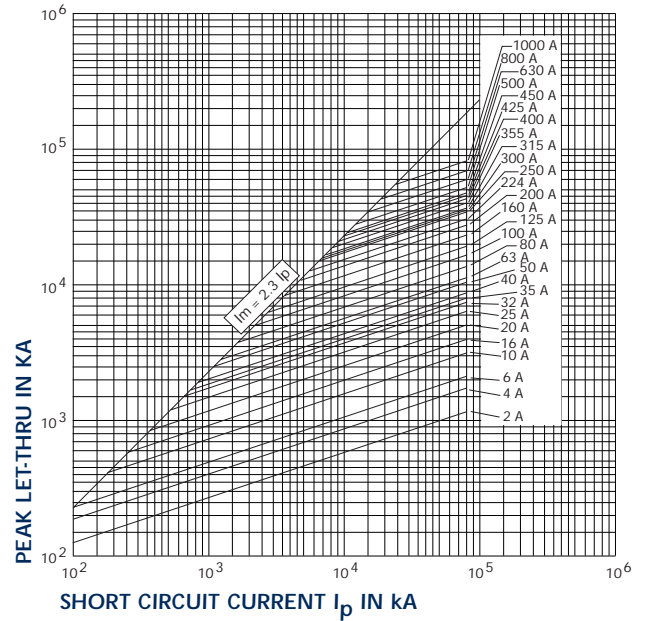

Time VS. Current

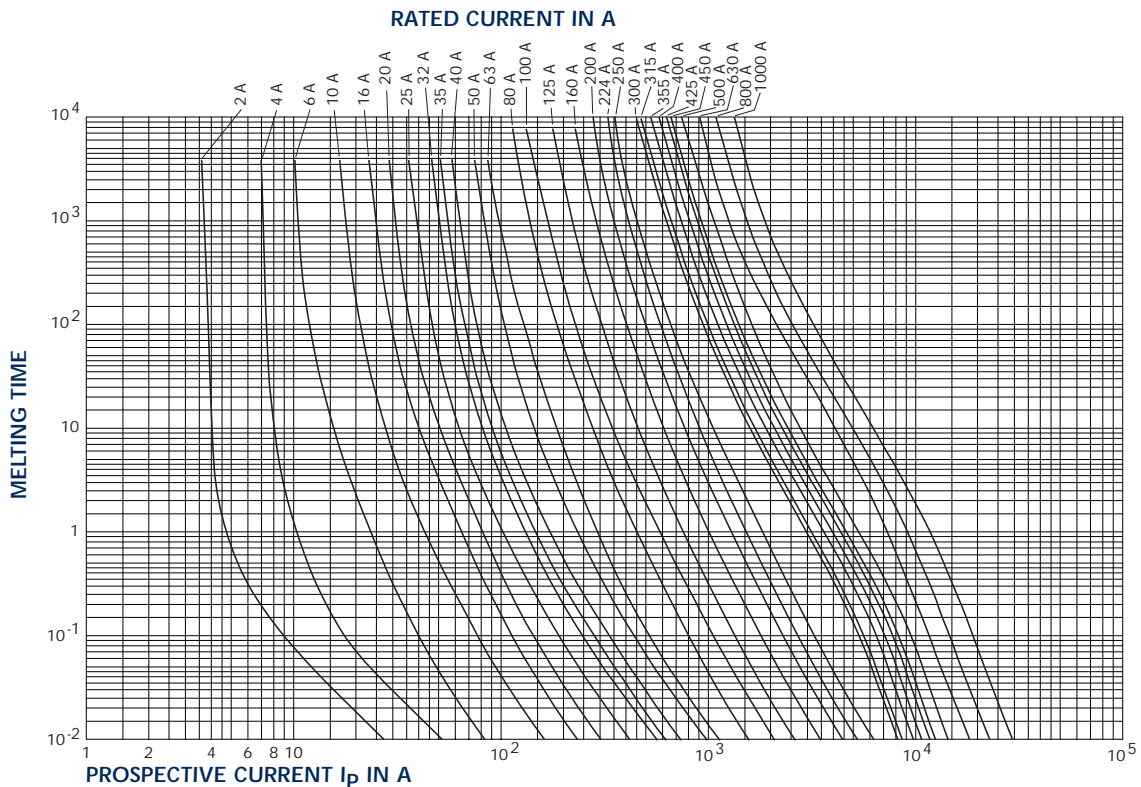

General Purpose IEC Fuses



NH Fuses (Plain Blades) aM 500V, 690V aM 500V Size 000 to 4a



Cd/Pb-free

NH-fuses, 500VAC aM

with non-isolated gripping lugs, double indicator, contact blades, complying with DIN VDE 0636 Part 201 and IEC 60269-2-1

Size	Rated current I _N (A)	Power dissipation (W)	FS ref.-no.	Previous ref.	Micro- switch ⁽¹⁾	weight kg/pce	pack.	Catalog Number
000	2	0,1	K232493	2B613.	Y	0,13	3	NH000AM50V2
000	4	0,2	L232494	2B619.	Y	0,13	3	NH000AM50V4
000	6	0,3	M232495	2B623.	Y	0,13	3	NH000AM50V6
000	10	0,5	N232496	2B631.	Y	0,13	3	NH000AM50V10
000	16	0,7	P232497	2B635.	Y	0,13	3	NH000AM50V16
000	20	0,9	Q232498	2B637.	Y	0,13	3	NH000AM50V20
000	25	1,2	R232499	2B639.	Y	0,13	3	NH000AM50V25
000	32	1,5	S232500	2B643.	Y	0,13	3	NH000AM50V32
000	35	1,6	T232501	2B645.	Y	0,13	3	NH000AM50V35
000	40	1,8	V232502	2B647.	Y	0,13	3	NH000AM50V40
000	50	2,3	W232503	2B651.	Y	0,13	3	NH000AM50V50
000	63	2,9	X232504	2B655.	Y	0,13	3	NH000AM50V63
000	80	3,6	C227863	2B659.	Y	0,13	3	NH000AM50V80
00	100	5,8	Y232505	2B763.	Y	0,20	3	NH00AM50V100
00	125	6,4	Z232506	2B765.	Y	0,20	3	NH00AM50V125
00	160	7,9	J227869	2B769.	Y	0,20	3	NH00AM50V160
0	100	6,0	A232507	2B063.	Y	0,26	3	NH0AM50V100
0	125	7,9	B232508	2B065.	Y	0,26	3	NH0AM50V125
0	160	10,5	C232509	2B069.	Y	0,26	3	NH0AM50V160
0	200	11,8	A227884	2B071.	Y	0,26	3	NH0AM50V200
1	100	5,8	D232510	2B163.	Y	0,42	3	NH1AM50V100
1	125	7,5	E232511	2B165.	Y	0,42	3	NH1AM50V125
1	160	10,4	F232512	2B169.	Y	0,42	3	NH1AM50V160
1	200	14,2	G232513	2B171.	Y	0,42	3	NH1AM50V200
1	224	15,8	H232514	2B173.	Y	0,42	3	NH1AM50V224
1	250	17,5	J232515	2B175.	Y	0,42	3	NH1AM50V250
1	315	22,1	K227962	2B179.	Y	0,42	3	NH1AM50V315
2	250	16,8	K232516	2B275.	Y	0,64	3	NH2AM50V250
2	315	23,1	L232517	2B279.	Y	0,64	3	NH2AM50V315
2	355	26,4	M232518	2B281.	Y	0,64	3	NH2AM50V355
2	400	29,7	N232519	2B283.	Y	0,64	3	NH2AM50V400
2	500	34,4	C227978	2B287.	Y	0,64	3	NH2AM50V500
3	315	21,0	P232520	2B379.	Y	1,05	1	NH3AM50V315
3	355	23,3	Q232521	2B381.	Y	1,05	1	NH3AM50V355
3	400	29,1	R232522	2B383.	Y	1,05	1	NH3AM50V400
3	425	29,1	S232523	2B385.	Y	1,05	1	NH3AM50V425
3	450	34,0	T232524	2B386.	Y	1,05	1	NH3AM50V450
3	500	42,0	V232525	2B387.	Y	1,05	1	NH3AM50V500
3	630	42,0	M227987	2B389.	Y	1,05	1	NH3AM50V630
with screw contact								
4	400	26,0	P233555	8004.400505	N	2,18	1	NH4AM50V400-8
4	500	38,0	Q233556	8004.500505	N	2,18	1	NH4AM50V500-8
4	630	50,0	E222115	8004.630505	N	2,18	1	NH4AM50V630-8
4	800	65,0	V222865	8004.800505	N	2,18	1	NH4AM50V800-8
4	1000	80,0	S219137	8004.100505	N	2,18	1	NH4AM50V1000-8
4	1250	110,0	V219668	8004.125505	N	2,21	1	NH4AM50V1250-8
contact blades for NH-bottom size 4a with swivel unit								
4a	500	38,0	R233557	8014.500505	N	2,00	1	NH4AAM50V500-8
4a	630	50,0	S233558	8014.630505	N	2,00	1	NH4AAM50V630-8
4a	800	65,0	T233559	8014.800505	N	2,00	1	NH4AAM50V800-8
4a	1000	80,0	V233560	8014.100505	N	2,00	1	NH4AAM50V1000-8
4a	1250	110,0	W233561	8014.125505	N	2,00	1	NH4AAM50V1250-8

*) with indicator on top

(1) Suitable for Microswitch describes page 106

General Purpose IEC Fuses

NH Fuses (Plain Blades) aM 500V, 690V aM 690V Size 000 to 4a



Cd/Pb-free

with non-isolated gripping lugs, double indicator, contact blades, complying with DIN VDE 0636 Part 201 and IEC 60269-2-1

NH-fuses, 690VAC aM

Size	Rated current I_N (A)	Power dissipation (W)	FS ref.-no.	Previous ref.	Micro-switch ⁽¹⁾	weight kg/pce	pack.	Catalog Number
000	2	0,1	P227851	2C613.	Y	0,13	3	NH000AM69V2
000	4	0,2	Q227852	2C619.	Y	0,13	3	NH000AM69V4
000	6	0,3	R227853	2C623.	Y	0,13	3	NH000AM69V6
000	10	0,5	S227854	2C631.	Y	0,13	3	NH000AM69V10
000	16	0,7	T227855	2C635.	Y	0,13	3	NH000AM69V16
000	20	0,9	V227856	2C637.	Y	0,13	3	NH000AM69V20
000	25	1,2	W227857	2C639.	Y	0,13	3	NH000AM69V25
000	32	1,5	X227858	2C643.	Y	0,13	3	NH000AM69V32
000	35	1,6	Y227859	2C645.	Y	0,13	3	NH000AM69V35
000	40	1,8	Z227860	2C647.	Y	0,13	3	NH000AM69V40
000	50	2,3	A227861	2C651.	Y	0,13	3	NH000AM69V50
000	63	2,9	B227862	2C655.	Y	0,13	3	NH000AM69V63
00	50	2,3	D227864	2C751.	Y	0,20	3	NH00AM69V50
00	63	2,9	E227865	2C755.	Y	0,20	3	NH00AM69V63
00	80	3,6	F227866	2C759.	Y	0,20	3	NH00AM69V80
00	100	5,2	G227867	2C763.	Y	0,20	3	NH00AM69V100
00	125	6,4	H227868	2C765.	Y	0,20	3	NH00AM69V125
0	6	0,3	K227870	2C023.	Y	0,26	3	NH0AM69V6
0	10	0,5	L227871	2C031.	Y	0,26	3	NH0AM69V10
0	16	0,8	M227872	2C035.	Y	0,26	3	NH0AM69V16
0	20	1,0	N227873	2C037.	Y	0,26	3	NH0AM69V20
0	25	1,3	P227874	2C039.	Y	0,26	3	NH0AM69V25
0	32	1,6	Q227875	2C043.	Y	0,26	3	NH0AM69V32
0	35	1,7	R227876	2C045.	Y	0,26	3	NH0AM69V35
0	40	2,0	S227877	2C047.	Y	0,26	3	NH0AM69V40
0	50	2,8	T227878	2C051.	Y	0,26	3	NH0AM69V50
0	63	3,4	V227879	2C055.	Y	0,26	3	NH0AM69V63
0	80	4,9	W227880	2C059.	Y	0,26	3	NH0AM69V80
0	100	6,0	X227881	2C063.	Y	0,26	3	NH0AM69V100
0	125	7,9	Y227882	2C065.	Y	0,26	3	NH0AM69V125
0	160	10,5	Z227883	2C069.	Y	0,26	3	NH0AM69V160
1	16	1,0	B227885	2C135.	Y	0,43	3	NH1AM69V16
1	20	1,2	C227886	2C137.	Y	0,43	3	NH1AM69V20
1	25	1,4	D227887	2C139.	Y	0,43	3	NH1AM69V25
1	32	1,9	E227888	2C143.	Y	0,43	3	NH1AM69V32
1	35	2,0	F227889	2C145.	Y	0,43	3	NH1AM69V35
1	40	2,3	G227890	2C147.	Y	0,43	3	NH1AM69V40
1	50	2,9	H227891	2C151.	Y	0,43	3	NH1AM69V50
1	63	3,6	J227892	2C155.	Y	0,43	3	NH1AM69V63
1	80	4,6	K227893	2C159.	Y	0,43	3	NH1AM69V80
1	100	5,8	L227894	2C163.	Y	0,43	3	NH1AM69V100
1	125	7,5	M227895	2C165.	Y	0,43	3	NH1AM69V125
1	160	10,4	N227896	2C169.	Y	0,43	3	NH1AM69V160
1	200	14,2	P227897	2C171.	Y	0,43	3	NH1AM69V200
1	224	15,8	Q227898	2C173.	Y	0,43	3	NH1AM69V224
1	250	17,5	R227899	2C175.	Y	0,43	3	NH1AM69V250

(1) Suitable for Microswitch describes page 106

General Purpose IEC Fuses



NH Fuses (Plain Blades) aM 500V, 690V aM 690V Size 000 to 4a



Cd/Pb-free

NH-fuses, 690VAC aM

with non-isolated gripping lugs, double indicator, contact blades, complying with DIN VDE 0636 Part 201 and IEC 60269-2-1

Size	Rated current I_N (A)	Power dissipation (W)	FS ref.-no.	Previous ref.	Micro- switch ⁽¹⁾	weight kg/pce	pack.	Catalog Number
2	35	1,8	L227963	2C245.	Y	0,64	3	NH2AM69V35
2	40	2,1	M227964	2C247.	Y	0,64	3	NH2AM69V40
2	50	2,7	N227965	2C251.	Y	0,64	3	NH2AM69V50
2	63	3,4	P227966	2C255.	Y	0,64	3	NH2AM69V63
2	80	4,4	Q227967	2C259.	Y	0,64	3	NH2AM69V80
2	100	5,5	R227968	2C263.	Y	0,64	3	NH2AM69V100
2	125	6,4	S227969	2C265.	Y	0,64	3	NH2AM69V125
2	160	9,3	T227970	2C269.	Y	0,64	3	NH2AM69V160
2	200	11,3	V227971	2C271.	Y	0,64	3	NH2AM69V200
2	224	12,2	W227972	2C273.	Y	0,64	3	NH2AM69V224
2	250	16,8	X227973	2C275.	Y	0,64	3	NH2AM69V250
2	300	21,0	Y227974	2C277.	Y	0,64	3	NH2AM69V300
2	315	23,1	Z227975	2C279.	Y	0,64	3	NH2AM69V315
2	355	26,4	A227976	2C281.	Y	0,64	3	NH2AM69V355
2	400	29,7	B227977	2C283.	Y	0,64	3	NH2AM69V400
3	250	14,6	D227979	2C375.	Y	1,05	1	NH3AM69V250
3	300	21,0	E227980	2C377.	Y	1,05	1	NH3AM69V300
3	315	21,0	F227981	2C379.	Y	1,05	1	NH3AM69V315
3	355	23,3	G227982	2C381.	Y	1,05	1	NH3AM69V355
3	400	29,1	H227983	2C383.	Y	1,05	1	NH3AM69V400
3	425	29,1	J227984	2C385.	Y	1,05	1	NH3AM69V425
3	450	34,0	K227985	2C386.	Y	1,05	1	NH3AM69V450
3	500	42,0	L227986	2C387.	Y	1,05	1	NH3AM69V500
with screw contact								
4	400	26,0 *)	Q227990	8004.40056	N	2,00	1	NH4AM69V400-8
4	500	38,0 *)	R227991	8004.50056	N	2,00	1	NH4AM69V500-8
4	630	50,0 *)	S227992	8004.63056	N	1,75	1	NH4AM69V630-8
4	800	65,0 *)	T227993	8004.80056	N	1,75	1	NH4AM69V800-8
4	1000	80,0 *)	V227994	8004.10056	N	2,00	1	NH4AM69V1000-8
contact blades for NH-bottom size 4a with swivel unit								
4a	500	38,0 *)	X227996	8014.50056	N	1,95	1	NH4AM69V500-8
4a	630	50,0 *)	Y227997	8014.63056	N	1,95	1	NH4AM69V630-8
4a	800	65,0 *)	A227999	8014.80056	N	1,95	1	NH4AM69V800-8
4a	1000	80,0 *)	B228000	8014.10056	N	1,95	1	NH4AM69V1000-8

*) with indicator on top

(1) Suitable for Microswitch describes page 106

General Purpose IEC Fuses

NH Fuses (Plain Blades)
aM 500V, 690V
aM Curves Set



NH-fuses, 500VAC aM

Current Limitation Curves

Total Clearing I²t

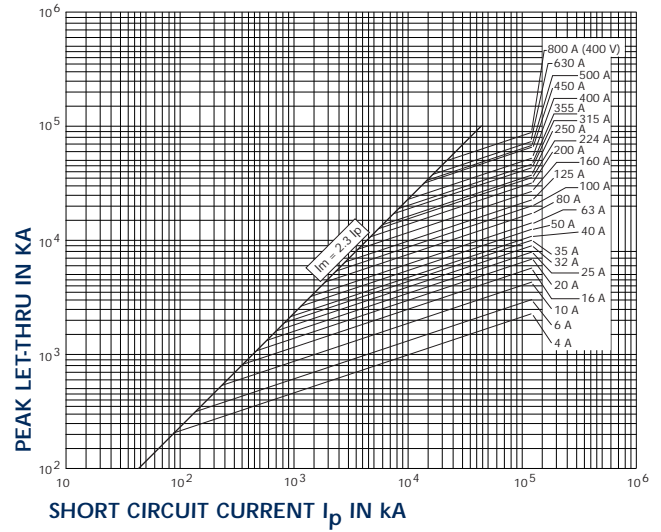
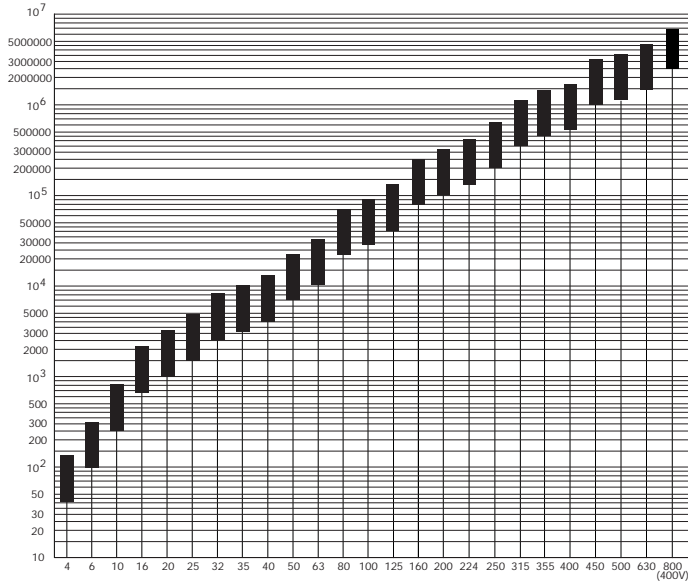

Time VS. Current Characteristics

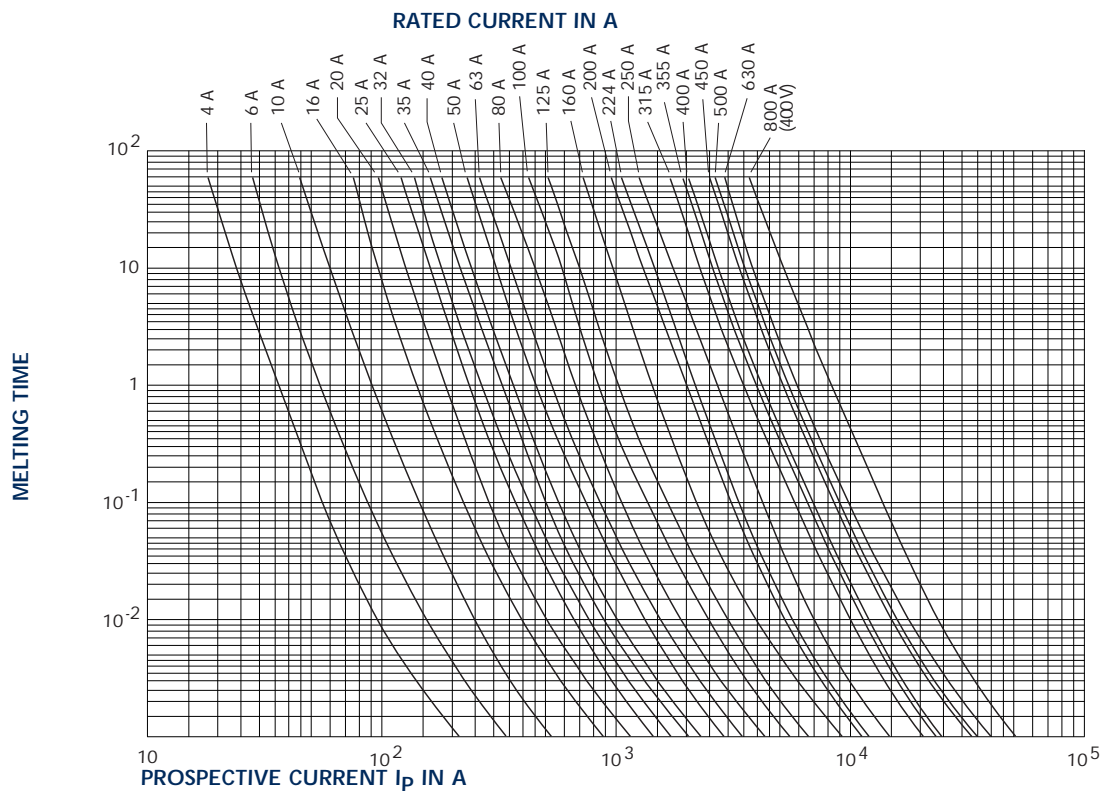

General Purpose IEC Fuses



NH Fuses (Plain Blades) aM 500V, 690V aM Curves Set

NH-fuses, 690VAC aM Total Clearing I^2t

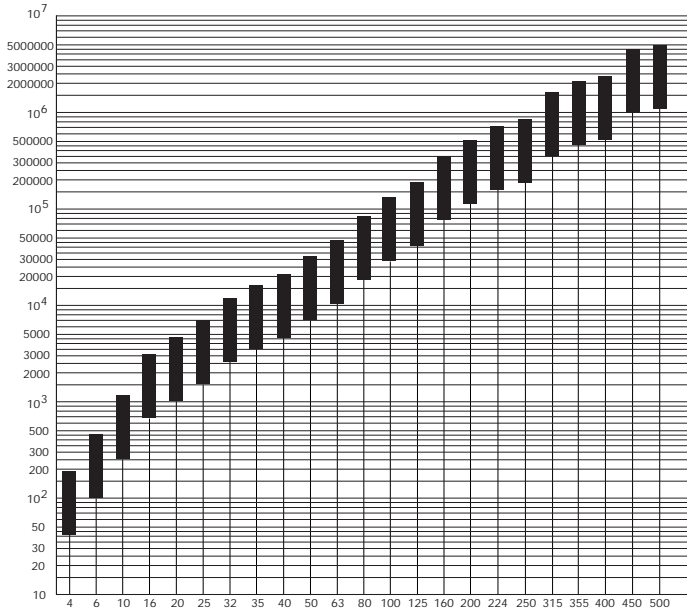

Current Limitation Curves

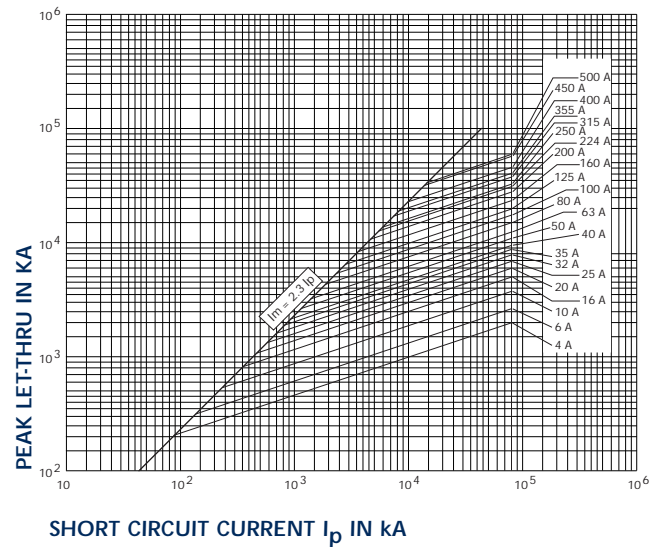

Time VS. Current Characteristics

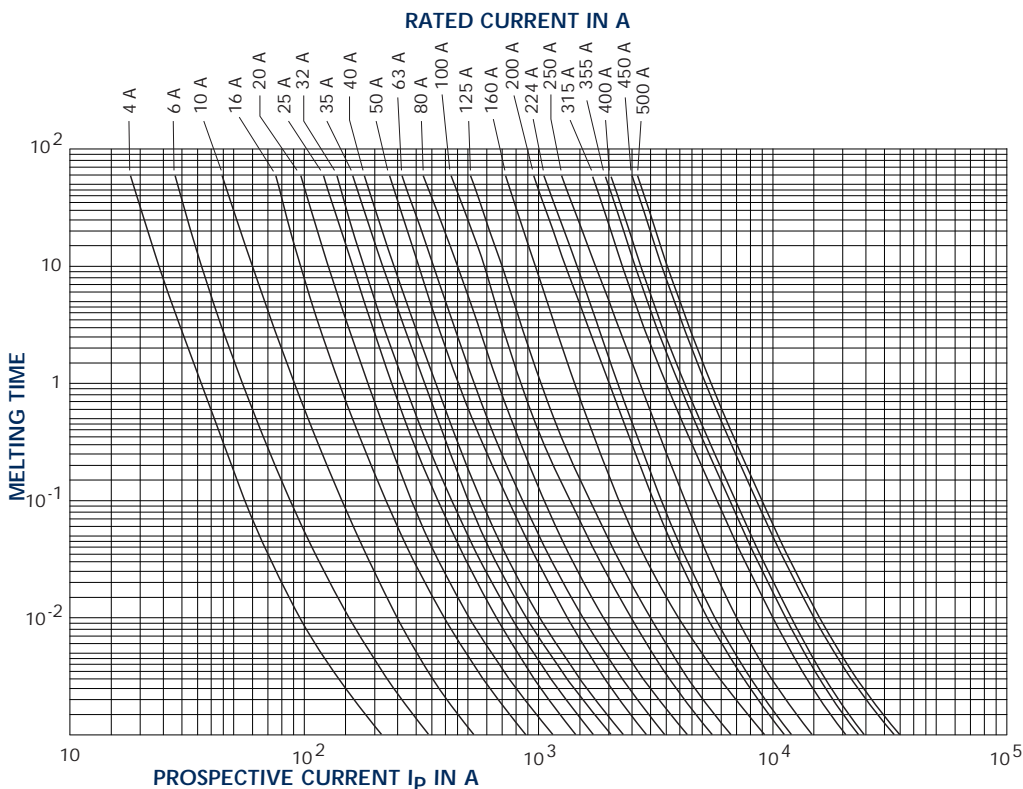

General Purpose IEC Fuses



NH Fuses (Plain Blades) 400V gTr

NH-fuses, 400VAC gTr

with non-isolated gripping lugs, double indicator, contact blades, complying with DIN VDE 0636 Part 22, DIN VDE 0636 Part 201

Size	Voltage	Transformer capacity (kVA)	Rated current I_N (A)	Power dissipation (W)	FS ref.-no.	Previous ref.	weight kg/pce	pack.	Catalog Number
2	400	50,0	72		H232813 ⁽²⁾	5A251.	0,37	1	NH2GTR50KVA
2	400	75,0	108		G232812 ⁽²⁾	5A257.	0,37	1	NH2GTR75KVA
2	400	100,0	145	12,0	B232807 ⁽²⁾	5A263.	0,37	1	NH2GTR100KVA
2	400	125,0	181	15,0	C232808 ⁽²⁾	5A265.	0,37	1	NH2GTR125KVA
2	400	160,0	231	18,4	D232809 ⁽²⁾	5A269.	0,37	1	NH2GTR160KVA
2	400	200,0	289	22,0	E232810 ⁽²⁾	5A271.	0,37	1	NH2GTR200KVA
2	400	250,0	361	27,0	F232811 ⁽²⁾	5A275.	0,37	1	NH2GTR250KVA
3	400	250,0	361	26,0	J232814 ⁽²⁾	5A375.	0,61	1	NH3GTR250KVA
3	400	315,0	455	34,0	K232815 ⁽²⁾	5A379.	0,61	1	NH3GTR315KVA
3	400	400,0	578	39,0	L232816 ⁽²⁾	5A383.	0,61	1	NH3GTR400KVA
3	400	500,0	723		M232817	5A387.	0,81	1	NH3GTR500KVA
3	400	630,0	910		N232818	5A389.	0,81	1	NH3GTR630KVA

contact blades for NH-bottom size 4a with swivel unit

4a	400	100,0	145	11,4	*)	T212997	8008.100005	2,09	1	NH4AGTR100KVA-8
4a	400	125,0	181	14,5	*)	Y213507	8008.125005	2,17	1	NH4AGTR125KVA-8
4a	400	160,0	231	17,8	*)	Z214014	8008.160005	1,95	1	NH4AGTR160KVA-8
4a	400	200,0	289	20,6	*)	C214523	8008.200005	1,95	1	NH4AGTR200KVA-8
4a	400	250,0	361	25,7	*)	F215032	8008.250005	2,13	1	NH4AGTR250KVA-8
4a	400	315,0	455	33,2	*)	M215544	8008.315005	1,95	1	NH4AGTR315KVA-8
4a	400	400,0	578	38,1	*)	S216055	8008.400005	1,95	1	NH4AGTR400KVA-8
4a	400	500,0	723	53,2	*)	V216563	8008.500005	1,95	1	NH4AGTR500KVA-8
4a	400	630,0	910	68,7	*)	E217078	8008.630005	1,95	1	NH4AGTR630KVA-8
4a	400	800,0	1155	90,4	*)	R217595	8008.800005	2,10	1	NH4AGTR800KVA-8

*) with indicator on top

⁽²⁾ These fuses are able to operate at 500VAC (tested at 550V +0 +5%).

General Purpose IEC Fuses



NH Fuses (Plain Blades) 400V gTr gTr Curves Set

NH-fuses, 400VAC gTr

Time VS. Current Characteristics

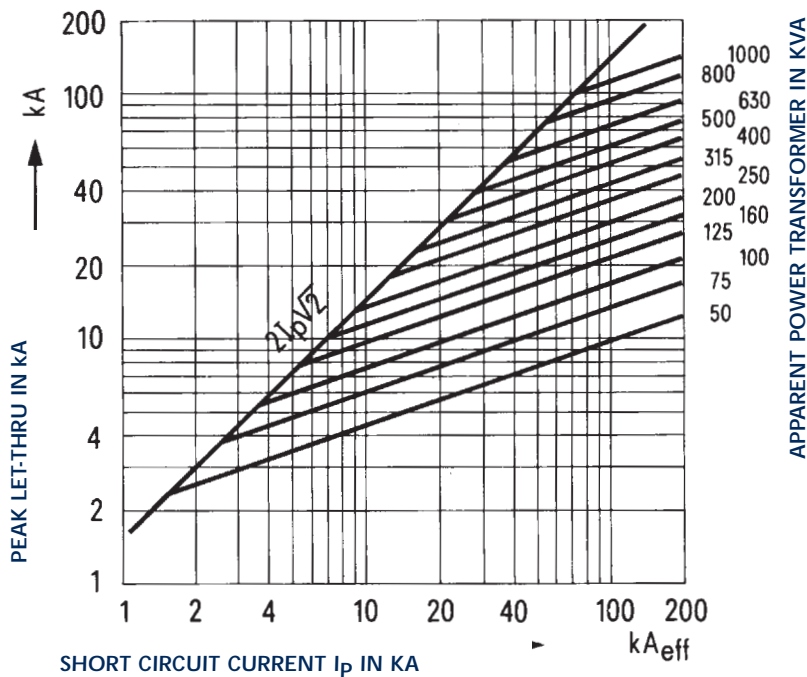
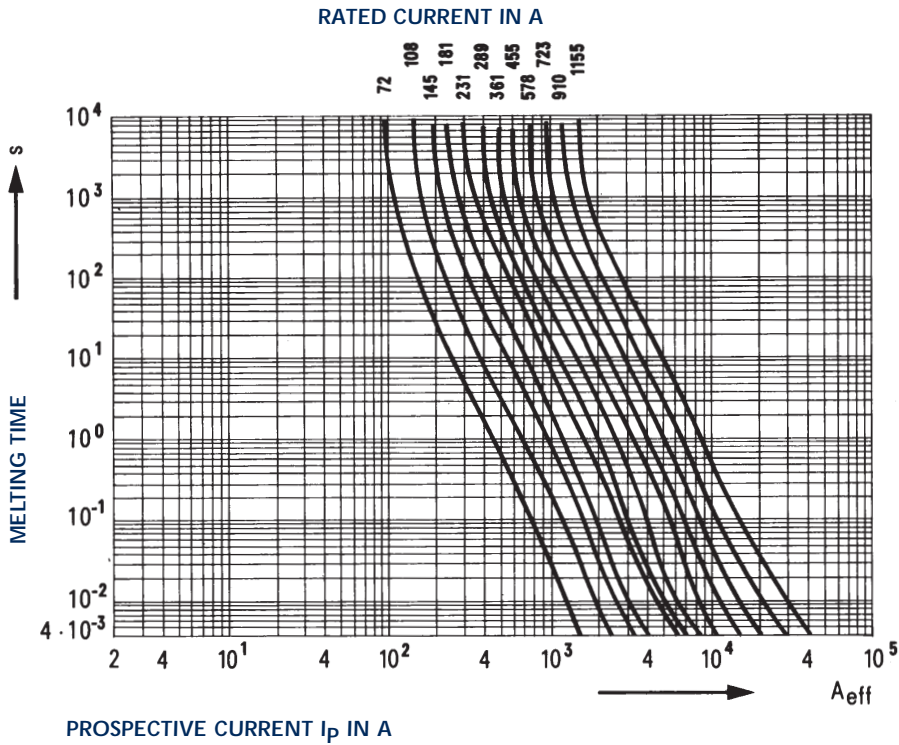

General Purpose IEC Fuses



NH Fuses (Plain Blades) gG/aM Mechanics for ceramic Body

NH Fuses-links

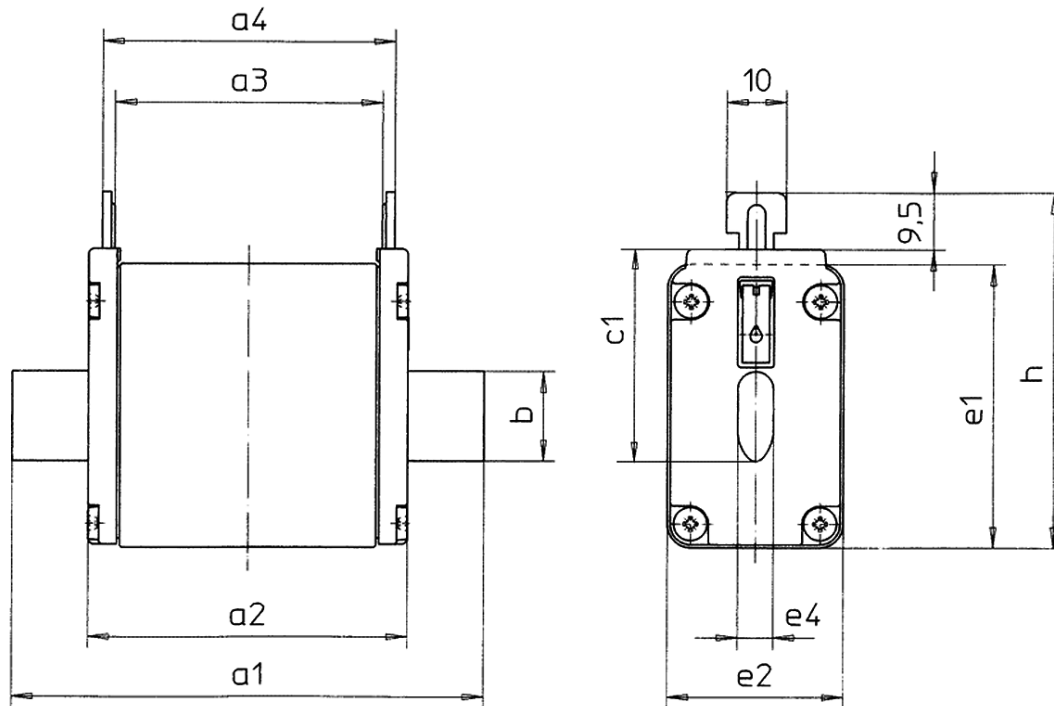

Size	Rated current $I_N(A)$	a1	a2	a3	a4	b	c1	e1	e2	e4	h
Standard 400V and 500V gG with non-isolated gripping lugs											
size 000	2 – 100A	79	52	45,5	49,5	15	35	40,5	20,8	6	52,5
size 00	125/160A	79	52,8	45	50	15	35	47,5	29,5	6	59,5
size 0	2 – 160A (500V)	125	66,8	61	66	15	35	47,5	29,5	6	59,5
size 116	100A (500V), 16 – 125A (400V)	135	70,8	63	68	15	40	47,5	29,5	6	64,5
size 1125	355A (500V), 160 – 250A (400V)	135	70,8	63	68	20	40	52,5	39,5	6	64,5
size 2	16 – 250A	150	72,3	63	68	20	48	52,5	39,5	6	72,5
size 2	300 – 500A	150	72,3	63	68	26	48	60	51	6	72
size 3	250 – 400A	150	72,3	63	68	26	60	60	51	6	83,5
size 3	425 – 800A	150	72,3	63	68	33	60	74	70	6	86
size 4	400 – 1250A	200	85	62	68	49	86	108	90	8	117,5
size 4a	500 – 1250A	200	85	84	90	49	86	108	90	6	117,5
Standard 400V and 500V gG (SGL) with isolated gripping lugs											
size 000	2 – 100A	78	53,4	45,7	49,7	15	35	40,5	20,8	6	52,5
size 00	125/160A	79	53,5	44,8	49	15	35	47,5	29,5	6	59,5
size 0	2 – 160A (500V)	125	67,5	62,5	66,7	15	35	47,5	29,5	6	59,5
size 116	100A (500V), 16 – 125A (400V)	135	71,5	62,8	67	15	40	47,5	29,5	6	64,5
size 1125	250A (500V), 160 – 250A (400V)	135	73,4	63	67,2	20	40	52,5	39,5	6	64,5
size 2	16 – 250A	150	73,4	63	67,2	20	48	52,5	39,5	6	72,5

General Purpose IEC Fuses

NH Fuses (Plain Blades) gG/aM Mechanics for ceramic Body

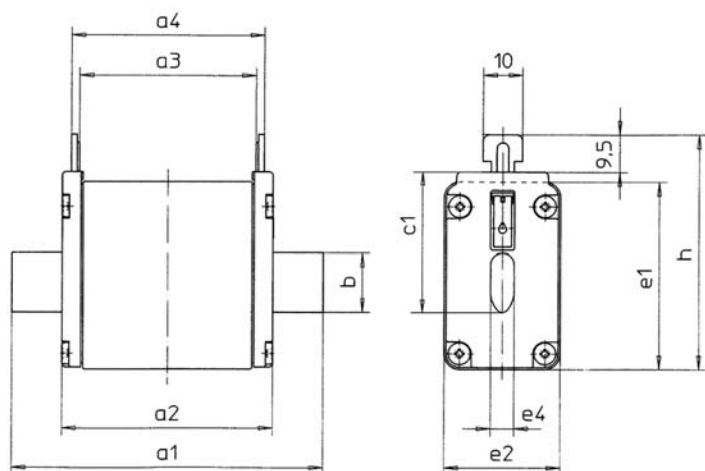

NH Fuses-links

Size	Rated current I_N (A)	a1	a2	a3	a4	b	c1	e1	e2	e4	h
size 2	300 – 400A	150	73,4	63	67,2	26	48	60	51	6	72
size 3	250 – 400A	150	73,4	63	68	26	60	60	51	6	83,5
size 3	425 – 630A	150	73,4	63	68	33	60	74	70	6	86
NH 690V gG with non-isolated gripping lugs											
size 000	2 – 35A	79	53,8	45	49	15	35,8	40	20	6	47,8
size 00	40 – 100A	79	53,8	45	49	15	35,8	48	30	6	47,8
size 1	16 – 160A	135	75	64	68	20	40	44	30	6	52
size 1	200 – 250A	135	75	64	68	20	40	47	39	6	52
size 2	35 – 100A	150	75	64	68	26	48	44	30	6	60
size 2	125 – 315A	150	75	64	68	26	60	47	39	6	72
size 3	250 – 300A	150	75	64	68	26	60	47	39	6	72
size 3	315 – 425A	150	75	64	68	33	60	58	51	6	72
size 3	500A	150	75	64	68	33	70	64	64	6	72
size 4	400 – 800A	200	85	62	68	49	86	108	90	8	117,5
size 4a	400 – 800A	200	85	84	90	49	86	108	90	6	117,5
NH 690V gG (SGL) with isolated gripping lugs											
size 000	2 – 35A	79	53,8	45	49	15	35,8	40,5	21	6	47,8
size 0	40 – 125A	79	53,8	45	49	15	35,8	40,5	30	6	47,8
size 1	35 – 200A	135	75	64	68	20	40	51	39	6	52
size 2	32 – 200A	150	75	64	68	26	48	51	39	6	60
size 2	250 – 315A	150	75	64	68	26	48	60	46	6	60
size 3	250 – 315A	150	73,4	63	68	26	60	60	51	6	83,5
size 3	350 – 425A	150	73,4	63	68	33	60	74	70	6	86
NH 500V aM with non-isolated gripping lugs											
size 000	2 – 80A	79	53,8	45	49	15	35,8	40,5	21	6	47,8
size 00	100 – 160A	79	53,8	45	49	15	35,8	40,5	30	6	47,8
size 0	100 – 200A	125	68	64	68	15	35,8	44	30	6	47,8
size 1	160 – 250A	135	75	64	68	20	40	47	39	6	52
size 2	250 – 500A	150	75	64	68	26	48	47	39	6	60
size 3	315 – 630A	150	75	64	68	33	60	58	51	6	72
size 4	630 – 1250A	200	85	62	68	49	86	108	90	8	117,5
NH 690V aM with non-isolated gripping lugs											
size 000	2 – 80A	79	52	45,5	49,5	15	35	40,5	20,8	6	52,5
size 00	50 – 160A	79	52,8	45	50	15	35	47,5	29,5	6	59,5
size 0	6 – 200A	125	66,8	61	66	15	35	47,5	29,5	6	59,5
size 1	16 – 315A	135	70,8	63	68	20	40	52,5	39,5	6	64,5
size 2	35 – 500A	150	72,3	63	68	26	48	60	51	6	72
size 3	250 – 630A	150	72,3	63	68	33	60	74	70	6	86
size 4	400 – 1250A	200	85	62	68	49	86	108	90	8	117,5
size 4a	500 – 1250A	200	85	84	90	49	86	108	90	6	117,5
NH 400/500V gTr with non-isolated gripping lugs											
size 2	50 – 250kVA	150	72,3	63	68	26	48	60	51	6	72
size 3	250 – 400kVA (500V), 500 – 630kVA (400V)	150	72,3	63	68	33	60	74	70	6	86
size 4a	100 – 800kVA	200	85	84	90	49	86	108	90	6	117,5

General Purpose IEC Fuses

NH Fuses (Plain Blades) Microswitch indication system for NH-fuses size 000 to 3 with non-isolated gripping lugs



FS ref.-no.	Designation	weight g/piece	pack. unit	Catalog Number
2,8mm clips, automatically resettable G210157	MS 4L 2-5 B2 + PRES	26	3	MS4L2-5B2PRES
6,3mm clips, automatically resettable F210156	MS 4L 2-5 B6 + PRES	30	3	MS4L2-5B6PRES

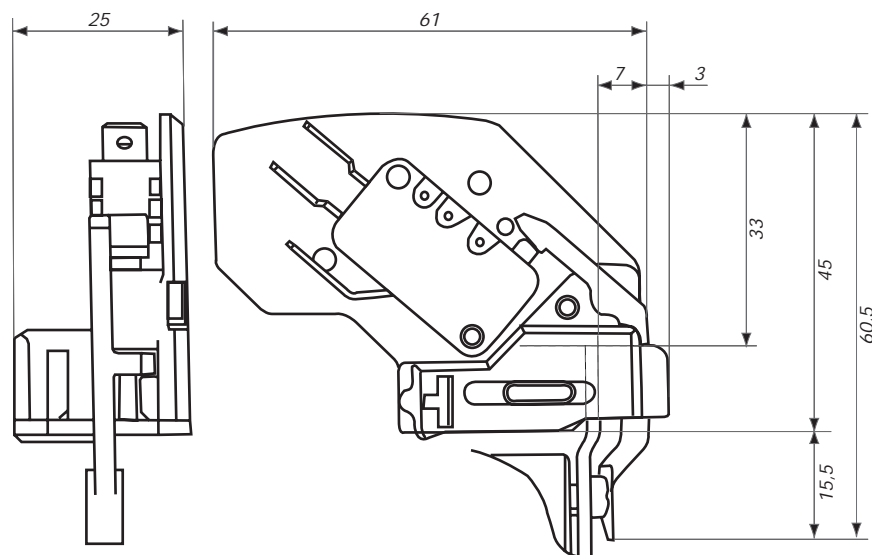

Automatically resettable, these microswitch systems indicate fuse presence (PRES) and proper mounting.

In case of improper mounting or fuse melting, this is indicated (terminal 1-4 closed).

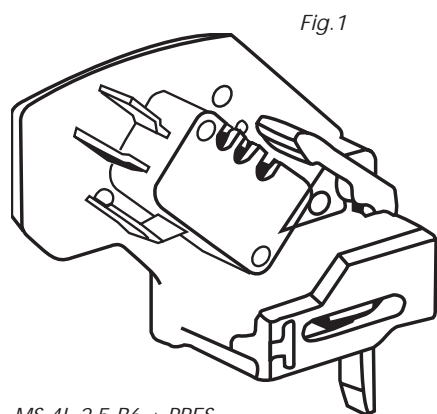

MS 4L 2-5 B6 + PRES
F210156
6,3mm clips

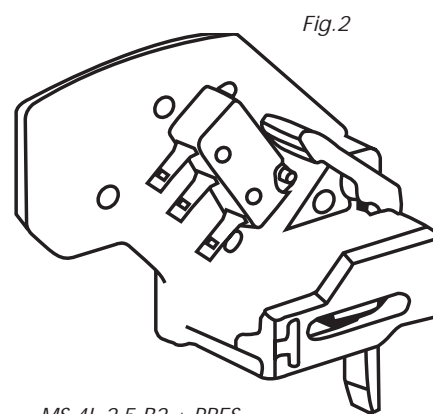

MS 4L 2-5 B2 + PRES
G210157
2,8mm clips

General Purpose IEC Fuses

NH Fuses (Plain Blades) gG Ceramic body with French striker gG 690V Size 0 to 3



H216690



R223000



X214656



N219271

Size	Rated current I_N (A)	Rated voltage (V)	Previous ref.	Ref.-no.	Breaking capacity	Catalog Number
0	32	690V	36443	P213637	80kA - 690V	NH0GG69V32P-2
0	35	690V	36445	S214146	80kA - 690V	NH0GG69V35P-2
0	40	690V	36447	W214655	80kA - 690V	NH0GG69V40P-2
0	50	690V	36451	B215166	80kA - 690V	NH0GG69V50P-2
0	63	690V	36455	D215674	80kA - 690V	NH0GG69V63P-2
0	80	690V	36459	J216185	80kA - 690V	NH0GG69V80P-2
0	100	690V	36463	H216690	80kA - 690V	NH0GG69V100P-2
0	125	500V	36465	V217207	120kA - 500V	NH0GG50V125P-2
0	160	500V	36469	A217718	120kA - 500V	NH0GG50V160-2
0	200	500V	36471	K218233	120kA - 500V	NH0GG50V200P-2
1	80	690V	36559	Y218751	80kA - 690V	NH1GG69V80P-2
1	100	690V	36563	M219270	80kA - 690V	NH1GG69V100P-2
1	125	690V	36565	P219801	80kA - 690V	NH1GG69V125P-2
1	160	690V	36569	Z222478	80kA - 690V	NH1GG69V160P-2
1	200	690V	36571	R223000	80kA - 690V	NH1GG69V200P-2
1	224	500V	36573	Y200788	120kA - 500V	NH1GG50V224P-2
1	250	500V	36575	Q201333	120kA - 500V	NH1GG50V250P-2
1	315	500V	36579	Z201847	120kA - 500V	NH1GG50V315P-2
1	355	500V	36581	W211067	120kA - 500V	NH1GG50V355P-2
2	125	690V	36665	W212102	80kA - 690V	NH2GG69V125P-2
2	160	690V	36669	L212622	80kA - 690V	NH2GG69V160P-2
2	200	690V	36671	Y213139	80kA - 690V	NH2GG69V200P-2
2	224	690V	36673	Q213638	80kA - 690V	NH2GG69V224P-2
2	250	690V	36675	T214147	80kA - 690V	NH2GG69V250P-2
2	315	690V	36679	X214656	80kA - 690V	NH2GG69V315P-2
2	355	500V	36681	E215675	120kA - 500V	NH2GG69V355P-2
2	400	500V	36683	K216186	120kA - 500V	NH2GG50V400P-2
2	500	500V	36687	W217208	120kA - 500V	NH2GG50V500P-2
3	315	690V	36779	B217719	80kA - 690V	NH3GG69V315P-2
3	355	690V	36781	L218234	80kA - 690V	NH3GG69V355P-2
3	400	690V	36783	Z218752	80kA - 690V	NH3GG69V400P-2
3	500	690V	36787	N219271	80kA - 690V	NH3GG69V500P-2
3	630	500V	36789	Q219802	120kA - 500V	NH3GG50V630P-2

Pack. : 3 pieces

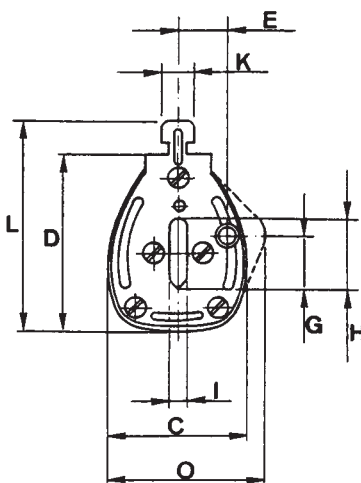
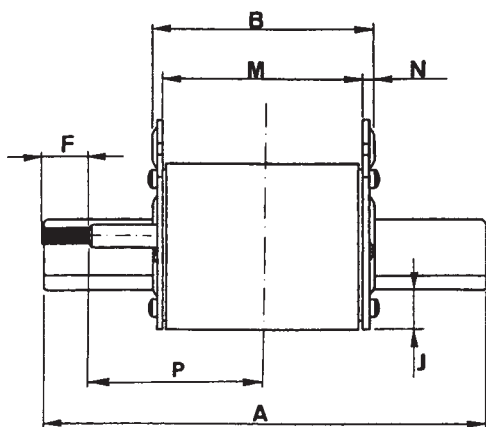

Dimensions

	0	1	2	3
A	124.5	134.5	150	150
B	66	67	67	67
C	39	40	56	69
D	49	55	62.5	76
E	14.5	16	19	24
F	15.5	15.5	15.5	15.5
G	14	14.5	14.5	14.5
H	15	20	26	32
I	6	6	6	6
J	14	14	15	16
K	10	10	10	10
L	59	65	72.5	86
M	60	61	61	61
N	3	3	3	3
O	41.5	45	-	-
P	47	52	60	60

General Purpose IEC Fuses



NH Fuses (Plain Blades)
 gG Ceramic body with French striker
 gG 690V Size 0 to 3

gG 500 - 690VAC

MELTING TIME - CURRENT DATA - 6-800 AMPERES

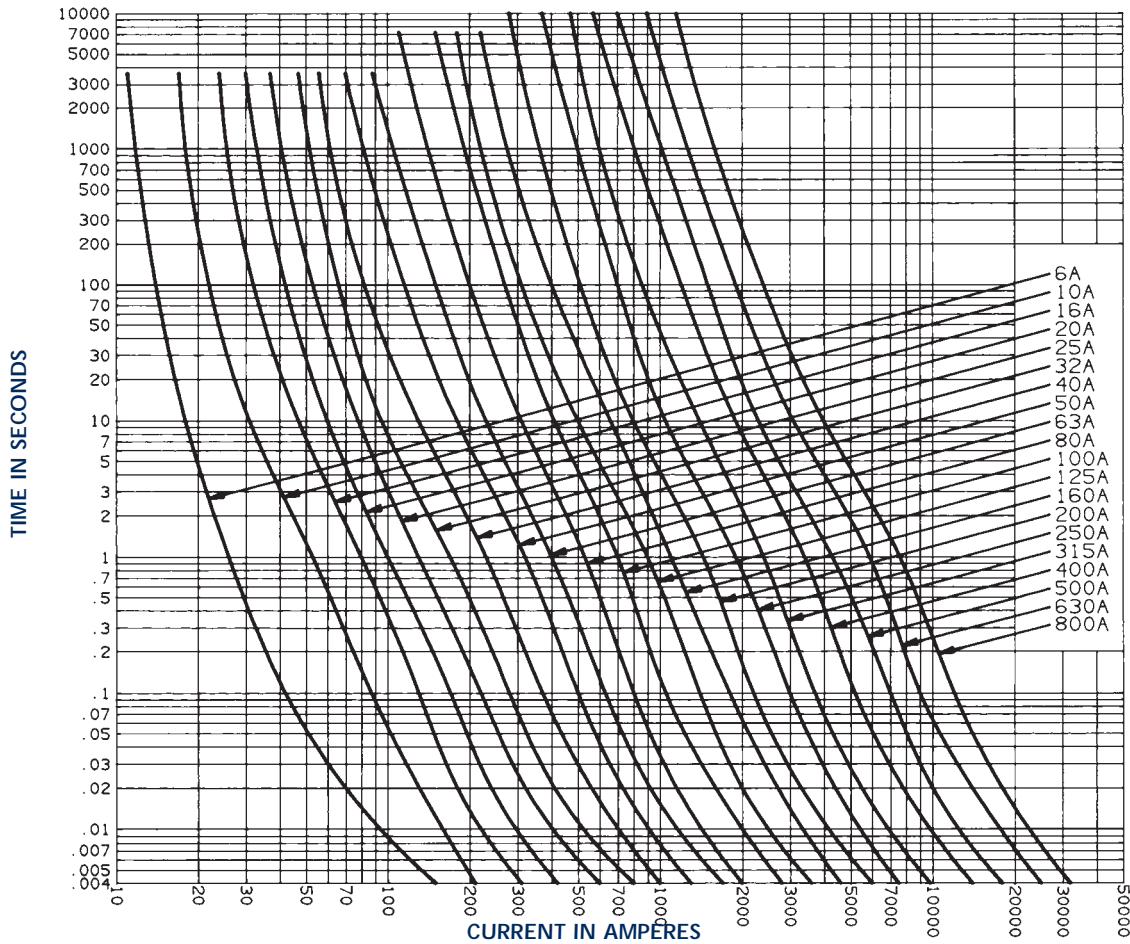

PEAK LET-THRU CURRENT DATA - 6-800 AMPERES

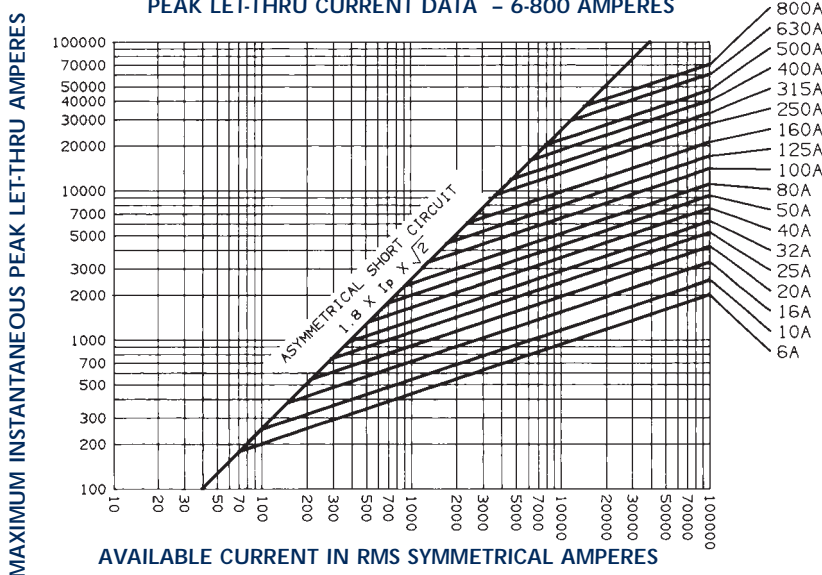

Striker



General Purpose IEC Fuses

NH Fuses (Plain Blades)
gG Ceramic body with French striker
gG 690V Size 0 to 3



gG 500 - 690VAC

Power Loss (Watts) at Rated Current

Rated current I_N (A)	Size			
	0	1	2	3
32	3.7 W			
35	4.0 W			
40	4.5 W			
50	5.2 W			
63	6.2 W			
80	7.5 W	6.9 W		
100	8.5 W	8.1 W		
125	10.7 W	9.6 W	9.5 W	
160	13.5 W	11.9 W	11.5 W	
200	15.0 W	14.9 W	14.5 W	
224		16.7 W	16.0 W	
250		18.7 W	17.5 W	
315		25.0 W	23.0 W	23 W
355		28.0 W	25.0 W	25 W
400			29.0 W	29 W
425			34.0 W	34 W
500			39.0 W	39 W
630				47 W
800				67 W

Typical values allowed by the standards

Rated current I_N (A)	0	1	2	3
	160A	250A	400A	630A
VDE 0660 (500V)	25 W	32 W	45 W	60 W
IEC 269-2-1 (660V)	25 W	32 W	45 W	60 W
UNE 21103 (500V)	25 W	32 W	45 W	60 W
NFC 63210 (500V)	25 W	32 W	45 W	60 W
VDE 0636 (660V)	-	23 W	34 W	48 W
VDE 0636 (500V)	16 W	23 W	34 W	48 W
IEC 269 (500V)	16 W	23 W	34 W	48 W
UNESA (500V)	17 W	26 W	32 W	48 W
WDE W (500V)	16 W	21 W	32 W	42 W

General Purpose IEC Fuses



NH Fuses (Plain Blades)
 gG Ceramic body with French striker
 gG 690V Size 0 to 3

gG 500 - 690VAC

I²T CHARACTERISTICS - DISCRIMINATION

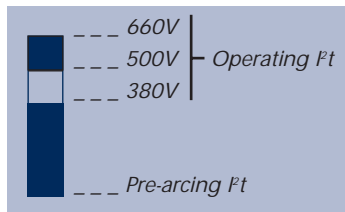
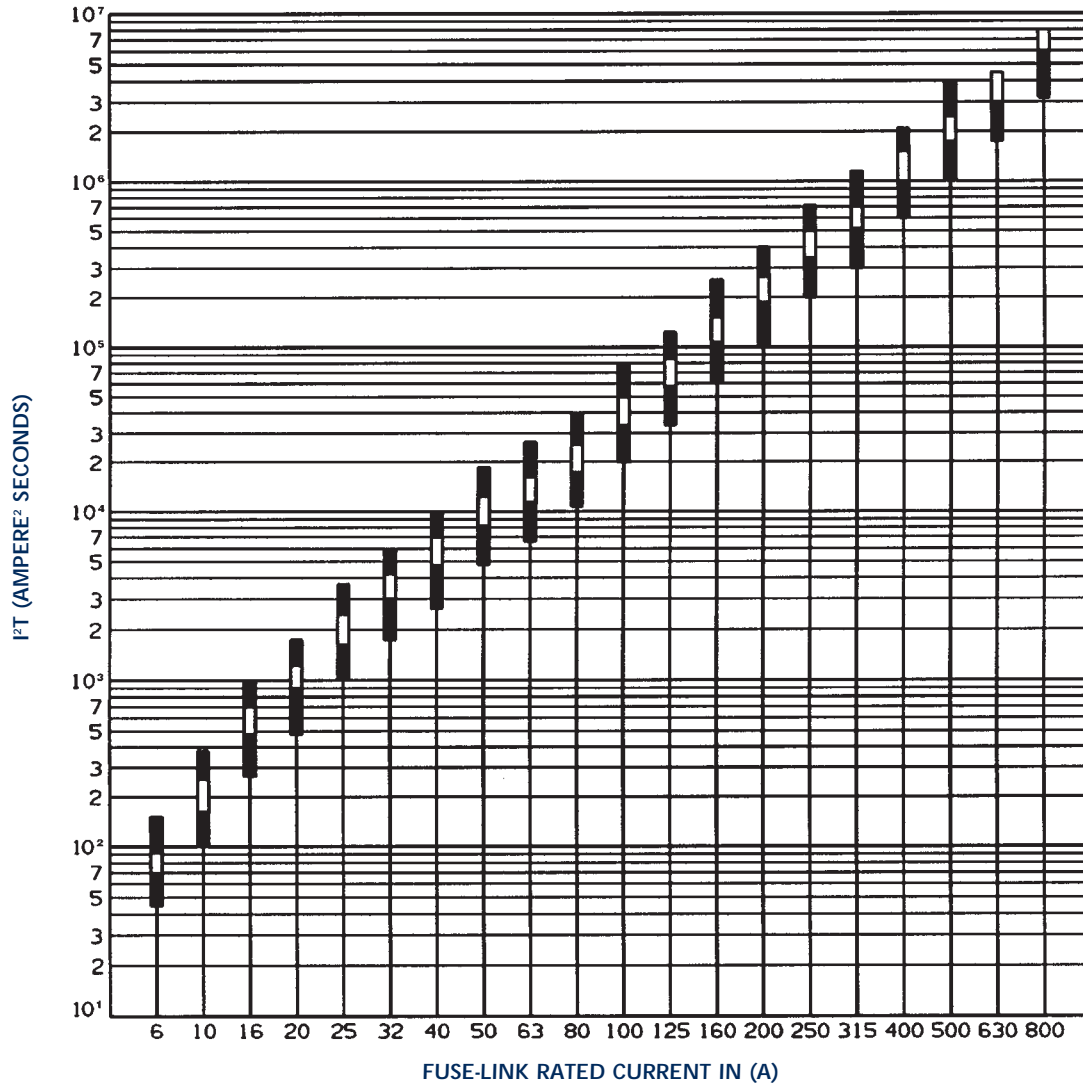

General Purpose IEC Fuses

NH Fuses (Plain Blades) aM Ceramic body with French striker aM 690V Size 0 to 3



L216187



P219272



Y212104



M216188

aM 500 - 690VAC

Size	Rated current I_N (A)	Rated voltage (V)	Previous ref.	Ref.-no.	Breaking capacity	Catalog Number
0	32	690V	37443	Z213140	80kA - 690V	NH0AM69V32P-2
0	40	690V	37447	R213639	80kA - 690V	NH0AM69V40P-2
0	50	690V	37451	V214148	80kA - 690V	NH0AM69V50P-2
0	63	690V	37455	Y214657	80kA - 690V	NH0AM69V63P-2
0	80	690V	37459	C215167	80kA - 690V	NH0AM69V80P-2
0	100	690V	37463	F215676	80kA - 690V	NH0AM69V100P-2
0	125	690V	37465	L216187	80kA - 690V	NH0AM69V125P-2
0	160	690V	37469	J216691	80kA - 690V	NH0AM69V160P-2
0	200	500V	37471	X217209	120kA - 500V	NH0AM50V200P-2
1	80	690V	37559	C217720	80kA - 690V	NH1AM69V80P-2
1	100	690V	37563	M218235	80kA - 690V	NH1AM69V100P-2
1	125	690V	37565	A218753	80kA - 690V	NH1AM69V125P-2
1	160	690V	37569	P219272	80kA - 690V	NH1AM69V160P-2
1	200	690V	37571	B222480	80kA - 690V	NH1AM69V200P-2
1	250	690V	37575	T223002	80kA - 690V	NH1AM69V250P-2
1	315	500V	37579	A200790	120kA - 500V	NH1AM50V315P-2
2	125	690V	37665	S201335	80kA - 690V	NH2AM69V125-2
2	160	690V	37669	B201849	80kA - 690V	NH2AM69V160-2
2	200	690V	37671	Y211069	80kA - 690V	NH2AM69V200-2
2	224	690V	37673	P211590	80kA - 690V	NH2AM69V224P-2
2	250	690V	37675	Y212104	80kA - 690V	NH2AM69V250-2
2	315	690V	37679	N212624	80kA - 690V	NH2AM69V315P-2
2	355	690V	37681	A213141	80kA - 690V	NH2AM69V355-2
2	400	690V	37683	S213640	80kA - 690V	NH2AM69V400-2
2	500	500V	37687	W214149	120kA - 500V	NH2AM50V500-2
3	315	690V	37779	Z214658	80kA - 690V	NH3AM69V315P-2
3	355	690V	37781	D215168	80kA - 690V	NH3AM69V355P-2
3	400	690V	37783	G215677	80kA - 690V	NH3AM69V400P-2
3	500	690V	37787	M216188	80kA - 690V	NH3AM69V500P-2
3	630	500V	37789	K216692	120kA - 500V	NH3AM50V630P-2

Pack. : 3 pieces

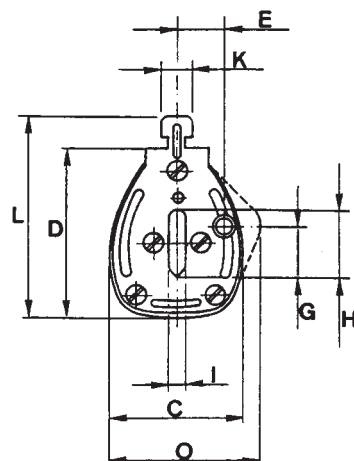
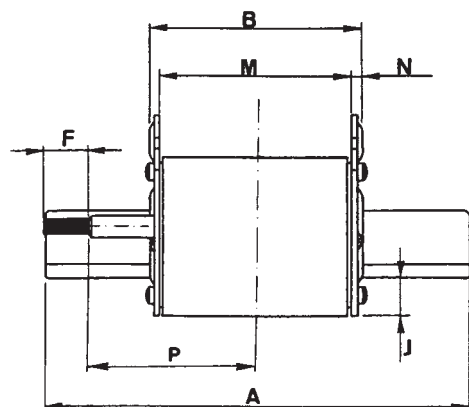

Dimensions

	0	1	2	3
A	124.5	134.5	150	150
B	66	67	67	67
C	39	40	56	69
D	49	55	62.5	76
E	14.5	16	19	24
F	15.5	15.5	15.5	15.5
G	14	14.5	14.5	14.5
H	15	20	26	32
I	6	6	6	6
J	14	14	15	16
K	10	10	10	10
L	59	65	72.5	86
M	60	61	61	61
N	3	3	3	3
O	41.5	45	-	-
P	47	52	60	60

General Purpose IEC Fuses



NH Fuses (Plain Blades)
 aM Ceramic body with French striker
 aM 690V Size 0 to 3

aM 500 - 690VAC

MELTING TIME - CURRENT DATA - 32-630 AMPERES

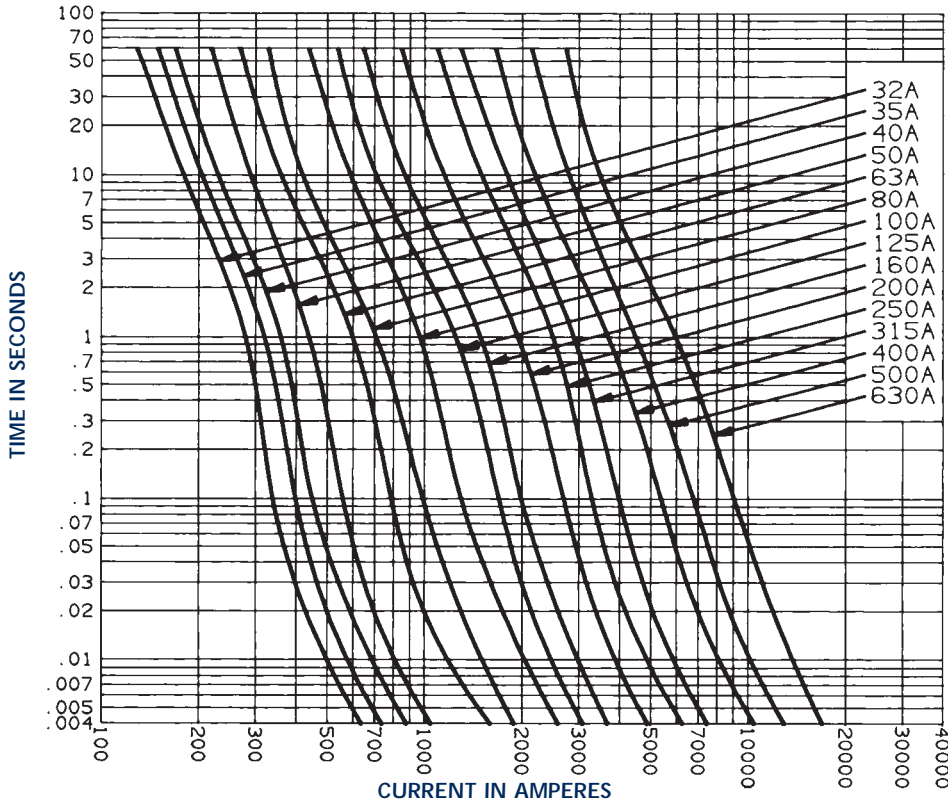

PEAK LET-THRU CURRENT DATA - 32-630 AMPERES

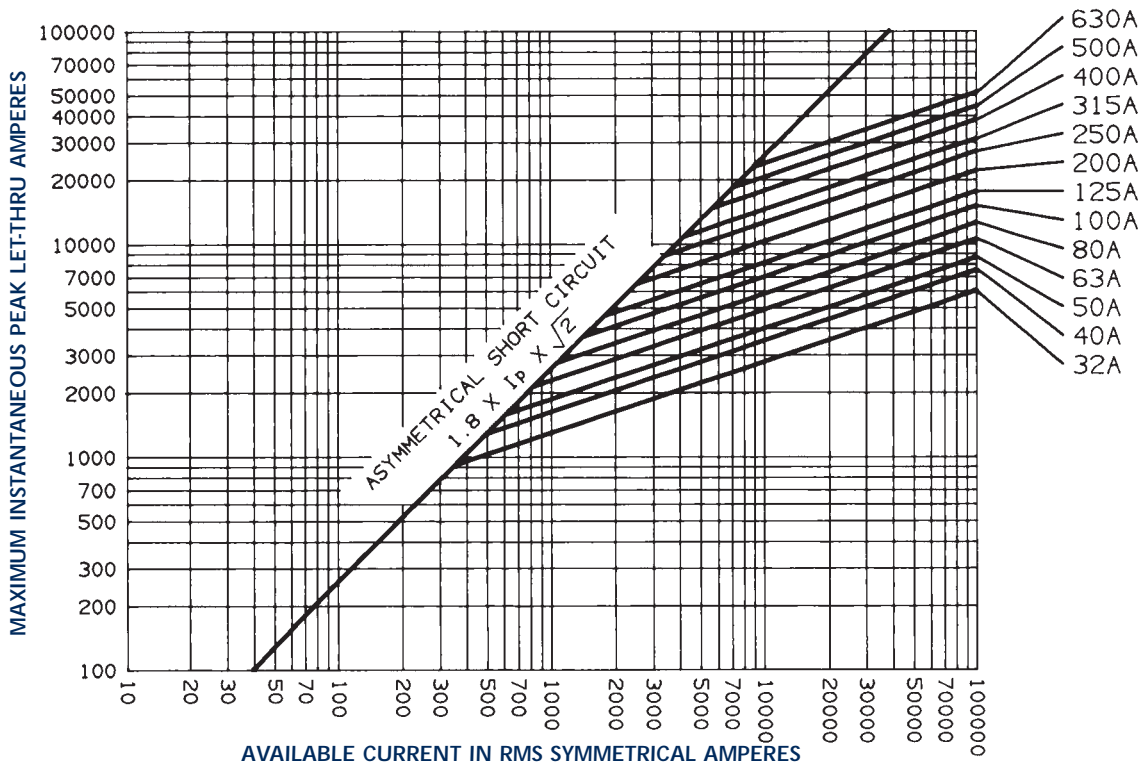

General Purpose IEC Fuses

NH Fuses (Plain Blades)
 aM Ceramic body with French striker
 aM 690V Size 0 to 3

aM 500 - 690VAC

Power Loss (Watts) at Rated Current

Rated current I_N (A)	Size			
	0	1	2	3
32	2.4 W			
40	2.8 W			
50	3.6 W			
63	4.6 W			
80	6.0 W	6.0 W		
100	7.5 W	7.5 W		
125	9.5 W	9.9 W		
160	12.0 W	12.7 W	12.7 W	
200		16.4 W	16.4 W	
224		18.7 W	18.7 W	
250		21.5 W	21.5 W	
315			29.0 W	25.0 W
355			32.0 W	29.0 W
400			34.0 W	34.0 W
425				38.5 W
500				45.0 W
630				60.0 W

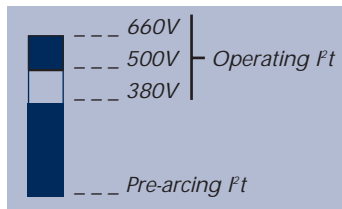

I^2T CHARACTERISTICS – DISCRIMINATION

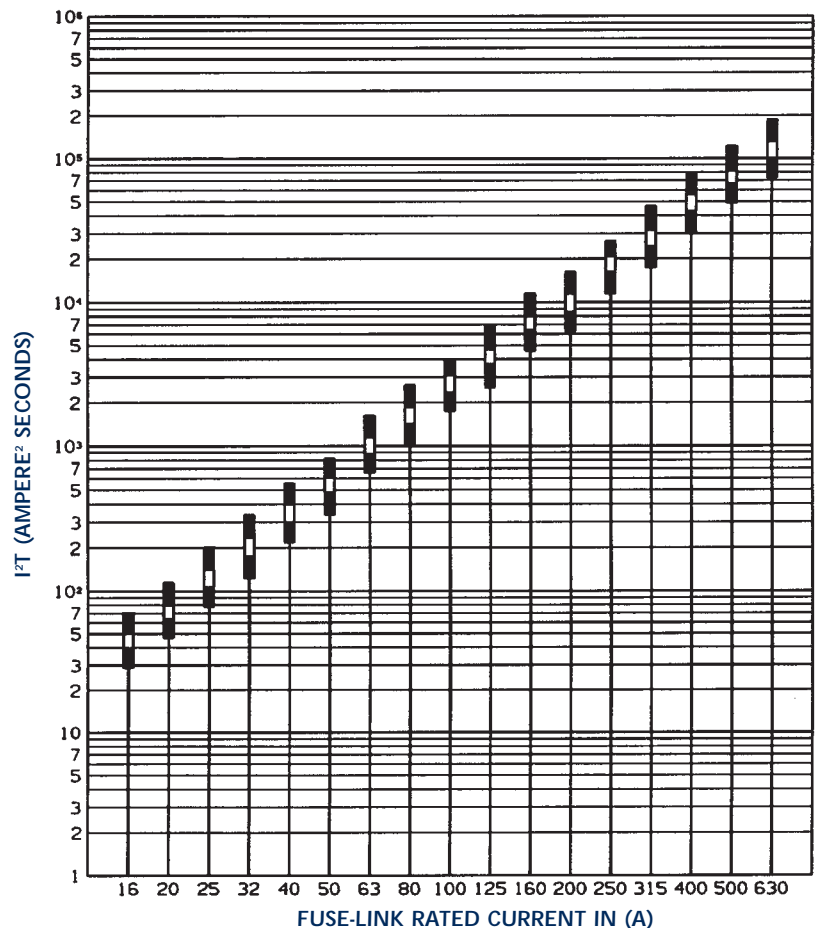

General Purpose IEC Fuses

NH Fuses (Plain Blades) gG Plastic body with/without French striker gG 500V Size 00



from 10 to 160 A

- BLADE-STYLE FUSES: WITH BLOWN FUSE INDICATOR
- COMPLYING WITH IEC 269.1 and 2.1 NF EN 60269.1 & 2 NF C 63210 AND DIN 43620 STANDARDS
- DIMENSIONS:

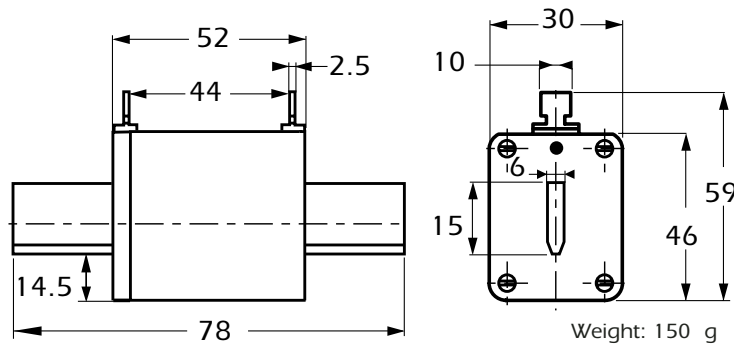

Main Characteristics

Size	Voltage rating (VAC)	Current rating IN(A)	Watts loss (W)	With BLOWN FUSE indicator		
				Designation	Reference Number	Catalog Number
00	500	10	1	gG 00 L / 10	M098290	NH00GG50V10-3
		16	1.4	gG 00 L / 16	N098291	NH00GG50V16-3
		20	1.8	gG 00 L / 20	P098292	NH00GG50V20-3
		25	2.1	gG 00 L / 25	Q098293	NH00GG50V25-3
		32	3	gG 00 L / 32	R098294	NH00GG50V32-3
		35	3	gG 00 L / 35	S098295	NH00GG50V35-3
		40	3.3	gG 00 L / 40	T098296	NH00GG50V40-3
		50	4.5	gG 00 L / 50	V098297	NH00GG50V50-3
		63	6	gG 00 L / 63	X098299	NH00GG50V63-3
		80	7	gG 00 L / 80	Z098301	NH00GG50V80-3
		100	7.5	gG 00 L / 100	A098302	NH00GG50V100-3
		125	13	gG 00 L / 125	B098303	NH00GG50V125-3
160	15	gG 00 L / 160	D098305	NH00GG50V160-3		

Accessories: Neutral link Z218269
Pull-out handle - PMP - Part # P215592

General Purpose IEC Fuses



NH Fuses (Plain Blades)

gG Plastic body with/without French striker

gG 500V Size 00

from 10 to 160 A

Total Clearing I^2t

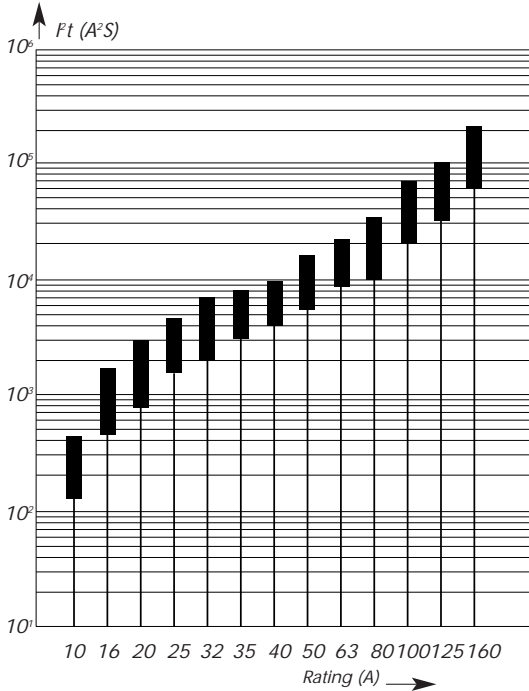

..... b: total clearing I^2t @ 500 V
 █ a: pre-arcing I^2t

Current Limitation Curves

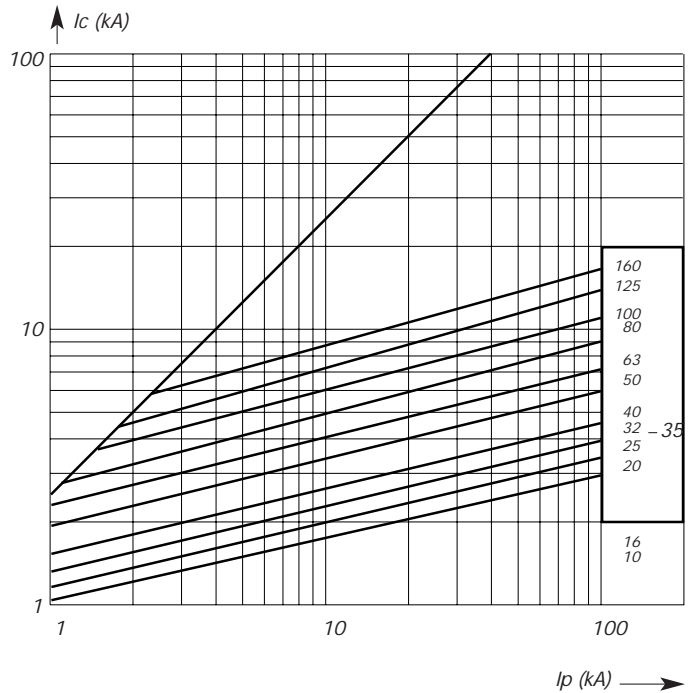

I_c = Peak let-through current
 I_p = Available fault current

Time VS. Current Characteristics

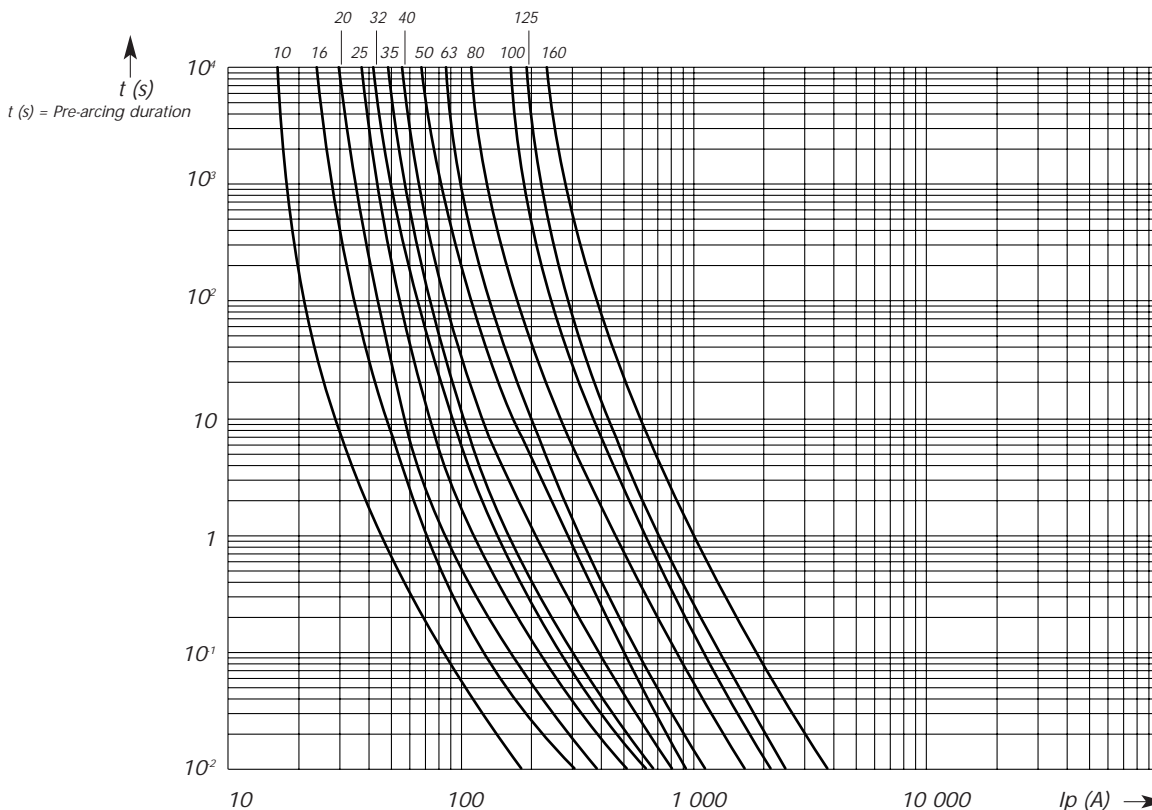

Breaking capacity
100 kA

I_p (A) = R.M.S. AVAILABLE FAULT CURRENT

General Purpose IEC Fuses



NH Fuses (Plain Blades) gG Plastic body with/without French striker gG 500V Size 0 and 1

from 40 to 250 A

- BLADE-STYLE FUSES: WITH BLOWN FUSE INDICATOR or TRIP-INDICATOR
- COMPLYING WITH IEC 269.1 AND 2.1 NF EN 60269.1 & 2 NF C 63210 - 63211 AND DIN 43620
- DIMENSIONS:

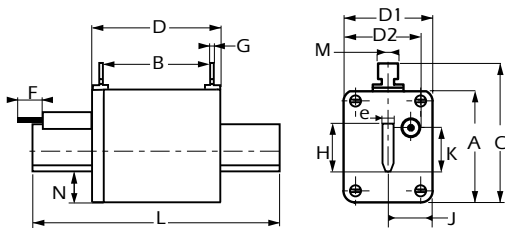

With trip-indicator

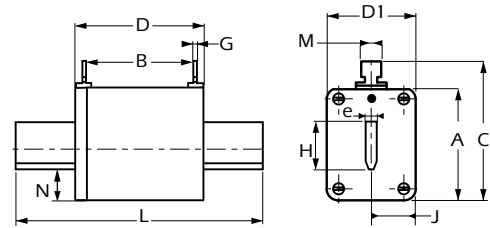

With blown fuse indicator

Size	A	B	C	D	D1	D2*	F*	G	H	J	K	L	M	N	e	Wgt.
0	46	62	59	67	36	39	14	2,5	15	14,5	14,5	125	10	14,5	6	230g
1	52	64	64	74	47	47	14	3	21	16	14,5	135	10	14,5	6	400g

* For fuses with trip-indicator

Size	Voltage rating (VAC)	Current rating I _N (A)	Watts loss (W)	With blown fuse indicator			With trip-indicator		
				Designation	Ref. Number	Catalog Number	Designation	Ref. Number	Catalog Number
0	500	40	4.2	gG 0 / 40	A095013	NH0GG50V40-3	gG 0 / 40 P	T095214	NH0GG50V40-4
		50	5.5	gG 0 / 50	B095014	NH0GG50V50-3	gG 0 / 50 P	V095215	NH0GG50V50-4
		63	6.5	gG 0 / 63	C095015	NH0GG50V63-3	gG 0 / 63 P	W095216	NH0GG50V63-4
		80	8.5	gG 0 / 80	D095016	NH0GG50V80-3	gG 0 / 80 P	Y095218	NH0GG50V80-4
		100	9.5	gG 0 / 100	E095017	NH0GG50V100-3	gG 0 / 100 P	A095220	NH0GG50V100-4
		125	12	gG 0 / 125	F095018	NH0GG50V125-3	gG 0 / 125 P	C095222	NH0GG50V125-4
		160	15	gG 0 / 160	G095019	NH0GG50V160-3	gG 0 / 160 P	G095226	NH0GG50V160-4
		200	19	gG 0 / 200	H095020	NH0GG50V200-3			
1	500	80	8.5	gG 1 / 80	K095022	NH1GG50V80-3	gG 1 / 80 P	D095591	NH1GG50V80-4
		100	9.6	gG 1 / 100	P095026	NH1GG50V100-3	gG 1 / 100 P	E095592	NH1GG50V100-4
		125	12.5	gG 1 / 125	T095030	NH1GG50V125-3	gG 1 / 125 P	F095593	NH1GG50V125-4
		160	15	gG 1 / 160	V095031	NH1GG50V160-3	gG 1 / 160 P	G095594	NH1GG50V160-4
		200	19	gG 1 / 200	W095032	NH1GG50V200-3	gG 1 / 200 P	H095595	NH1GG50V200-4
		250	23	gG 1 / 250	Z095035	NH1GG50V250-3	gG 1 / 250 P	K095597	NH1GG50V250-4

Accessories: Neutral link Reference Number Z219304 - Reference Number A219834
Pull-out handle - PMP Reference Number P215592

General Purpose IEC Fuses



NH Fuses (Plain Blades)

gG Plastic body with/without French striker

gG 500V Size 0 and 1

from 40 to 250 A

Total Clearing I^2t

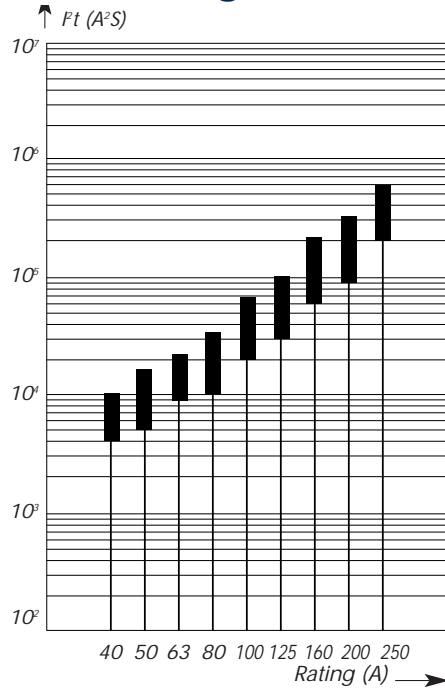

..... b: total clearing Pt @ 500 V
 █..... a: pre-arcing Pt

Current Limitation Curves

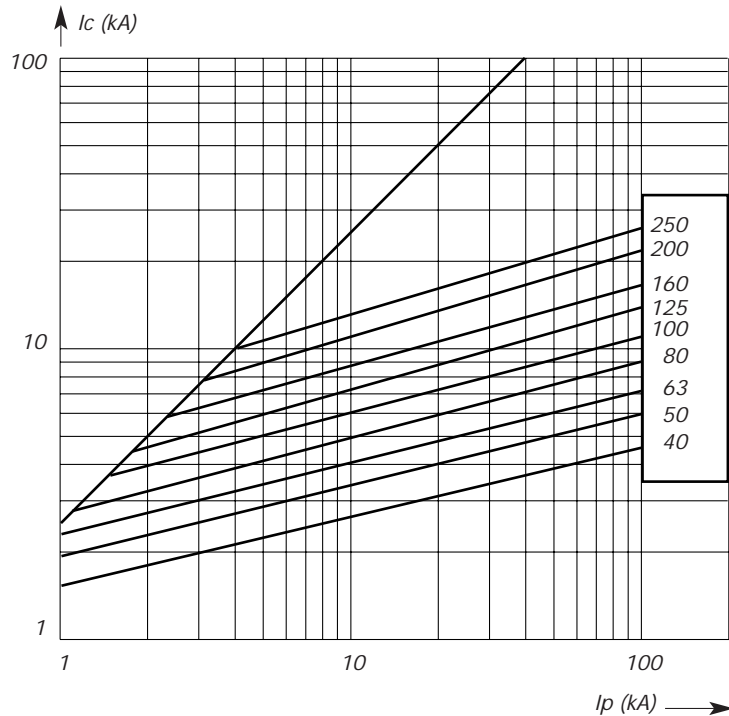

I_c = Peak let-through current
 I_p = Available fault current

Time VS. Current Characteristics

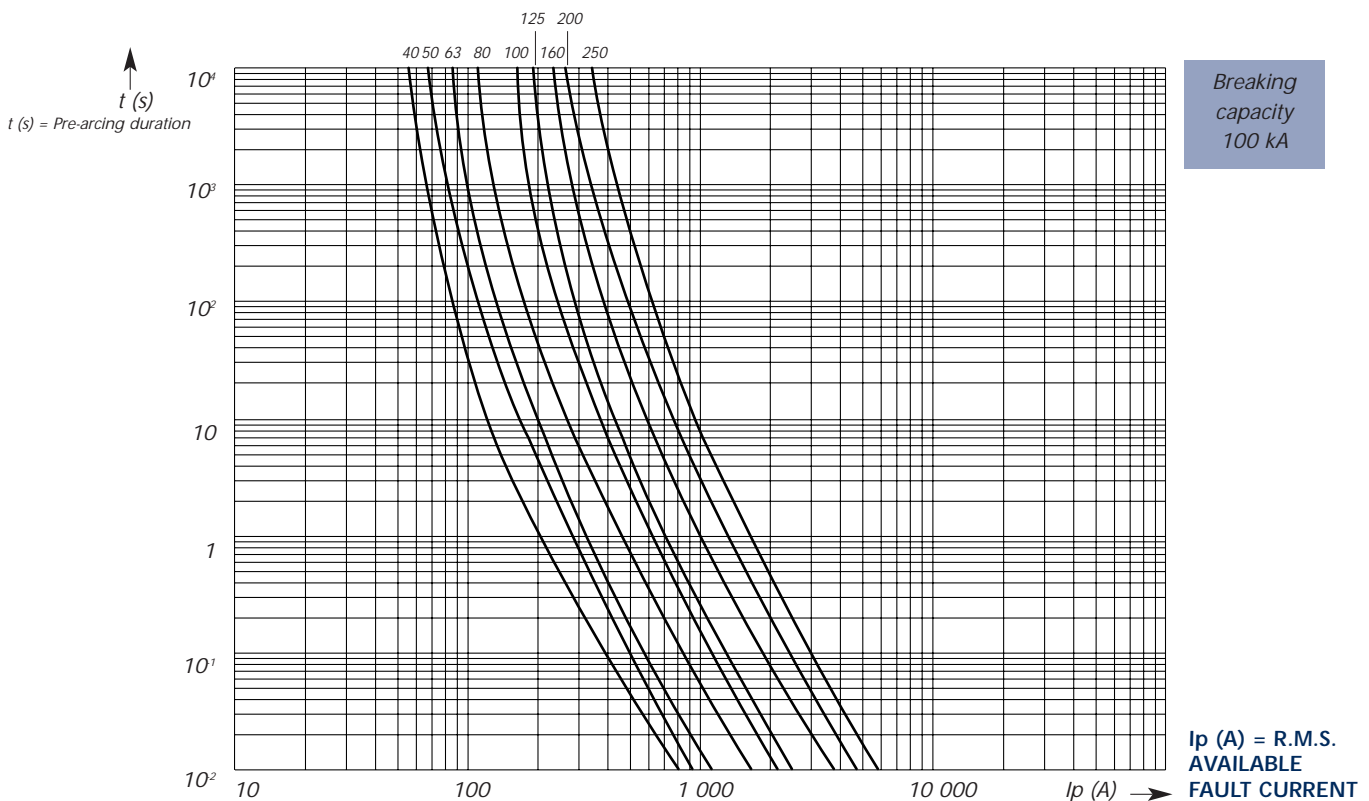

Breaking capacity
100 kA

I_p (A) = R.M.S. AVAILABLE FAULT CURRENT

General Purpose IEC Fuses



NH Fuses (Plain Blades)
Plastic body with/without French striker
gG 500V Size 2 and 3

from 125 to 630 A

- BLADE-STYLE FUSES: WITH BLOWN FUSE INDICATOR or TRIP-INDICATOR
- COMPLYING WITH IEC 269.1 and 2.1, NF EN 60269.1 & 2 NF C 63210 - 63211 AND DIN 43620
- DIMENSIONS:

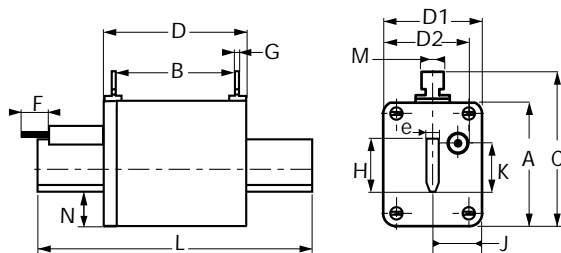

With trip-indicator

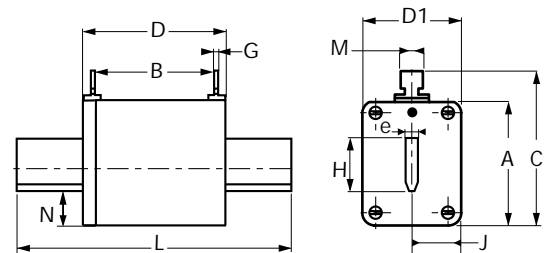

With blown fuse indicator

Size	A	B	C	D	D1	D2*	F*	G	H	J	K	L	M	N	e	Wgt.
2	60	64	72	74	50	50	14	3	28	19	14,5	150	10	14,5	6	590g
3	75	61	88	75	70	64	14	2,5	36	23	14,5	150	10	18	6	850g

* For fuses with trip-indicator

Size	Voltage rating (VAC)	Current rating I _N (A)	Watts loss (W)	With blown fuse indicator			With trip-indicator		
				Designation	Ref. Number	Catalog Number	Designation	Ref. Number	Catalog Number
2	500	125	12	gG 2 /125	H095066	NH2GG50V125-3	gG 2 /125 P	X095033	NH2GG50V125-4
		160	15	gG 2 /160	K095068	NH2GG50V160-3	gG 2 /160 P	Y095034	NH2GG50V160-4
		200	19	gG 2 /200	M095070	NH2GG50V200-3	gG 2 /200 P	A095036	NH2GG50V200-4
		250	23	gG 2 /250	G095042	NH2GG50V250-3	gG 2 /250 P	F095041	NH2GG50V250-4
		315	24	gG 2 /315	H095043	NH2GG50V315-3	gG 2 /315 P	K095045	NH2GG50V315-4
		400	33	gG 2 /400	J095044	NH2GG50V400-3	gG 2 /400 P	M095047	NH2GG50V400-4
3	500	315	24	gG 3 /315	W095170	NH3GG50V315-3	gG 3 /315 P	N095048	NH3GG50V315-4
		400	33	gG 3 /400	V095054	NH3GG50V400-3	gG 3 /400 P	P095049	NH3GG50V400-4
		500	36	gG 3 /500	W095055	NH3GG50V500-3	gG 3 /500 P	N095071	NH3GG50V500-4
		630	45	gG 3 /630	X095056	NH3GG50V630-3	gG 3 /630 P	P095072	NH3GG50V630-4

Accessories : Neutral link BS2 Reference Number J097712 - BS3 Reference Number K097713
Pull-out handle - PMP Reference Number P215592

General Purpose IEC Fuses



NH Fuses (Plain Blades)

gG Plastic body with/without French striker

gG 500V Size 2 and 3

from 125 to 630 A

Total Clearing I^2t

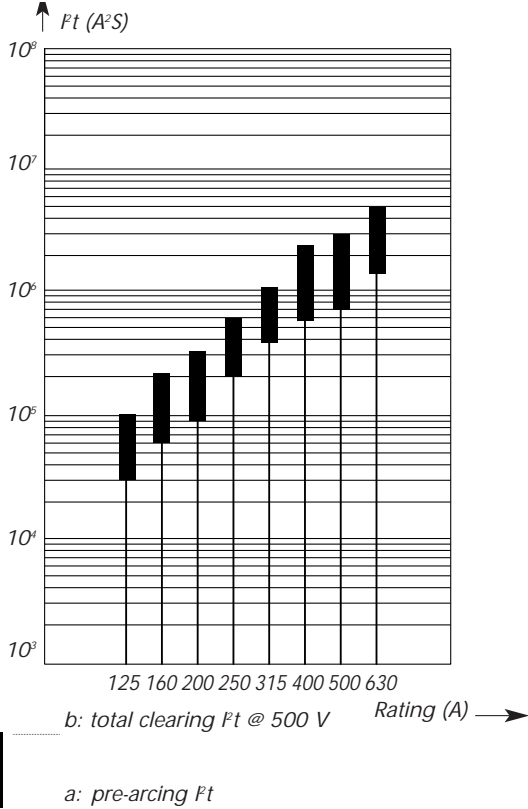

Current Limitation Curves

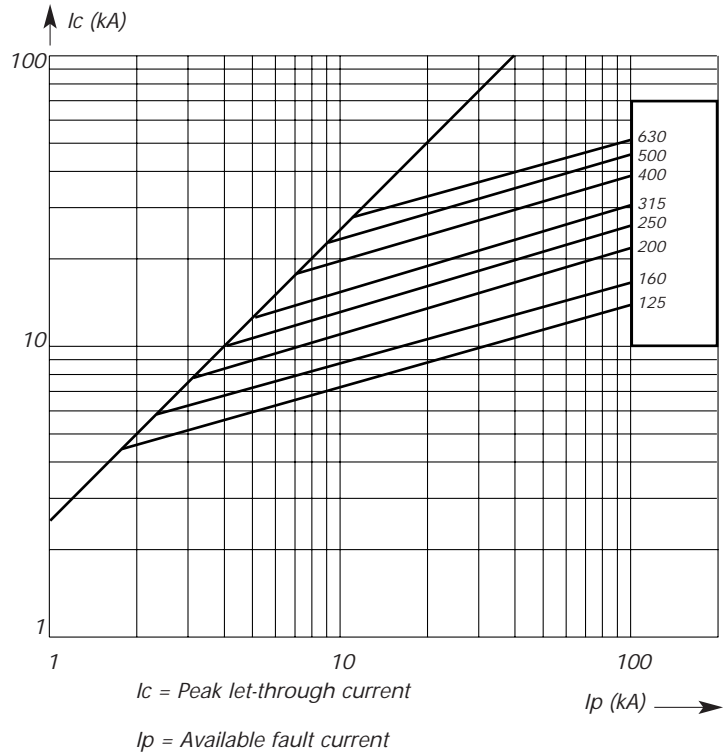

Time VS. Current Characteristics

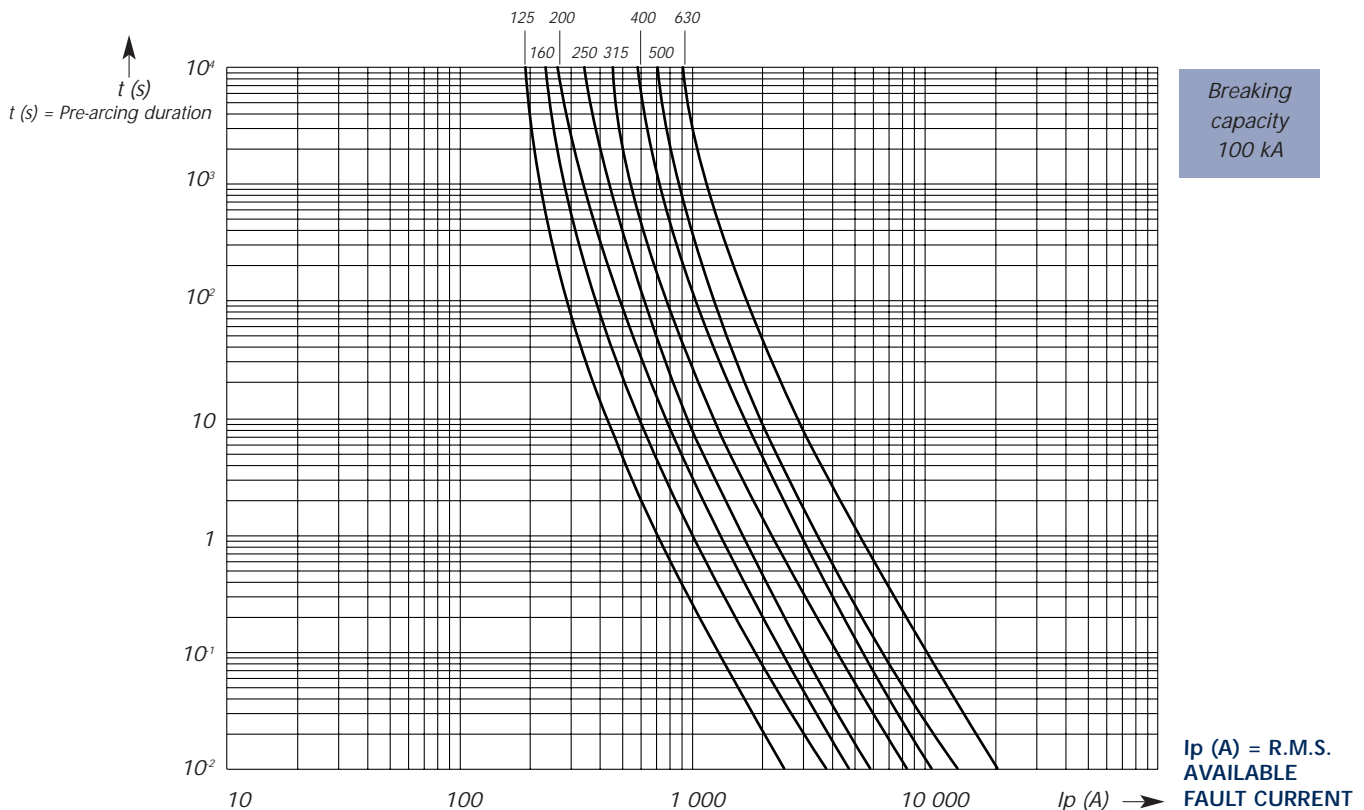

General Purpose IEC Fuses

NH Fuses (Plain Blades) gG Plastic body with/without French striker gG 500V Size 4



from 630 to 1250 A

- BLADE-STYLE FUSES: WITH BLOWN FUSE INDICATOR or TRIP-INDICATOR
- COMPLYING WITH IEC 269.1 and 2.1, NF EN 60269.1 & 2 NF C 63210 - 63211 AND DIN 43620
- DIMENSIONS:

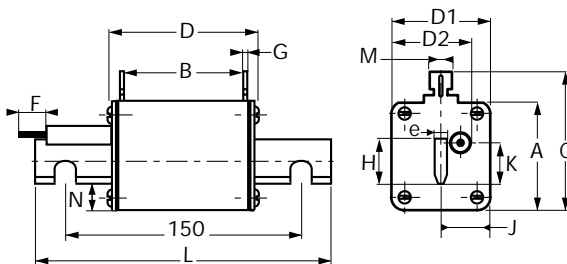

With trip-indicator

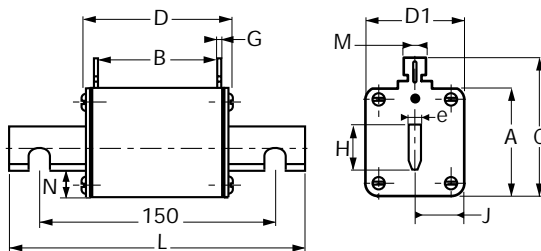

With blown fuse indicator

Size	A	B	C	D	D1	D2*	F*	G	H	J	K	L	M	N	e	Wgt.
4	107	61	119	78	90	77	14	2,5	60	27	14,5	200	10	23	8	1900g

* For fuses with trip-indicator

Size	Voltage rating (VAC)	Current rating I _N (A)	Watts loss (W)	With blown fuse indicator			With trip-indicator		
				Designation	Ref. Number	Catalog Number	Designation	Ref. Number	Catalog Number
4	500	630	45	gG 4 / 630	S098318	NH4GG50V630-3	gG 4 / 630 P	G088510	NH4GG50V630-4
		800	51	gG 4 / 800	T098319	NH4GG50V800-3	gG 4 / 800 P	J088512	NH4GG50V800-4
		1000	77	gG 4 / 1000	V098320	NH4GG50V1000-3	gG 4 / 1000 P	K088513	NH4GG50V1000-4
		1250	80	gG 4 / 1250	W098321	NH4GG50V1250-3	gG 4 / 1250 P	L088514	NH4GG50V1250-4

Accessories: Neutral link - BS4 Reference Number M097715
Pull-out handle - PMP Reference Number P215592

General Purpose IEC Fuses



NH Fuses (Plain Blades)

gG Plastic body with/without French striker

gG 500V Size 4

from 630 to 1250 A Total Clearing I²t

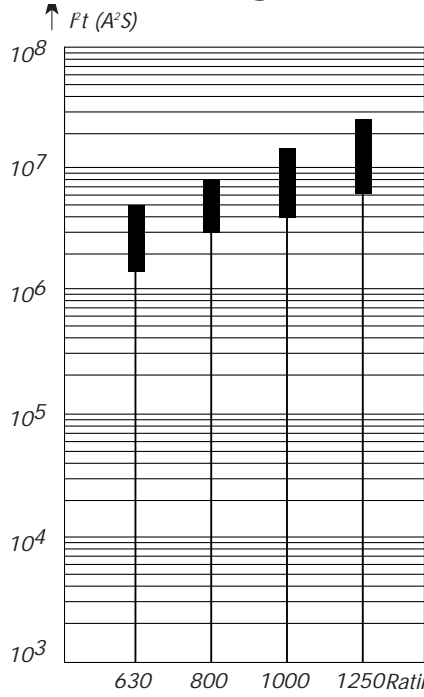

b: total clearing I²t @ 500 V
a: pre-arcing I²t

Current Limitation Curves

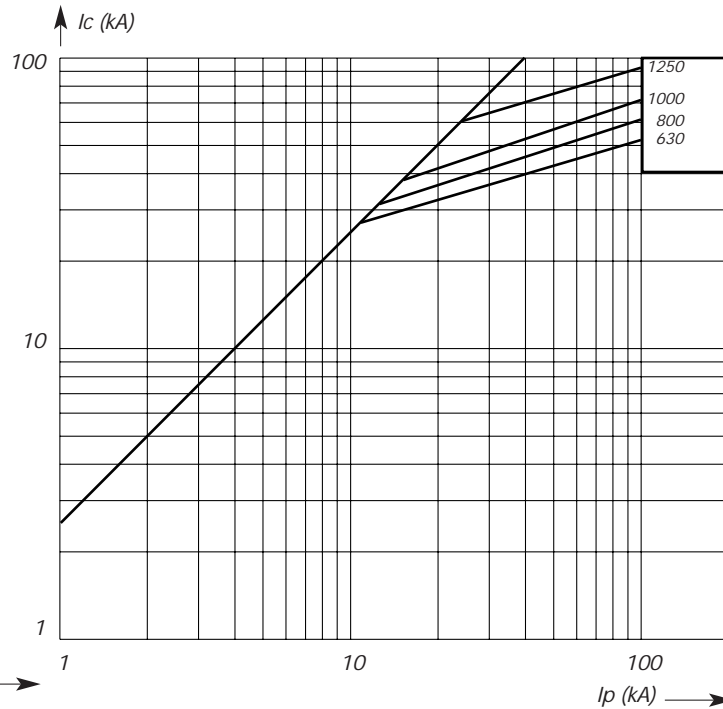

I_c = Peak let-through current
I_p = Available fault current

Time VS. Current Characteristics

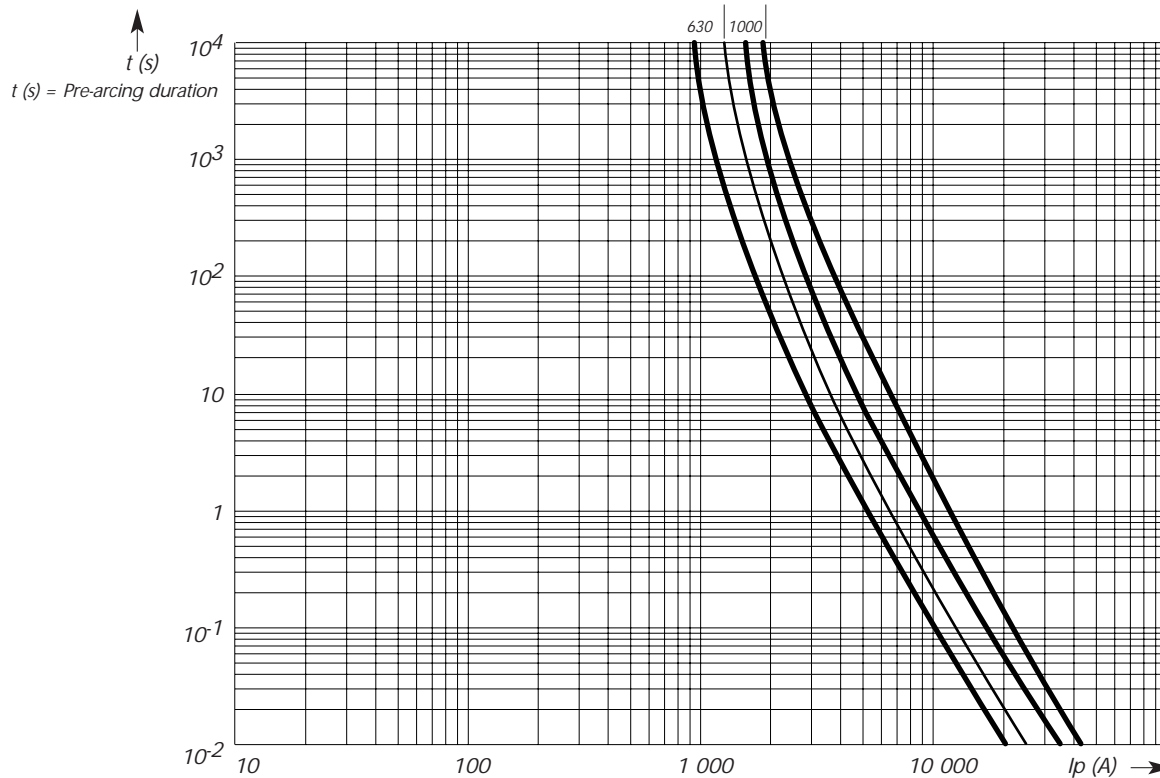

Breaking capacity
100 kA

I_p (A) = R.M.S. AVAILABLE FAULT CURRENT

General Purpose IEC Fuses

NH Fuses (Plain Blades) aM Plastic body with/without French striker aM 500V Size 00



from 16 to 125 A

- BLADE-STYLE FUSES: WITH BLOWN FUSE INDICATOR
- COMPLYING WITH IEC 269.1 and 2.1 NF EN 60269.1 & 2 NF C 63210 AND DIN 43620 STANDARDS
- DIMENSIONS:

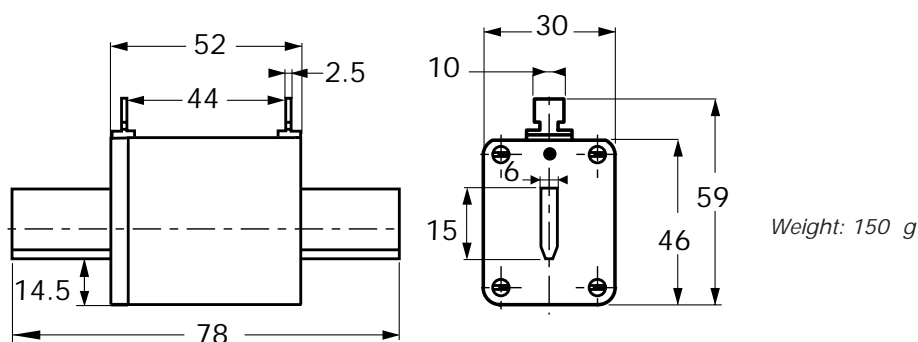

Size	Voltage rating (VAC)	Current rating I_N (A)	Watts loss (W)	With blown fuse indicator		
				Designation	Ref. Number	Catalog Number
00	500	16	0.8	aM 00 L /16	F098307	NH00AM50V16-3
		20	1.1	aM 00 L /20	G098308	NH00AM50V20-3
		25	1.3	aM 00 L /25	H098309	NH00AM50V25-3
		32	1.8	aM 00 L /32	J098310	NH00AM50V32-3
		35	2.0	aM 00 L /35	K098311	NH00AM50V35-3
		40	2.5	aM 00 L /40	L098312	NH00AM50V40-3
		50	3.0	aM 00 L /50	M098313	NH00AM50V50-3
		63	3.6	aM 00 L /63	N098314	NH00AM50V63-3
		80	5.2	aM 00 L /80	P098315	NH00AM50V80-3
	100	6.0	aM 00 L /100	Q098316	NH00AM50V100-3	
400	125	7.0	aM 00 L /125	R098317	NH00AM40V125-3	

Accessories: Neutral link BS00 - Reference Number F097709
Pull-out handle - PMP - Reference Number P215592

General Purpose IEC Fuses



NH Fuses (Plain Blades)

aM Plastic body with/without French striker

aM 500V Size 00

from 16 to 125 A
Total Clearing I^2t

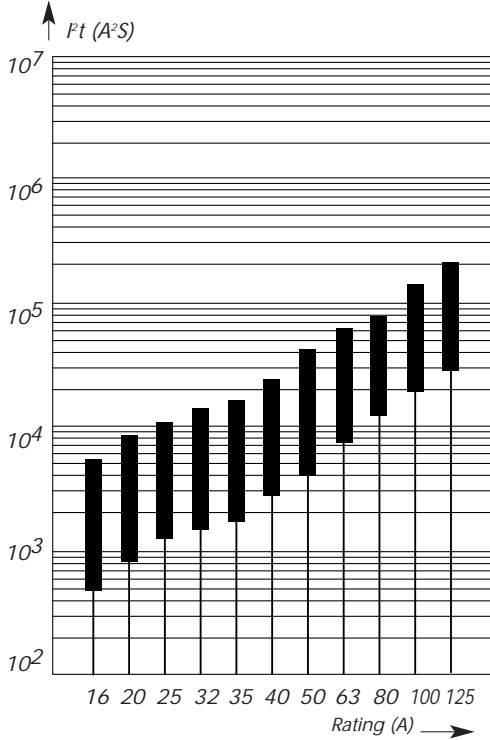

b: total clearing I^2t @ 500 V

a: pre-arcing I^2t

Current Limitation Curves

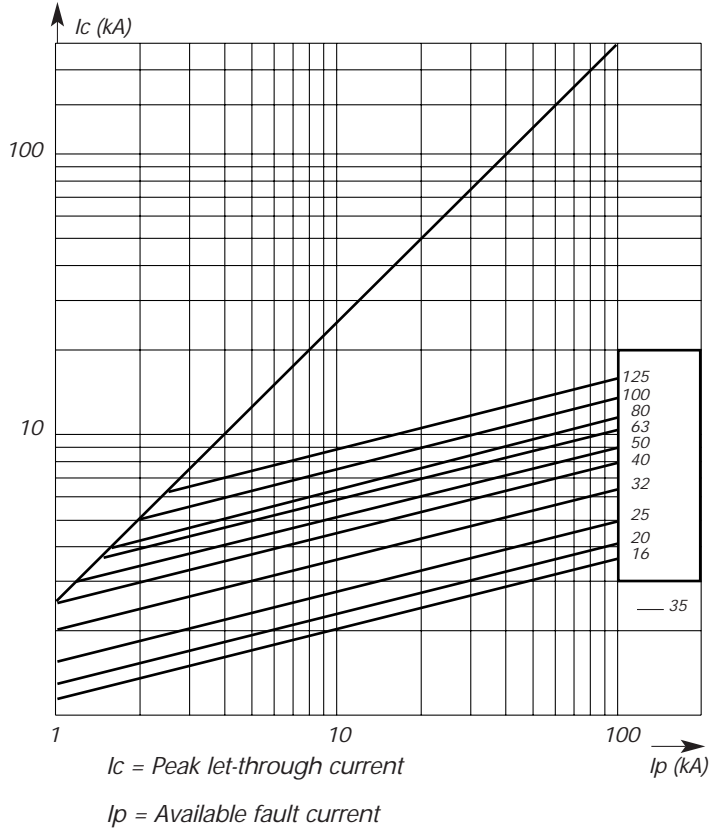

Time VS. Current Characteristics

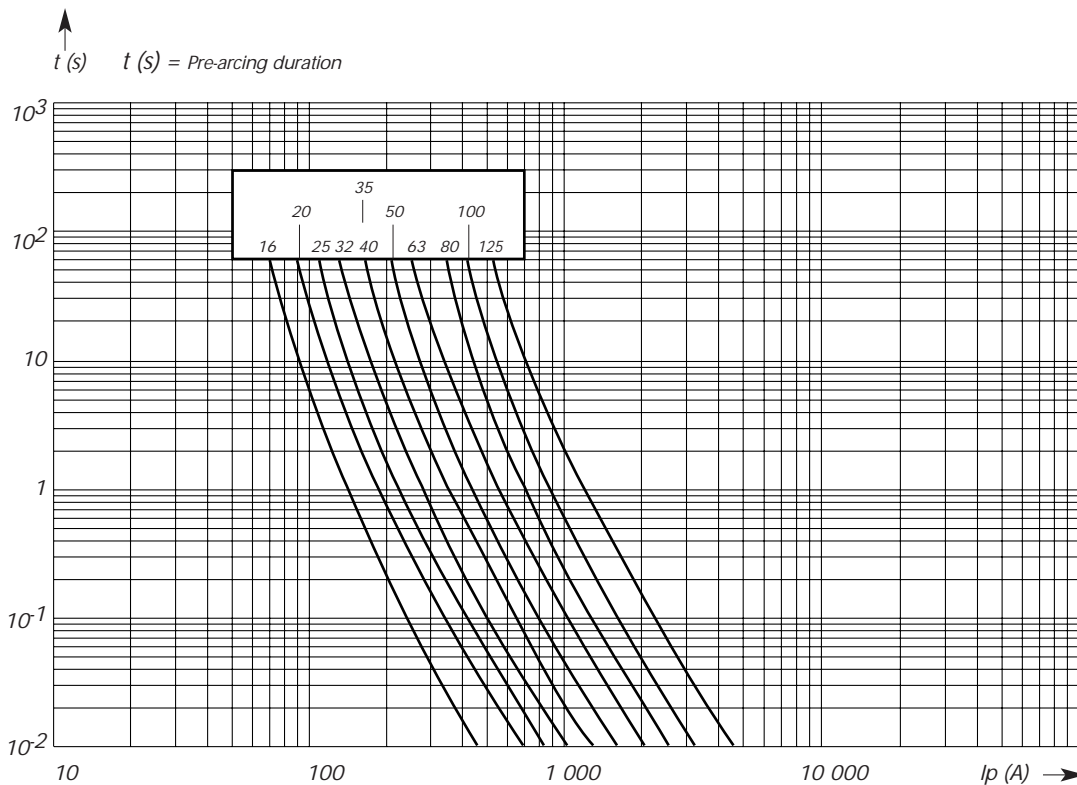

Breaking capacity
100 kA

I_p (A) = R.M.S. AVAILABLE FAULT CURRENT

General Purpose IEC Fuses



NH Fuses (Plain Blades)
aM Plastic body with/without French striker
aM 500V Size 0 and 1

from 40 to 315 A

- BLADE-STYLE FUSES: WITH BLOWN FUSE INDICATOR
- COMPLYING WITH IEC 269.1 and 2.1 NF EN 60269.1 & 2 NF C 63210 AND DIN 43620 STANDARDS
- DIMENSIONS:

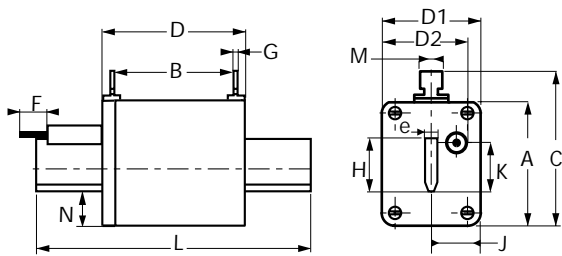

With trip-indicator

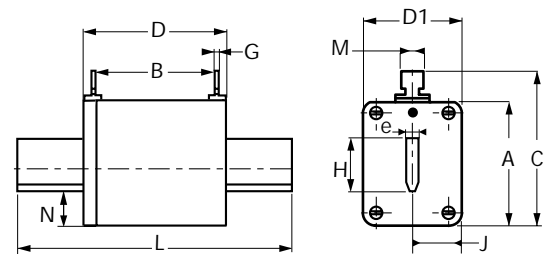

With blown fuse indicator

Size	A	B	C	D	D1	D2*	F*	G	H	J	K	L	M	N	e	Wgt.
0	46	62	59	67	36	39	14	2,5	15	14,5	14,5	125	10	14,5	6	230g
1	52	64	64	74	47	47	14	3	21	16	14,5	135	10	14,5	6	400g

* For fuses with trip-indicator

Size	Voltage rating (VAC)	Current rating I _N (A)	Watts loss (W)	With blown fuse indicator			With trip-indicator		
				Designation	Ref. Number	Catalog Number	Designation	Ref. Number	Catalog Number
0	500	40	2,7	aM 0 / 40	K095114	NH0AM50V40-3	aM 0 / 40 P	N095232	NH0AM50V40-4
		50	3,2	aM 0 / 50	L095115	NH0AM50V50-3	aM 0 / 50 P	R095235	NH0AM50V50-4
		63	3,9	aM 0 / 63	M095116	NH0AM50V63-3	aM 0 / 63 P	X095240	NH0AM50V63-4
		80	5,5	aM 0 / 80	P095118	NH0AM50V80-3	aM 0 / 80 P	Z095242	NH0AM50V80-4
		100	6,5	aM 0 / 100	R095120	NH0AM50V100-3	aM 0 / 100 P	A095243	NH0AM50V100-4
		125	8,5	aM 0 / 125	T095122	NH0AM50V125-3	aM 0 / 125 P	B095244	NH0AM50V125-4
		160	11,5	aM 0 / 160	Y095126	NH0AM50V160-3	aM 0 / 160 P	M095254	NH0AM50V160-4
1	500	200	13,5	aM 0 / 200	R088519	NH0AM50V200-3	aM 0 / 200 P	F088509	NH0AM50V200-4
		80	5,5	aM 1 / 80	R095166	NH1AM50V80-3	aM 1 / 80 P	P095256	NH1AM50V80-4
		100	6,5	aM 1 / 100	T095168	NH1AM50V100-3	aM 1 / 100 P	E095270	NH1AM50V100-4
		125	8,5	aM 1 / 125	C095130	NH1AM50V125-3	aM 1 / 125 P	V095330	NH1AM50V125-4
		160	11,5	aM 1 / 160	D095131	NH1AM50V160-3	aM 1 / 160 P	W095331	NH1AM50V160-4
		200	13,5	aM 1 / 200	E095132	NH1AM50V200-3	aM 1 / 200 P	X095332	NH1AM50V200-4
	500	250	17	aM 1 / 250	H095135	NH1AM50V250-3	aM 1 / 250 P	A095335	NH1AM50V250-4
		315	24	aM 1 / 315	T088521	NH1AM50V315-3	aM 1 / 315 P	B095336	NH1AM50V315-4

Accessories: Neutral link BSO Reference Number G097710 - BS1 Reference Number H097711
 Pull-out handle - PMP Reference Number P215592

General Purpose IEC Fuses



NH Fuses (Plain Blades)

aM Plastic body with/without French striker

aM 500V Size 0 and 1

from 40 to 315 A

Total Clearing I^2t

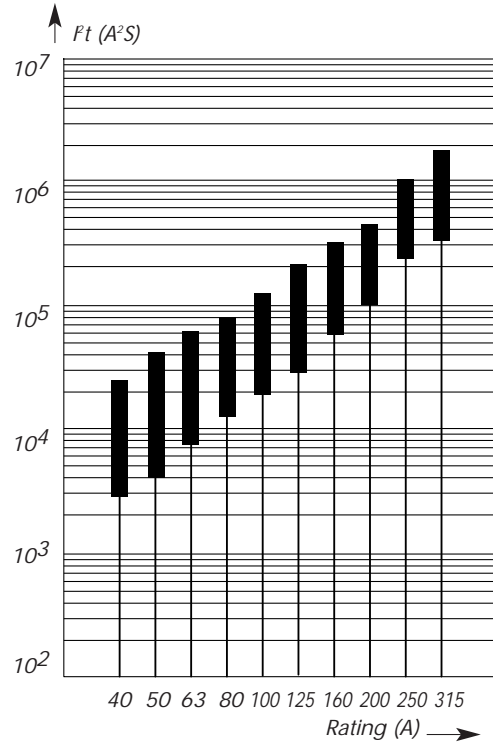

b: total clearing I^2t @ 500 V

a: pre-arcing I^2t

Current Limitation Curves

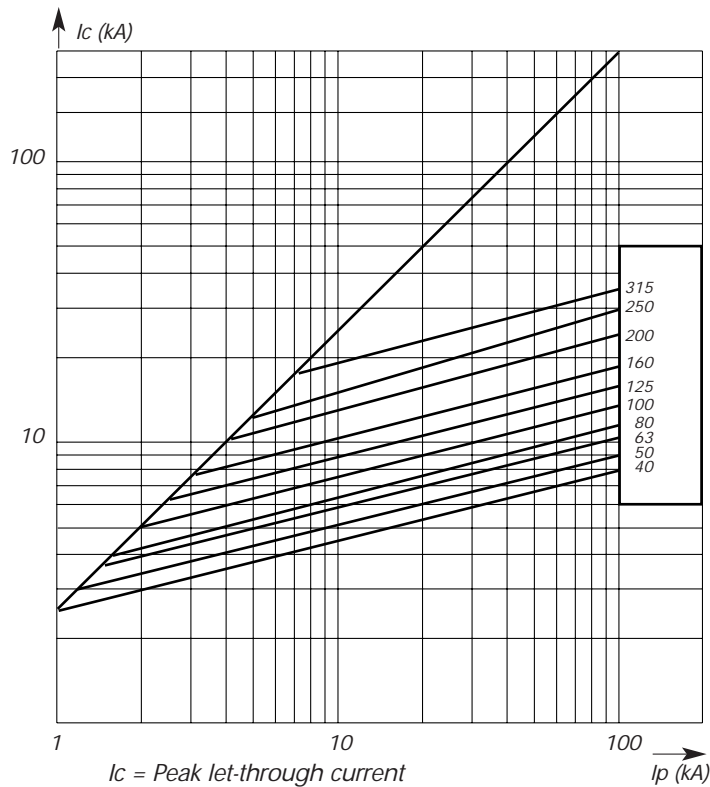

I_c = Peak let-through current

I_p = Available fault current

Time VS. Current Characteristics

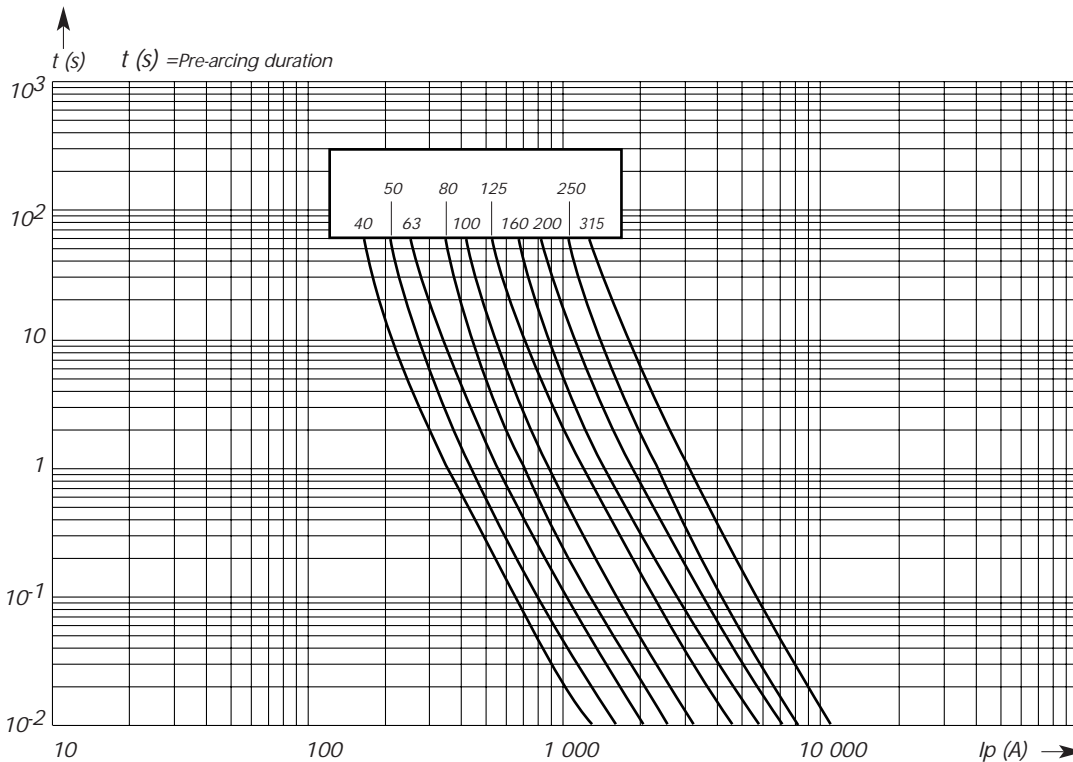

Breaking capacity
100 kA

I_p (A) = R.M.S. AVAILABLE FAULT CURRENT

General Purpose IEC Fuses



NH Fuses (Plain Blades)
aM Plastic body with/without French striker
aM 500V Size 2 and 3

from 125 to 630 A

- BLADE-STYLE FUSES: WITH BLOWN FUSE INDICATOR OR TRIP-INDICATOR
- COMPLYING WITH IEC 269.1 AND 2.1, NF EN 60269.1 & 2 NF C 63210 - 63211 AND DIN 43620
- DIMENSIONS:

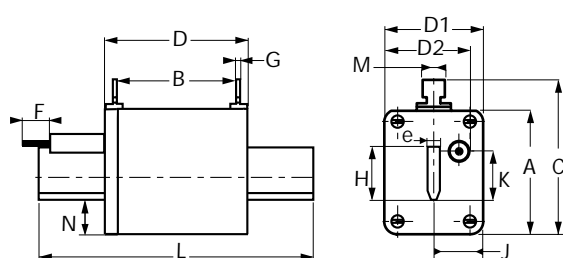

With trip-indicator

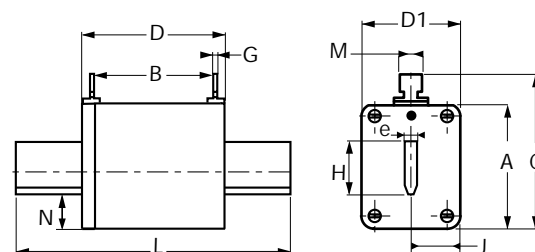

With blown fuse indicator

Size	A	B	C	D	D1	D2*	F*	G	H	J	K	L	M	N	e	Wgt.
2	60	64	72	74	50	50	14	3	28	19	14,5	150	10	14,5	6	590g
3	75	61	88	75	70	64	14	2,5	36	23	14,5	150	10	18	6	850g

* For fuses with trip-indicator

Size	Voltage rating (VAC)	Current rating I _N (A)	Watts loss (W)	With blown fuse indicator			With trip-indicator		
				Designation	Ref. Number	Catalog Number	Designation	Ref. Number	Catalog Number
2	500	125	8,5	aM 2 /125	P095210	NH2AM50V125-3	aM 2 /125 P	Z095196	NH2AM50V125-4
		160	11,5	aM 2 /160	Q095211	NH2AM50V160-3	aM 2 /160 P	S095213	NH2AM50V160-4
		200	13,5	aM 2 /200	R095212	NH2AM50V200-3	aM 2 /200 P	F095340	NH2AM50V200-4
		250	17	aM 2 /250	Q095142	NH2AM50V250-3	aM 2 /250 P	H095342	NH2AM50V250-4
		315	24	aM 2 /315	R095143	NH2AM50V315-3	aM 2 /315 P	J095343	NH2AM50V315-4
		400	28	aM 2 /400	S095144	NH2AM50V400-3	aM 2 /400 P	K095344	NH2AM50V400-4
3	500	500	34	aM 2 /500	W088523	NH2AM50V500-3	aM 2 /500 P	L095345	NH2AM50V500-4
		315	24	aM 3 /315	J095182	NH3AM50V315-3	aM 3 /315 P	Q095073	NH3AM50V315-4
		400	28	aM 3 /400	D095154	NH3AM50V400-3	aM 3 /400 P	W095354	NH3AM50V400-4
		500	34	aM 3 /500	E095155	NH3AM50V500-3	aM 3 /500 P	X095355	NH3AM50V500-4
		630	41	aM 3 /630	F095156	NH3AM50V630-3	aM 3 /630 P	Y095356	NH3AM50V630-4

Accessories: Neutral link BS2 Reference Number J097712 - BS3 Reference Number K097713
 Pull-out handle - PMP Reference Number P215592

General Purpose IEC Fuses



NH Fuses (Plain Blades)

aM Plastic body with/without French striker

aM 500V Size 2 and 3

from 125 to 630 A

Total Clearing I^2t

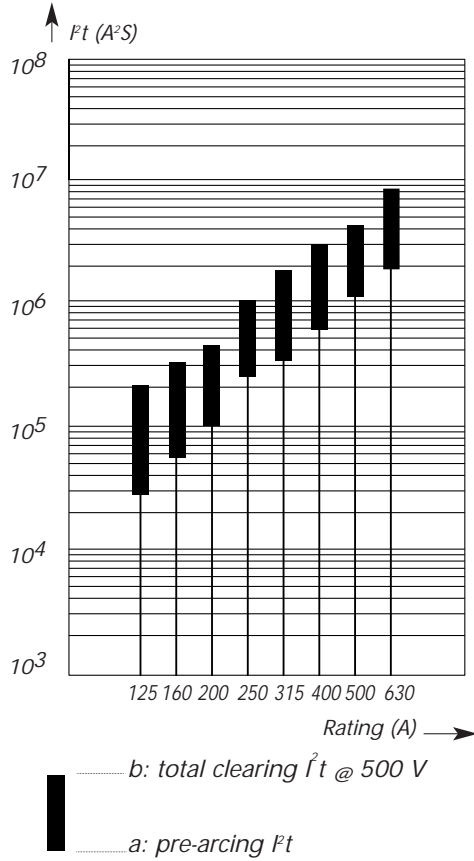

Current Limitation Curves

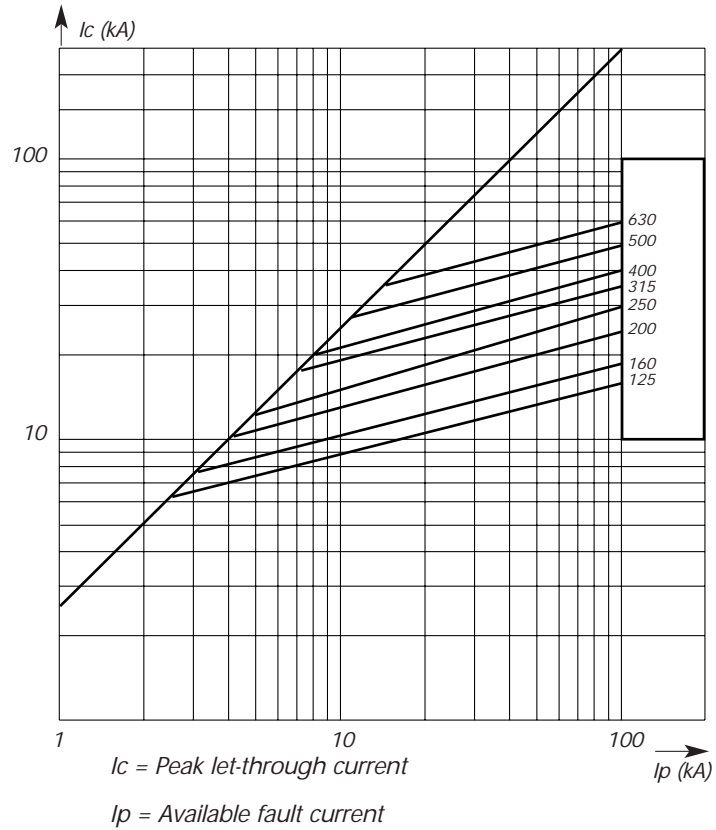

Time VS. Current Characteristics

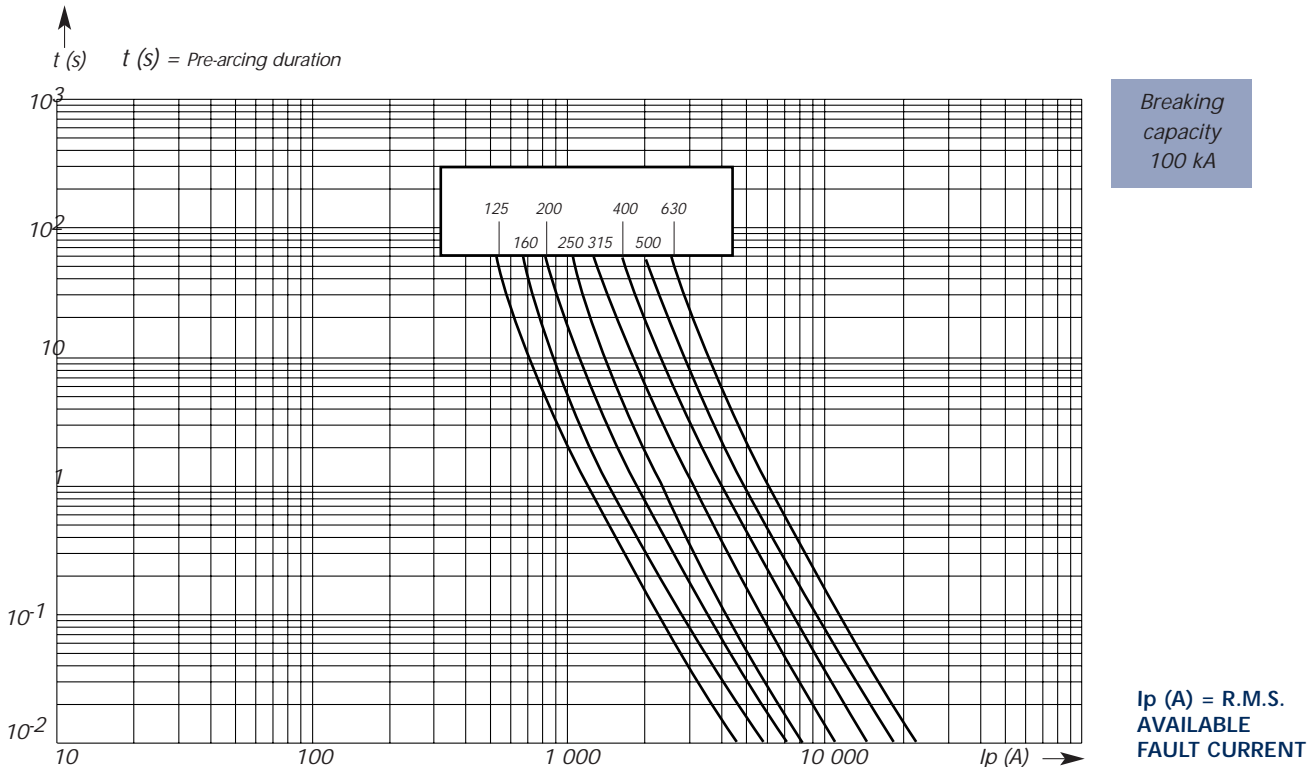

General Purpose IEC Fuses

NH Fuses (Plain Blades) aM Plastic body with/without French striker aM 500V Size 4



from 630 to 1250 A

- BLADE-STYLE FUSES: WITH BLOWN FUSE INDICATOR OR TRIP-INDICATOR
- COMPLYING WITH IEC 269.1 AND 2.1, NF EN 60269.1 & 2 NF C 63210 - 63211 AND DIN 43620
- DIMENSIONS:

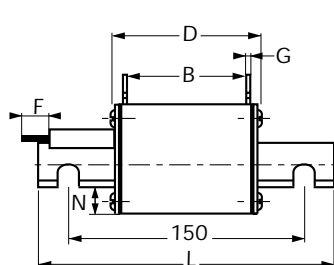

With trip-indicator

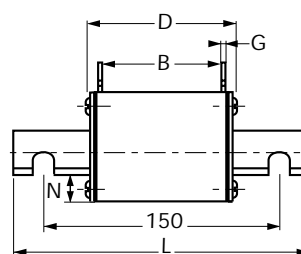
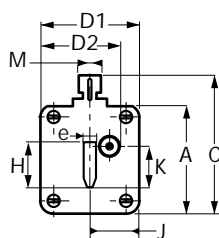

With blown fuse indicator

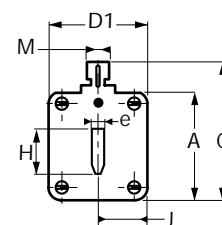

Size	A	B	C	D	D1	D2*	F*	G	H	J	K	L	M	N	e	Wgt.
4	107	61	119	78	90	77	14	2,5	60	27	14,5	200	10	23	8	1900g

* For fuses with trip-indicator

Size	Voltage rating (VAC)	Current rating I _N (A)	Watts loss (W)	With blown fuse indicator			With trip-indicator		
				Designation	Ref. Number	Catalog Number	Designation	Ref. Number	Catalog Number
4	500	630	41	aM 4 /630	X098322	NH4AM50V630-3	aM 4 /630 P	M088515	NH4AM50V630-4
		800	49	aM 4 /800	A098325	NH4AM50V800-3	aM 4 /800 P	N088516	NH4AM50V800-4
		1000	70	aM 4 /1000	B098326	NH4AM50V1000-3	aM 4 /1000 P	P088517	NH4AM50V1000-4
	400	1250	75	aM 4 /1250	C098327	NH4AM40V1250-3	aM 4 /1250 P	Q088518	NH4AM40V1250-4

Accessories: Neutral link - BS4 Reference Number M097715
Pull-out handle - PMP Reference Number P215592

General Purpose IEC Fuses



NH Fuses (Plain Blades)

aM Plastic body with/without French striker

aM 500V Size 4

from 630 to 1250 A

Total Clearing I^2t

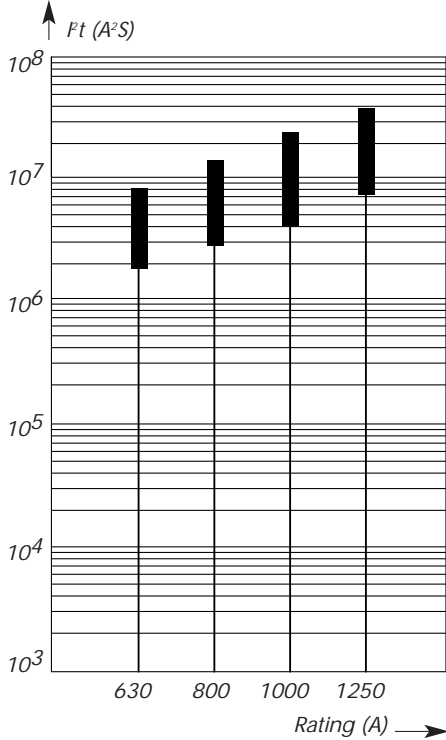

b: total clearing I^2t @ 500 V

a: pre-arcing I^2t

Current Limitation Curves

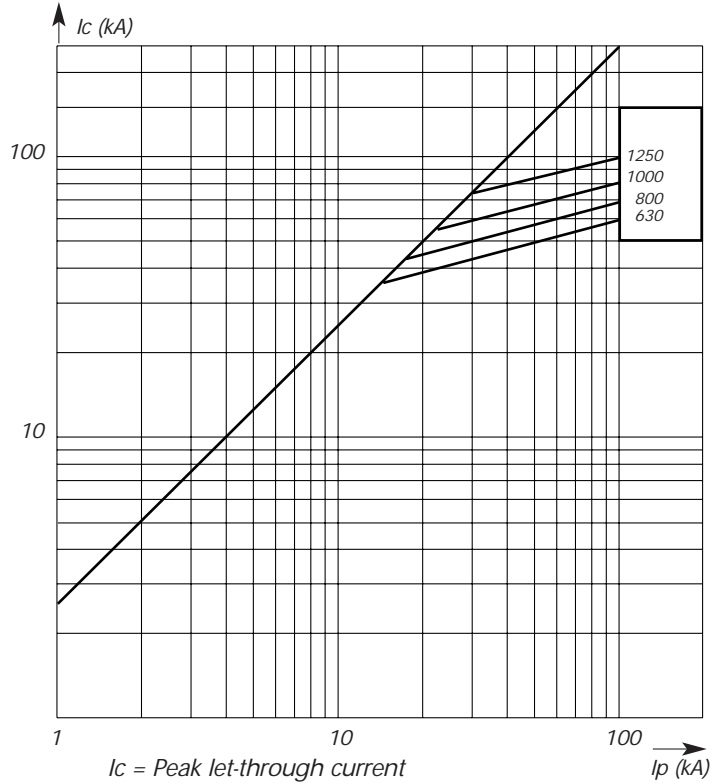

I_c = Peak let-through current

I_p = Available fault current

Time VS. Current Characteristics

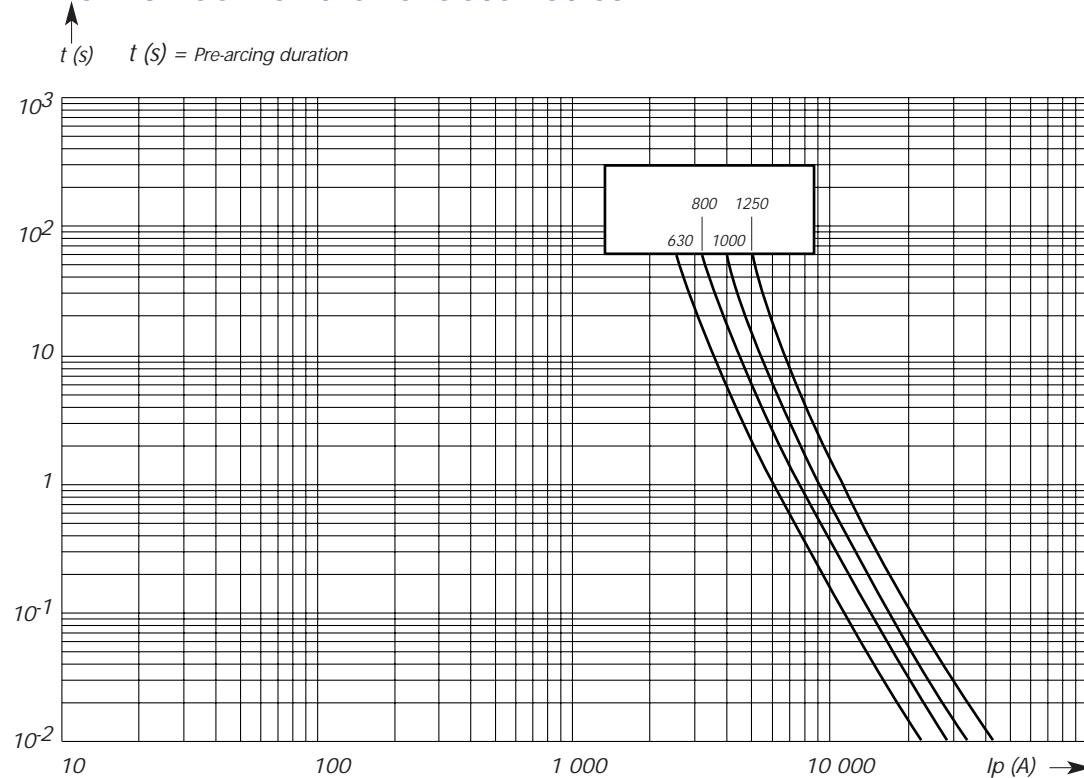

Breaking capacity
100 kA

I_p (A) = R.M.S. AVAILABLE FAULT CURRENT

General Purpose Fuses IEC

Masterfuse gG 690V



Highlights

- High ratings 1250 to 2500 A
- gG operating fuse for 690V AC Nominal
- Conformity with IEC 60269 1 and 2
- Dimensional according section V on IEC 60269-2-1
- Breaking capacity 690V 160 KA – 50Hz

Applications

- General protection on Low Voltage Panel
- High power protection on 690V AC Voltage
- Back up for circuit breaker
- Blade fuses for power bus bar assembly
- Disconnecter, Switch and/or Circuit Breaker isolation

Main characteristics

Rated current	Size (Ø in mm)	Melting I ² t (KA ² s)	Total I ² t at 690V (KA ² s)	Power losses at I _n (W)	Breaking capacity	Ref.Number	Catalog number
1250 A	76	1590	8200	78	160 KA at 690V AC	E 302753	MF76GG69V1250
1600 A	89	2500	13000	111		F 302754	MF89GG69V1600
2000 A	114	4800	25000	128		G 302755	MF114GG69V2000
2500 A	127	7000	36000	175		H 302756	MF127GG69V2500

Pack: 1 piece

For ratings 3200A(Ø 146mm) – 4000A (Ø 160mm) – 4800 A (Ø 181mm) consults us

Electrical characteristics

I²t vs rated current and applied voltage characteristics

Prearcing and clearing I²t(kA²s)

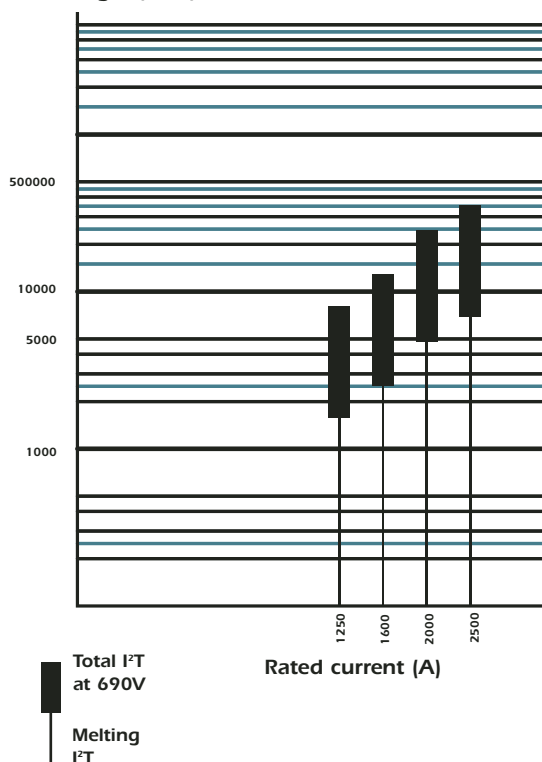

Peak let-thru current characteristics

Maximum peak let-thru current I_m (A)

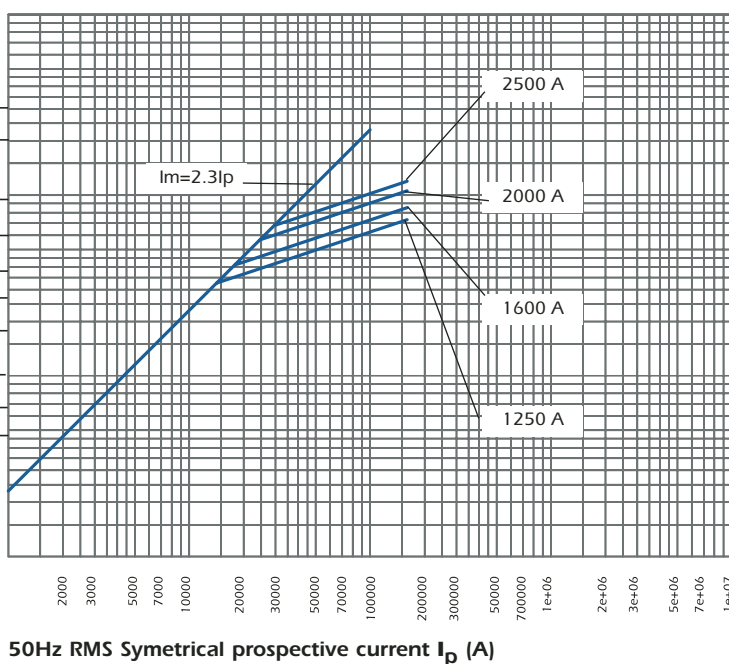

General Purpose Fuses IEC

Masterfuse gG 690V

Time current characteristics

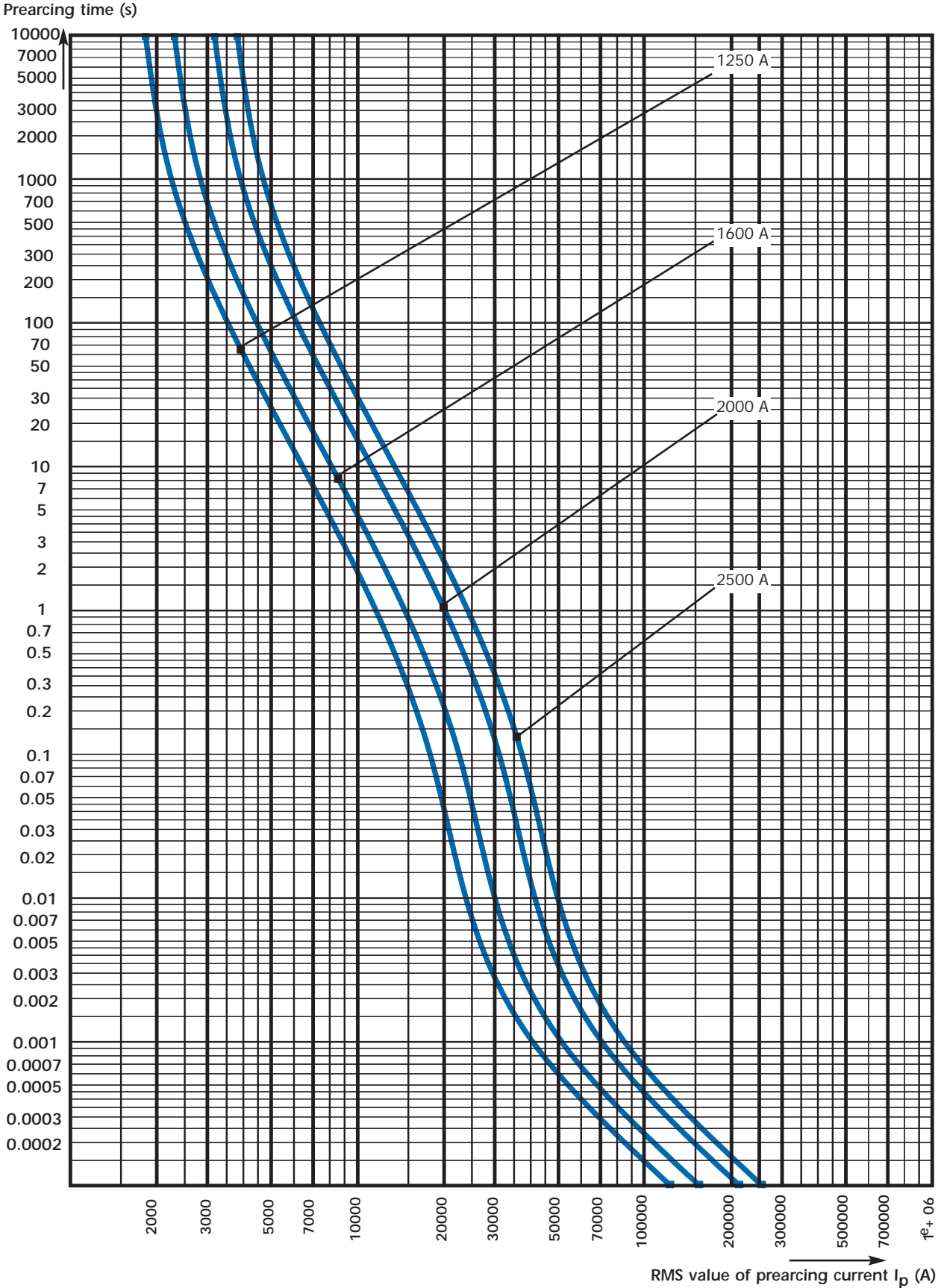

Dimensions

690 VgG 1250 A

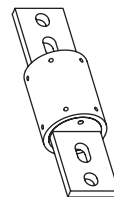
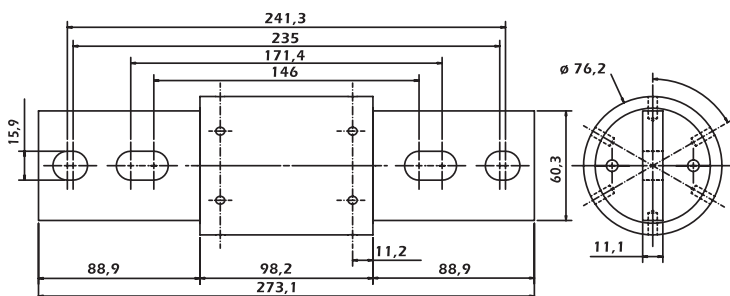

690 VgG 1600 A

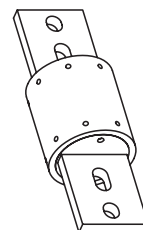
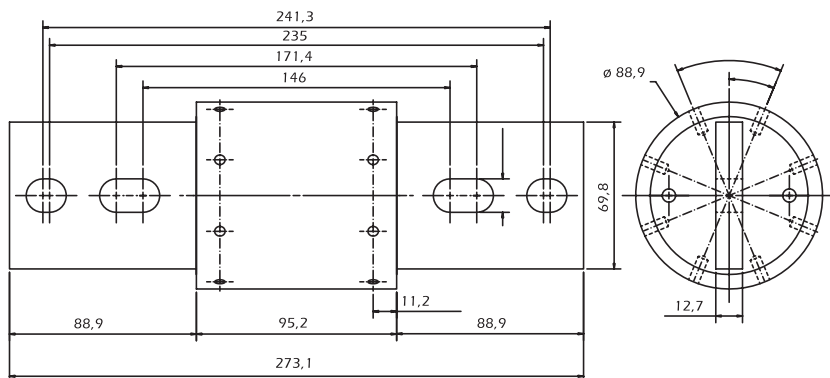

690 VgG 2000 A

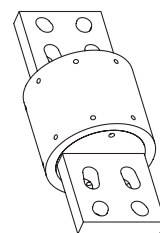
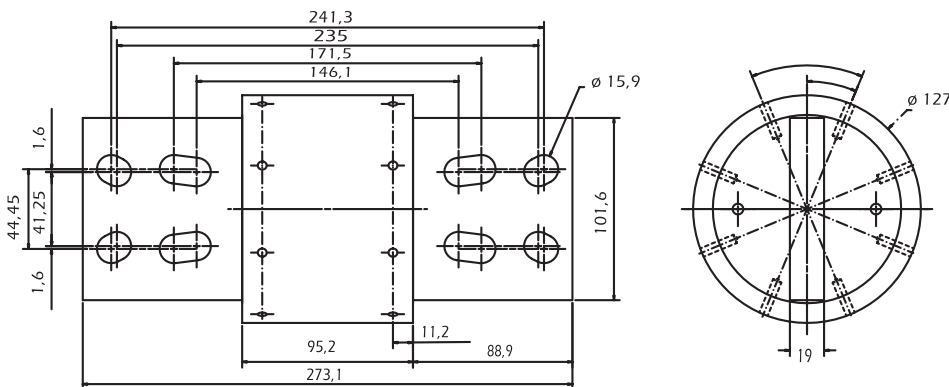

690 VgG 2500 A

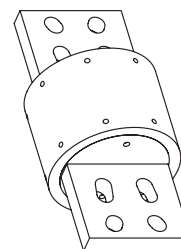
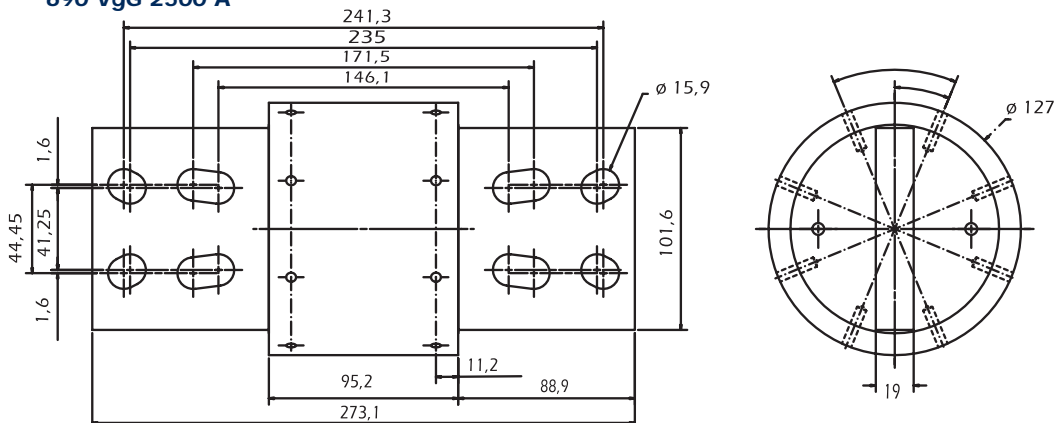



General Purpose IEC Fuses

DIN Fuses
D0-type
NEOZED



D0 Fuse System

2–100 A, 400 (440) VAC, 250 VDC

Line protection fuses - gG

Motor protection fuses - aM

IEC 269-3-1

DIN VDE 0636 Part 41

DIN VDE 0636 Part 301



Germany



Austria



Denmark



Norway

Dimensions are stipulated in the following regulations:

DIN 49522 D0 Fuse-links

DIN 49523 D0 Gauge rings

DIN 49524 D0 Fuse bases

Structure of NEOZED fuse system

The NEOZED system, similar to the D-system, consists of a fuse base, gauge-ring, fuse link and screw cap. It is dimensioned for nominal voltages of 440VAC 400 VAC and 250 VDC. The system guarantees that from 6 A onwards rated current will not be confused from current stage to current stage. This is ensured by staging the diameter of the fuse links base current in connection with gauge diameters determined accordingly.

General Purpose IEC Fuses



DIN Fuses D0-type NEOZED



D0 Fuse System

NEOZED Fuse-links 2–100 A gG

400 VAC, 250 VDC

Size	Rated in Current (A)	Gauge Color	Previous Reference	Reference Number	Pack	Catalog Number
D01	2	pink	01700.002000	T214676	50	
	4	brown	01700.004000	W200809	50	
	6	green	01700.006000	B215695	50	
	10	red	01700.010000	W211090	50	
	13	black	01700.013000*	C201206*	50	
	16	grey	01700.016000	R223023	50	
D02	20	blue	01701.020000	B217742	50	
	25	yellow	01701.025000	W213160	50	
	35	black	01701.035000	R219826	50	
	50	white	01701.050000	D215191	50	
	63	copper	01701.063000	C201873	50	
D03	80	silver	01702.080000	L216716	10	
	100	red	01702.100000	N212647	10	

*No VDE, ÖVE testing mark



Back-up fuse in operating class gG

Rated in Current (A)	20 A	25 A	35 A	50 A	63 A	80 A
20 A aM	600	300	200	<100	<100	<100
25 A aM	-	1500	700	100	<100	<100
35 A aM	-	-	1000	300	200	<100

NEOZED Fuse-links 20–35 A aM

400 VAC / 440 VAC

Size	Rated in Current (A)	Gauge Color	Previous Reference	Reference Number	Pack	Catalog Number
D02	20	blue	01701.020500*	H211607*	10	
	25	yellow	01701.025500*	F212640*	10	
	35	black	01701.035500*	J213655*	10	

*No VDE, ÖVE testing mark

Dimensions see following pages





General Purpose IEC Fuses

DIN Fuses
D0-type
NEOZED



D0 Fuse System

INNOZED Neozed-Sicherungssockel

für Schnappbefestigung mit Abdeckung, 400VAC



Größe	Bemessungsstrom in A	Polzahl	Referenz Nummer	Gewich in g/Stück	VE	Artikel -Gruppe
D01	16	1	2724.	75	12	42
D01	16	3	2734.	223	4	42
D02	63	1	2725.	77	12	42
D02	63	3	2735.	229	4	42

INNOZED Neozed-Sicherungssockel

für Schnappbefestigung ohne Abdeckung, 400VAC



Größe	Bemessungsstrom in A	Polzahl	Referenz Nummer	Gewich in g/Stück	VE	Artikel -Gruppe
D01	16	1	2724.1	70	12	42
D01	16	3	2734.1	210	4	42
D02	63	1	2725.1	72	12	42
D02	63	3	2735.1	217	4	42

Abdeckung für INNOZED



Größe	Bemessungsstrom in A	Polzahl	Referenz Nummer	Gewich in g/Stück	VE	Artikel -Gruppe
D01/ D02		1	2718.	5	24	42
D01/ D02		3	2732.	12	12	42

General Purpose IEC Fuses



DIN Fuses D0-type NEOZED

D0 Fuse System NEOZED Screw cap - plastic

400 VAC / 440 VAC

Size	Rated in Current (A)	Cap Thread	Previous Reference	Reference Number	Pack	Catalog Number
with testing hole						
D01	16	E 14	01714.000200	E212501	20	
D02	63	E 18	01715.000200	P211981	20	
for D01 fuse links with adapter spring						
D02		E 18	01715.890200	M214026	20	
with sealable hole and testing hole						
D01	16	E 14	11714.000220	R214536	20	
D02	63	E 18	11715.000220	S214537	20	
without testing hole						
D02	63	E 18	01715.000000	L206435	20	



NEOZED Screw cap - porcelain

400 VAC / 440 VAC

Size	Rated in Current (A)	Cap Thread	Previous Reference	Reference Number	Pack	Catalog Number
with testing hole						
D01	16	E	14 01710.000200	H201211	20	
D02	63	E 18	01711.000200	T215044	20	
without testing hole						
D03 100	M30 x 2		01712.000200	V215045	20	

Dimensions see following pages



NEOZED Gauge rings

Size	Rated in Current (A)	Cap Thread	Previous Reference	Reference Number	Pack	Catalog Number
D01	2	pink	01705.002000	J216576	50	
	4	brown	01705.004000	J219681	50	
	6	green	01705.006000	P206438	50	
	10	red	01705.010000	M213014	50	
D02	2	pink	01706.002000*	K216577*	50	
	4	brown	01706.004000*	S222127*	50	
	6	green	01706.006000*	R211983*	50	
	10	red	01706.010000*	H216069*	50	
	16	grey	01706.016000*	Q218629*	50	
	20	blue	01706.020000	S200668	50	
	25	yellow	01706.025000	R213524	50	
	35	black	01706.035000	J216070	50	
	50	white	01706.050000	R218630	50	
D03	80	silver	01707.080000	T200669	25	

*For use of D01 fuse-links in D02 fuse-bases

Dimensions see following pages





General Purpose IEC Fuses

DIN Fuses
D0-type
NEOZED

D0 Fuse System

NEOZED Insulating covers

single pole for ceramic fuse bases:



3 pole:

	Previous Reference	Reference Number	Pack	Catalog Number
for type D01/D02				
with 1-side marking area	01718.008000	M222881	50	
with marking area	01718.700000	V200670	50	
for type D03				
without marking area	01728.000000	V211986	20	
for type D01/D02				
cover - cap	01721.030000	X201730	20	
for type D01/D02				
with marking area	01732.700000	M216579	20	

Dimensions see following pages

NEOZED Fuse bases

for screw mounting without shock-proof protection-cover, 400 VAC



Size	Rated in Current (A)	Pole	Max. cross sect. mm ²	Previous Reference	Reference Number	Pack	Catalog Number
D01	16	1 (1*)	4	01720.100000	Z216061	20	
D02	63	1 (2*)	25	01721.200000	M214532	20	
D02	63	1 (4*)	25	01721.400000	F213008	20	
D03	100	1 (4*)	50	01722.400000	J213011	10	
D01	16	3 (1*)	4	01730.100000	K200661	5	
D02	63	3 (2*)	25	01731.200000	F216573	5	
D02	63	3 (4*)	25	01731.400000	K206365	5	

NEOZED Fuse bases

for snap-on fastening without shock-proof protection-cover, 400 VAC



D01	16	1 (1*)	4	01720.150000	J200660	20	
D02	63	1 (2*)	25	01721.250000	J218623	20	
D02	63	1 (4*)	25	01721.450000	W215552	20	
D03	100	1 (4*)	50	01722.450000	Q214535	10	
D01	16	3 (1*)	4	01730.152000	B216063	5	
D02	63	3 (2*)	25	01731.252000	Y217601	5	
D02	63	3 (4*)	25	01731.452000	M211979	5	

*Terminal type and dimensions see following pages

NEOZED Fuse bases

For snap-on fastening with shock-proof protection-cover



Size	Rated in Current (A)	Pole	Max. cross sect. mm ²	Previous Reference	Reference Number	Pack	Catalog Number
D01	16	1 (1*)	4	01720.170000	B211463	20	
D01	16	1 (3*)	4	01720.370000	T215550	20	
D01	16	3 (1*)	4	01730.172000	A219144	5	
D02	63	1 (2*)	25	01721.270000	M200663	20	
D02	63	1 (4*)	25	01721.470000	K218624	20	
D02	63	3 (2*)	25	01731.272000	E222874	5	
D02	63	3 (4*)	25	01731.472000	K213518	5	
D03	100	1 (4*)	50	01722.470000	F216067	10	

Dimensions see following pages



DIN Fuses D0-type NEOZED

D0 Fuse System

LINOZED Fuse bases

For snap-on fastening, 400VAC

Size	Rated in Current (A)	Pole	Max. cross sect. mm ²	Previous Reference	Reference Number	Pack	Catalog Number
D01	16	1	35	01724.000000	M217085	6	
D02	63	1	35	01725.000000	R215042	6	
D01	16	3	35	01734.000000	E201208	2	
D02	63	3	35	01735.000000	Y215554	2	

Dual function terminals

Dimensions see following pages



NEOZED Universal fuse bases

for screw mounting, 400 VAC

Size	Rated in Current (A)	Pole	Max. cross sect. mm ²	Previous Reference	Reference Number	Pack	Catalog Number
D01	16	1 (1*)	4	01720.130000	B222871	20	
D02	63	1 (2*)	25	01721.230000	D216571	20	
	63	1 (4*)	25	01721.430000	Q215041	20	
D03	100	1 (4*)	50	01722.430000	K214024	10	
D01	16	1 (1*)	4	01720.180000	G213515	20	
D02	63	1 (2*)	25	01721.280000	L211978	20	
D02	63	1 (4*)	25	01721.480000	G213009	20	
D03	100	1 (4*)	50	01722.480000	H219680	10	

* Terminal type and dimensions see following pages



NEOZED 3-pole fuse bases

without shock-proof protection, 400 VAC

Size	Rated in Current (A)	Pole	Max. cross sect. mm ²	Previous Reference	Reference Number	Pack	Catalog Number
------	----------------------	------	----------------------------------	--------------------	------------------	------	----------------

Screw fixing

D01	16	3 (1*)	4	01737.100000	A212497	5	
D02	63	3 (2*)	25	01738.200000	Z217602	5	

Snap-on fastening

D01	16	3 (1*)	4	01737.150000	E213007	5	
D02	63	3 (2*)	25	01738.250000	B218110	5	

* Terminal type and dimensions see following pages

NEOZED 3-pole fuse bases

without shock-proof protection, 400 VAC

Size	Rated in Current (A)	Pole	Max. cross sect. mm ²	Previous Reference	Reference Number	Pack	Catalog Number
------	----------------------	------	----------------------------------	--------------------	------------------	------	----------------

Clamp fixing for busbar 12 x 4...5mm, 15 x 4...5 mm

D02	63	1 (2*)	25	01746.200801	P222124	20	
-----	----	--------	----	--------------	---------	----	--

Clamp fixing for busbar 12 x 4 ...10 mm, 15 x 4 ...10 mm

D02	63	1 (2*)	25	01741.200001	L218625	20	
-----	----	--------	----	--------------	---------	----	--

Snap-on fastening for busbar 15 x 5 mm

D02	63	1 (2*)	25	01741.250000	G219679	20	
-----	----	--------	----	--------------	---------	----	--

* Terminal type and dimensions see following pages

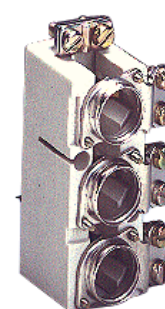

Clamp fixing



Snap-on fastening

NEOZED Fuse-links 2-63 A gG

440 VAC, 250 VDC



Size	Rated in Current (A)	Code Color	Previous Reference	Reference Number	Pack	Catalog Number
D01	2	rosa	01700.002400	E218780	50	
	4	braun	01700.004400	V219829	50	
	6	grün	01700.006400	X223028	50	
	10	rot	01700.010400	S201358	50	
D02	16	grau	01700.016400	C211096	50	
	20	blau	01701.020400	X212126	50	
	25	gelb	01701.025400	S213663	50	
	35	schwarz	01701.035400	C214684	50	
	50	weiß	01701.050400	J215702	50	
	63	Kupfer	01701.063400	N216718	50	

Dimensions see following pages

NEOZED Fuse bases

for snap-on fastening without shock-proof protection cover, 440 VAC



Size	Rated in Current (A)	Pole	Max. cross sect. mm ²	Previous Reference	Reference Number	Pack	Catalog Number
D01	16	1 (1*)	4	01720.150040	D201207	20	
D02	63	1 (2*)	25	01721.250040	M222122	20	
D02	63	1 (4*)	25	01721.450040	C216064	20	
D01	16	3 (1*)	4	01730.152040	C216570	5	
D02	63	3 (2*)	25	01731.252040	A218109	5	
D02	63	3 (4*)	25	01731.452040	C212499	5	

* Terminal type see following pages

LINOZED Fuse bases, Dual function clamps

for snap-on fastening, 440 VAC



Size	Rated in Current (A)	Pole	Max. cross sect. mm ²	Previous Reference	Reference Number	Pack	Catalog Number
D01	16	1	35	01724.000040	X217600	6	
D02	63	1	35	01725.000040	X215553	6	

Dimensions see following pages

LINOZED Fuse bases, Dual function terminal

for snap-on fastening, 440 VAC



Size	Rated in Current (A)	Pole	Max. cross sect. mm ²	Previous Reference	Reference Number	Pack	Catalog Number
D01	16	3	35	01734.000040	P201723	2	
D02	63	3	35	01735.000040	E216066	2	

Dimensions see following pages

General Purpose IEC Fuses



DIN Fuses D0-type NEOZED



D0 Fuse System

NEOZED - Special holding spring

Size	Previous Reference	Reference Number	Pack	Catalog Number
D01 Fuse-links in D02-socket	01713.000000	Z215049	50	
D02 Fuse-links in D03-socket	01709.000000	P214028	10	
D01 Fuse-links in DL-socket	01733.000000	J218117	100	



NEOZED - Spacer

Size	Previous Reference	Reference Number	Pack	Catalog Number
D02 Fuse-links in D03-socket	01707.000000	T211985	10	



NEOZED - Gauge ring key

Size	Previous Reference	Reference Number	Pack	Catalog Number
gauge-rings D01, D02, D03	01708.000000	J212505	10	



NEOZED - Screw-cap remover

Size	Previous Reference	Reference Number	Pack	Catalog Number
plastic screw-caps D01, D02	01716.000000	X222936	1	
	01716.333000	F200726	1	



NEOZED - Locking caps

Size	Previous Reference	Reference Number	Pack	Catalog Number
D01 supply boards (1)	01714.800000*	D212546*	25	
D01 Industry (2)	01714.810000	P213062	25	
D02 supply boards (1)	01715.800000*	R214582*	25	
D02 Industry (2)	01715.810000	Y215094	25	



* only for authorized energy supplier personnel
1) black top, red screw pitch
2) red top, black screw pitch

NEOZED - Locking keys

Size	Previous Reference	Reference Number	Pack	Catalog Number
D02 Supply boards	01714.820000*	K213564	10	
D02 Industry	01714.830000	J214069	10	

* for authorized energy supplier personnel only



General Purpose IEC Fuses

DIN Fuses
D0-type
NEOZED

D0 Fuse System

INNOZED

Der Neozed-Sicherungssockel mit innovativer Anschlusstechnik

Kunststoffe

mit höchsten Ansprüchen

- Sockelabdeckung aus flammwidrigem Polyamid
- Gehäuse aus glasfasergefülltem, duroplastischem Polyester
- Hohe mechanische und thermische Belastbarkeit

Innovative Anschlusstechnik

durch zweigeteilte Rahmenklemme.

- Kontaktierung der Einspeiseleitungen
- Anschluss der Verdrahtungsschienen
- Leitungen leichter einführbar Klemmstellen der Leitungen visuell kontrollierbar
- Einsparung von Montagezeit
- Zusätzliche Betriebssicherheit und Flexibilität

Verdrahtungsschienen

Folgende Schienen sind einsetzbar:

- 3-phasig 16 mm² – Ref.Nr. 2963.003
- 1-phasig 16 mm² – Ref.Nr. 2963.

Flexible Klemmentechnik

Unterschiedliche Leiterquerschnitte und Leiterarten sind problemlos klemmbar, sowohl eingangs- als auch abgangsseitig

- Flexibilität bei der Verdrahtung
- Erhöhung der Betriebssicherheit bei der Klemmung unterschiedlicher Leiter



35mm² und 4mm²
abgangsseitig



2 x 16mm²
auf der
Einspeiseseite



Zwillingsaderendhülle
auf der
Einspeiseseite



35mm² und 4mm²
auf der
Einspeiseseite



DIN Fuses D0-type NEOZED

D0 Fuse System Variabler Berührungsschutz



MIT SOCKELABDECKUNG FÜR VERTEILERBAU

Berührungsschutz durch einfaches Aufrasten der Sockelabdeckung.



OHNE SOCKELABDECKUNG IM INDUSTRIELLEN ANLAGENBAU

Berührungsschutz nach BGVA 2 auch ohne Sockelabdeckung bis 25mm²

Anschlussquerschnitt

- Einsparung der Montagezeit und der Kosten der Sockelabdeckung



FELDABDECKUNG AUS KUNSTSTOFF

individuell zugeschnitten

- einfach und kostengünstig

Geteilte Anschlussklemme zur Klemmung zweier Leitungen

	Einspeisung	Abgang
1. flexible Leitungen mit Aderendhülse		
zwei Leitungen gleichen Querschnitts:	bis max. 10mm ²	bis max. 16mm ²
zwei unterschiedliche Leitungen:	16mm ² u. max. 10mm ² 25mm ² u. max. 6mm ² 35mm ² u. max. 4mm ²	25mm ² u. max. 6mm ² 35mm ² u. max. 4mm ²
mit Zwillingsaderendhülse:	bis max. 16mm ²	bis max. 16mm ²
2. flexible, feindrähtige Leitungen ohne Aderendhülse		
zwei Leitungen gleichen Querschnitts:	bis max. 10mm ²	bis max. 16mm ²
zwei unterschiedliche Leitungen:	16mm ² u. max. 10mm ² 25mm ² u. max. 10mm ² 35mm ² u. max. 10mm ²	25mm ² u. max. 16mm ² 5mm ² u. max. 10mm ²
3. kurzschlussfeste Leitungen:		
zwei Leitungen gleichen Querschnitts:	bis max. 6mm ²	bis max. 6mm ²
Maximaler Anschlussquerschnitt der Zu- und Abgangsklemme: 35mm ²		



VORTEILE des INNOZED

- Schnellere Montage
- Höhere Betriebssicherheit
- Klemmstelle sichtbar vor Verdrahtungsschiene

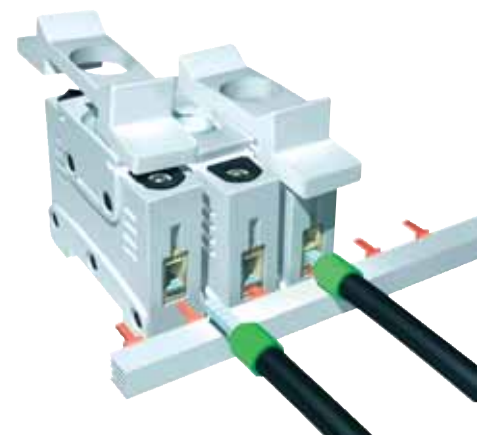

Vorschriften

IEC 60269-3-1
DIN VDE 0636 Teil 301

Prüfzeichen



Germany



Denmark



Norway

Baugrößen

Drei Baugrößen stehen zur Verfügung:

- Sicherungssockel D01
 - Gewinde E 14
 - Nennstrom 16A
 - für Sicherungseinsätze 2 ... 16A
- Sicherungssockel D02
 - Gewinde E 18
 - Nennstrom 63A
 - für Sicherungseinsätze 20 ... 63A
 - mit Spezialpasshülsen auch verwendbar für Sicherungseinsätze 2 ... 16A
- Sicherungssockel D03
 - Gewinde M 30 x 2
 - Nennstrom 100A
 - für Sicherungseinsätze 80 und 100A

Betriebsklassen

Die Betriebsklasse ist durch zwei Buchstaben gekennzeichnet.

Der erste Buchstabe gibt die Funktionsklasse, der zweite das zu

schützende Objekt an. Unser Lieferprogramm umfasst NEOZEDSicherungseinsätze nach DIN VDE 0636 für folgende Betriebsklassen:

- gG: Ganzbereichskabel- und Leitungsschutz
- gR: Ganzbereichs-Halbleiterschutz
- aM: Teilbereichs-Schaltgeräteschutz (Motorschutz)

Schaltvermögen

NEOZED-Sicherungseinsätze schalten im gesamten Bereich der Zeit-Stromkennlinie auch im Bereich der kritischen Ströme zuverlässig ab.

Das Schaltvermögen ist 50kA.

Klemmrausführungen der keramiksocket

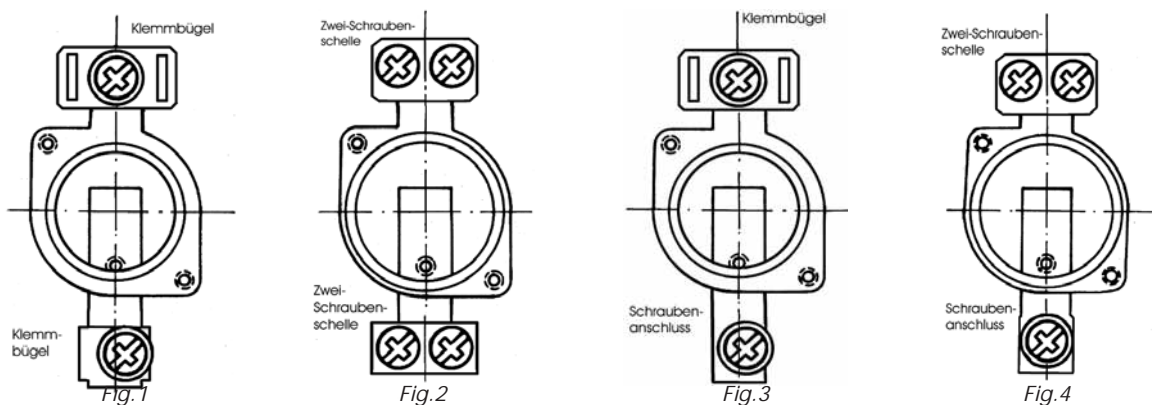



DIN Fuses

D0-type

NEOZED

D0 Fuse System

Ausschreibungstexte

Neozed-Sicherungssockel INNOZED

400VAC / 250VDC,
D01 (D02), 16A (63A),
Berührungsschutz nach BGVA 2 (auch ohne
Abdeckung)
Abdeckung abnehmbar bei eingeschraubter
Sicherung
Material Kunststoff zweigeteilte Rahmenklemmen

Neozed-Sicherungssockel LINOZED

400VAC / 250VDC
D01 (D02), 16A (63A)
Berührungsschutz nach BGVA 2
Material Kunststoff
Doppelfunktionsklemmen gefederter Fußkontakt

Neozed-Sicherungssockel

400VAC / 250VDC
D01 (D02, D03)
16A (63A, 100A)
Material Keramik
Anschlussart Klemmbügel (Schelle – Schelle,
Schraube – Schelle)

Neozed-Sicherungseinsatz

400VAC / 250VDC
D01 (D02, D03)
2 ... 16A (20 ... 63A, 80 ... 100A)
Betriebsklasse gG

Neozed-Sicherungseinsatz

400VAC / 400VAC
D02, 20A (25A, 35A)
Betriebsklasse aM für Schaltgeräteschutz in
Motorenstromkreisen

Neozed-Sicherungseinsatz

440VAC
D01 (D02, D03)
2 ... 16A (20 ... 63A, 80 ... 100A)
Betriebsklasse gR für Halbleiterschutz

Neozed-Schraubkappen

400VAC / 250VDC
D01 (D02, D03)
16A (63A, 100A)
Material Kunststoff (Keramik),
mit Prüfloch (und Plombierloch)

Neozed-Hülsenpasseinsatz

D01 (D02, D03)
2 ... 10A (20 ... 50A, 80A)
Neozed-Spezialhülsenpasseinsatz für D01-
Sicherungseinsätze in D02-Sicherungssockeln
D02, 2 ... 16A



DIN Fuses
D0-type
NEOZED



D0 Fuse System

2 - 100A, 400 (440)VAC, 250VDC Leitungsschutzsicherungen gG

Eigenverbrauch in W

Nennstrom in A	Größtwerte *	Messwerte
2	2,5/2,5	1,5
4	1,8	1,5
6	1,8	1,3
10	2,0	1,8
16	2,5/2,2	2,1
20	3,0/2,5	2,3
25	3,5/3,0	2,6
35	4,0	2,9
50	5,0	3,5
63	5,5	4,2
80	6,5	4,9
100	7,0	5,8

Selektivität

NEOZED-Sicherungseinsätze sind im Verhältnis 1:1,6 der Nennströme mit allen Sicherungseinsätzen selektiv, die folgenden

Anforderungen entsprechen:

Betriebsklasse gG entspr. IEC 60269-2-1, 60269-3-1

Betriebsklasse gG entspr. DIN VDE 0636 Teil 201, 301

NEOZED-Sicherungseinsätze sind untereinander und bei gemischtem Einsatz mit Sicherungseinsätzen anderer Lindner-Systeme im Verhältnis 1:1,25 selektiv, d.h. von Nennstromstufe zu Nennstromstufe. Beide Sicherungen sollten jedoch bei so enger Staffelung gleichen Umgebungseinflüssen ausgesetzt sein.

NEOZED-Sicherungseinsätze 32A

Zur Absicherung von 32A CEE Steckdosen sind entsprechend der neuen DIN VDE 0623 Teil 1/06.93 (DIN EN 60309-1) Sicherungseinsätze mit maximal 32A Bemessungsstrom vorgeschrieben.

Bisher durften 32A CEE Steckdosen ausnahmsweise mit 35A abgesichert werden.

Diese Ausnahmeregelung darf zukünftig für Neuanlagen nicht mehr angewendet werden, da die entsprechende Vorschrift DIN VDE 0623/03.77 nicht mehr gültig ist. Es gilt jedoch eine Übergangsfrist bis 2003-02-01.

Passorgane: Es sind die Hülsenpasseinsätze 35A zu verwenden.



DIN Fuses D0-type NEOZED

D0 Fuse System

Direkte Zuordnung bei Schutz von Kabel und Leitungen bei Überlast

Bei der Zuordnung von Überstrom-Schutzorganen zum Kabel- und Leitungsschutz sind nach DIN VDE 0100 Teil 430 folgende Bedingungen zu erfüllen:

$$I_B \leq I_N \leq I_Z \text{ (Nennstromregel) (1)}$$

$$I_2 \leq 1,45 \times I_N \text{ (Auslöseregel) (2)}$$

I_B - Betriebsstrom des Stromkreises

I_N - Nennstrom der ausgewählten Überstromeinrichtung

I_Z - zulässige Strombelastbarkeit des Kabels

I_2 - Auslösestrom der Schutzeinrichtung

DIN VDE 0636 Teil 301 wurde durch eine Zusatzprüfung "Abschalten mit $I_2 = 1,45 \times I_N$ in der konventionellen Prüfdauer" ergänzt.

NEOZED-Sicherungseinsätze gG erfüllen die Bedingungen dieser Zusatzprüfung. Damit ist eine direkte Zuordnung des Nennstromes des Sicherungseinsatzes zur Belastbarkeit der Leitung oder des Kabels möglich.

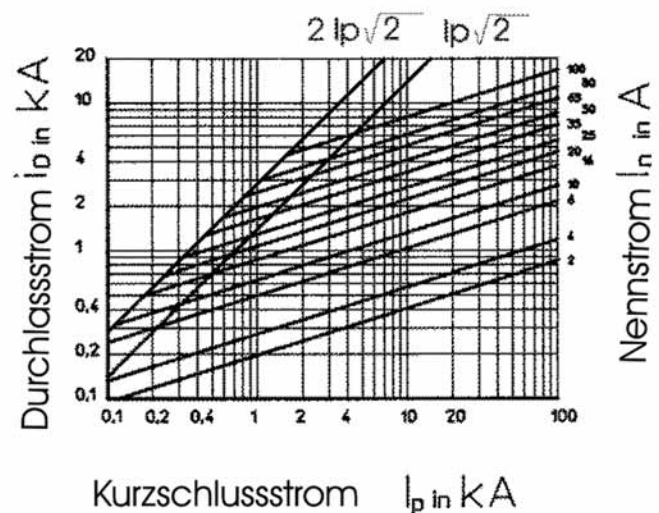
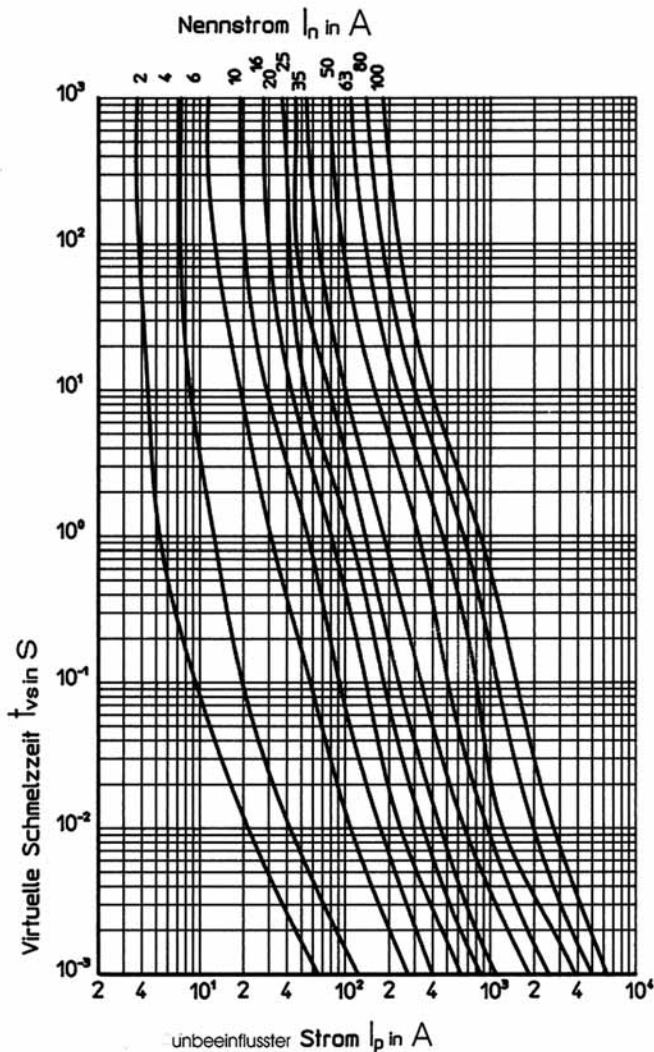



DIN Fuses
D0-type
NEOZED



D0 Fuse System

Vorschriften

IEC 60269-3-1
DIN VDE 0636 Teil 301
20/25/35A 400 (440)VAC, 250VDC
Schaltgeräteschutz-Sicherungen aM

Anwendung

NEOZED-Sicherungseinsätze der Betriebsklasse aM gewähren Motoren und Schaltgeräten den besten Schutz im Fall eines Kurzschlusses. Im Vergleich zu alternativen Schutzorganen haben Sicherungseinsätze der Betriebsklasse aM entscheidende Vorteile:
Besonders träges Abschaltverhalten im Überlastbereich verhindert unerwünschtes, vorzeitiges Auslösen des Schutzorganes; sehr flinkes Abschalten im Kurzschlussfall sorgt für höchste Kurzschlussstrombegrenzung und verhindert damit das Abbrennen und Verschweißen der Kontakte des Schaltgerätes.
Eine um bis zu 50% geringere Verlustleistung bietet entscheidende Vorteile bei häufigem Lastwechsel und Reversierbetrieb und spart außerdem noch Energiekosten.

Nennströme und Zeit-Strombereiche

NEOZED-Sicherungseinsätze aM gibt es nur in der Baugröße D02
20A 25A 35A
Zeit-Strombereiche nach IEC 60269

Selektivität

Selektivität erreicht man, wenn die vorgeschaltete Sicherung der Betriebsklasse gG mindestens drei Nennstromstufen größer als die Motorschutzsicherung aM ist. Dies verhindert unerwünschtes Abschmelzen der Vorsicherung bei kleinen Kurzschlussströmen.

- Beispiel: Nennstrom der Motorschutzsicherung 25A aM
Nennstrom der Vorsicherung 35A gG
Kurzschlussstrom im Motorstromkreis 500A
Selektivitätsgrenze lt. Tabelle 700A
- Ergebnis: keine Selektivität

Selektivitätsgrenzen in A

Nennstrom	20A	25A	35A	50A	63A	80A
20A aM	600	300	200	<100	<100	<100
25A aM	-	1500	700	100	<100	<100
35A aM	-	-	1000	300	200	<100

Vorsicherung der Betriebsklasse gG

Eigenverbrauch und Erwärmung

Die Verlustleistung der NEOZED-Sicherungseinsätze aM sind technisch bedingt geringer als bei den vergleichbaren der Betriebsklasse gG. Auch bei diesen Sicherungseinsätzen unterschreitet die LINDNER-Konstruktion die Größenwerte entsprechender Norm erheblich.

Eigenverbrauch in W

Nennstrom in A	Größtwerte *	Messwerte
20A	3,0/2,5	1,10
25A	3,5/3,0	1,05
35A	4	1,95

*) nach IEC 269-3-1, DIN VDE 0636 Teil 301/DIN VDE 0636 Teil 41

General Purpose IEC Fuses



DIN Fuses
D0-type
NEOZED

D0 Fuse System

Aufbau

Die NEOZED Sicherungseinätze der Betriebsklasse aM bestehen aus den gleichen Bauteilen wie die Standard-Typen der Betriebsklasse gG: Keramikhülse, Kontaktkappen, Kennmelder mit Kennmelderdraht, Löschsand. Nur der Schmelzleiter, der die Kennlinie und das Abschmelzverhalten einer Sicherung ausmacht, ist ein anderer. Zur Unterscheidung zu anderen Betriebsklassen sind die aM-Sicherungseinsätze in grüner Farbe beschriftet.

ZEIT-STROM-KENNLINIEN

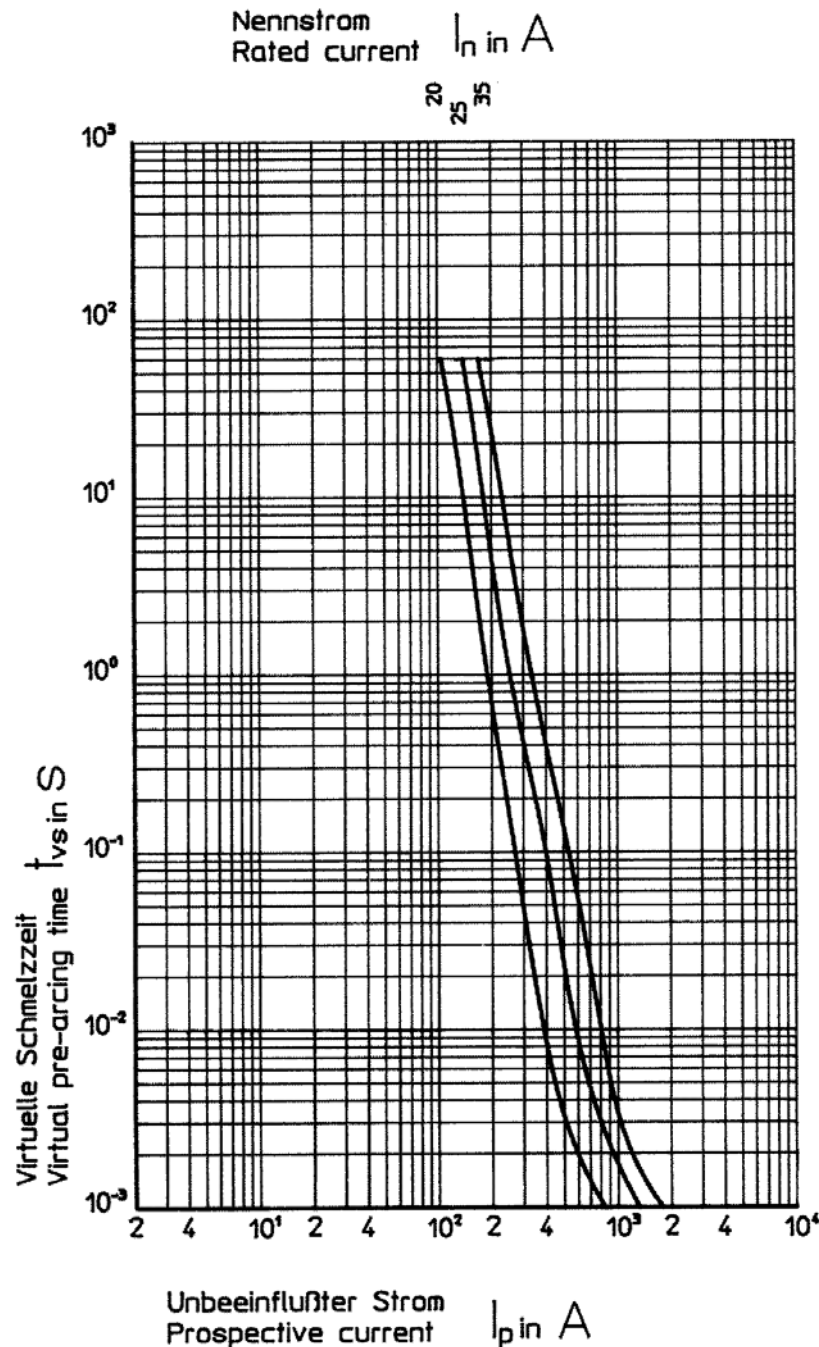

DURCHLASSSTROM-KENNLINIEN

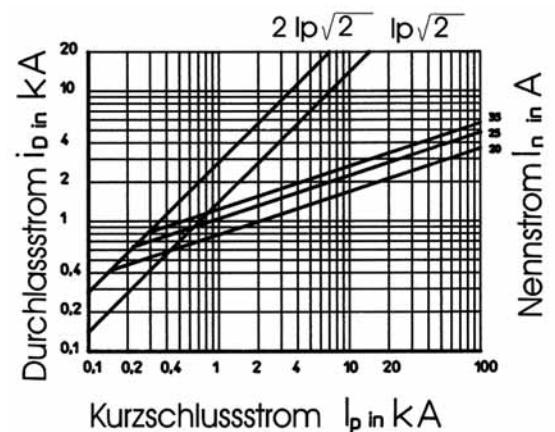

General Purpose IEC Fuses

DIN Fuses
D0-type
NEOZED

D0 Fuse System

INNOZED-Sicherungssockel

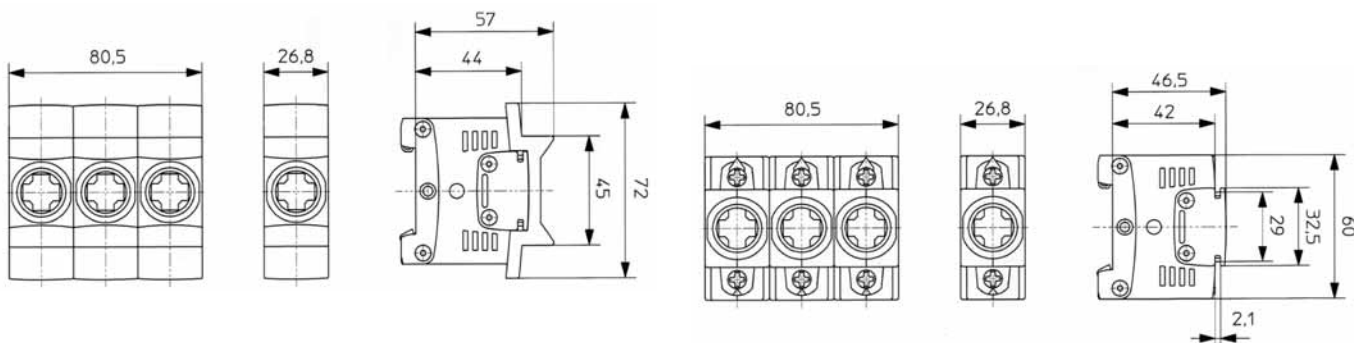

NEOZED-Sicherungssockel

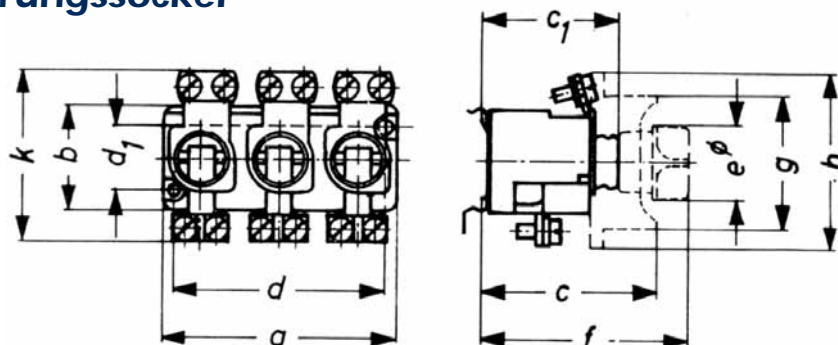

Referenz. Nummer	Catalog Number	a	b	c	c1	d	d1	eØ	f	g	h	k
1720.1		26	36	-	39,5	20	22	25,5	64	34Ø	-	50,5
1721.2/.4		26	36	-	39,5	20	22	25,5	64	34Ø	-	57,5
1722.4		44	50	-	44	32	32	40	74	52Ø	-	86
1730.1		81	36	-	39,5	74	22	25,5	64	-	-	50,5
1731.2/.4		81	36	-	39,5	74	22	25,5	64	-	-	57,5
1730.12		81	36	55	39,5	74	22	25,5	64	45	71	50,5
1731.22/.42		81	36	55	39,5	74	22	25,5	64	45	71	57,5
1720.15		26	36	-	41,5	20	22	25,5	66	34Ø	-	50,5
1721.25/.45		26	36	-	41,5	20	22	25,5	66	34Ø	-	57,5
1722.45		44	50	-	46	32	32	40	76	52Ø	-	86
1720.17		27	36	57	41,5	20	22	25,5	66	45	71	50,5
1721.27/.47		27	36	57	41,5	20	22	25,5	66	45	71	57,5
1722.47		44	50	54,5	46	32	32	40	76	45	71	86
1730.15		81	36	-	41,5	74	22	25,5	66	-	-	50,5
1731.25/.45		81	36	-	41,5	74	22	25,5	66	-	-	57,5
1730.17		81	36	57	41,5	74	22	25,5	66	45	71	50,5
1731.27/.47		81	36	57	41,5	74	22	25,5	66	45	71	57,5

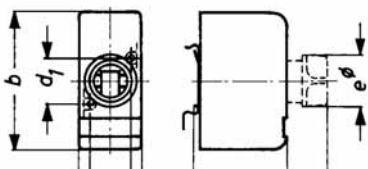

Referenz. Nummer	Catalog Number	a	b	c	d	d1	eØ	f
1720.13		31	70	44,5	20	22	25,5	64
1721.23/1721.43		31	70	44,5	20	22	25,5	64
1722.43		50	105	48	32	32	40	74
1720.18		31	70	46,5	20	22	25,5	66
1721.28/1721.48		31	70	46,5	20	22	25,5	66
1722.48		50	105	50	32	32	40	76

General Purpose IEC Fuses



DIN Fuses D0-type NEOZED

D0 Fuse System NEOZED Schraubkappen

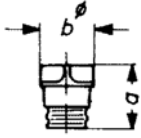

Referenz. Nummer	Catalog Number	a	b
1714.		29,5	23
1715.		29,5	23
1710.		31	25
1711.		31	25
1712.		37	40

NEOZED Abdeckungen

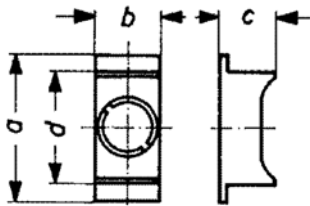

Referenz. Nummer	Catalog Number	a	b	c
1718.008		60	26,8	23
1728.7		71	26,8	23
1728.		60	44	18
1732.7		71	81	23

NEOZED Hülsenpasseinsätze

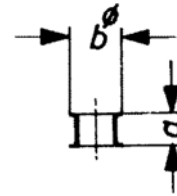

Referenz. Nummer	Catalog Number	a	b
1705.		10	12
1706.		10	16
1707.		10	27

NEOZED Sicherungseinsätze

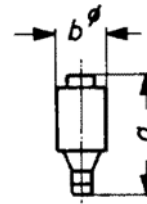

Referenz. Nummer	Catalog Number	a	b
D01		36	11
D02		36	15
D03		43	22

LINOZED-Sicherungssockel

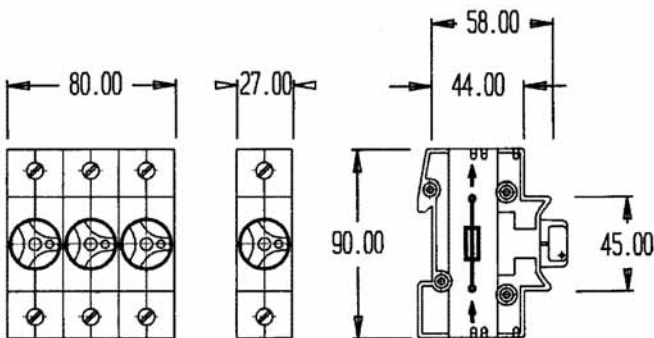



General Purpose IEC Fuses

DIN Fuses
D0-type
NEOZED

D0 Fuse System

NEOZED-Reiter-Sicherungssockel mit Schellenbefestigung, 400VAC

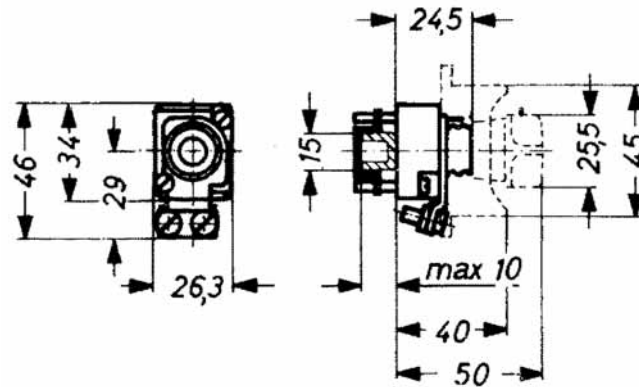

NEOZED-Reiter-Sicherungssockel mit Schnappbefestigung, 400VAC

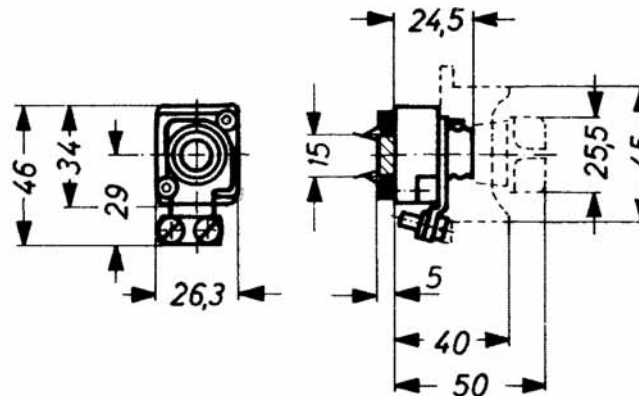

NEOZED-Reihen-Sicherungssockel

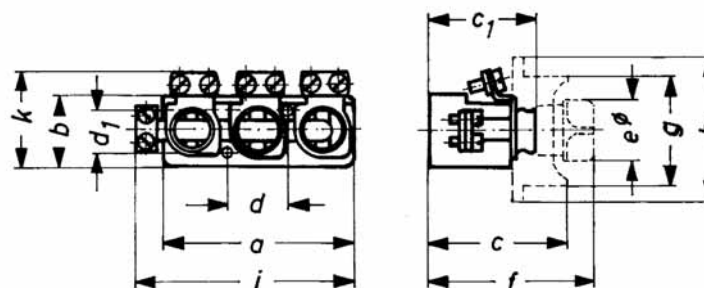

Referenz. Nummer	Catalog Number	a	b	c	c1	d	d1	eØ	f	g	h	i	k
1737.12		80,5	30	55	39,5	22	20	25,5	64	45	71	88,5	36,5
1738.22		80,5	30	55	39,5	22	20	25,5	64	45	71	91,5	44,5
1737.17		80,5	30	57	41,5	22	20	25,5	66	45	71	88,5	36,5
1737.27		80,5	30	57	41,5	22	20	25,5	66	45	71	91,5	44,5



General Purpose IEC Fuses

DIN Fuses
D-type
DIAZED



D Fuse System

2 – 200 A, 500 V, 690 V

Line protection fuses gL-gG
IEC 60269 parts 1, 3 and 3-1
DIN VDE 0636 Parts 10, 30 and 31

Dimensions are stipulated in the following regulations:

- DIN 49360 D Fuse-links
- DIN 49515 D Fuse-links
- DIN 49367 D Fuse-links, long design
- DIN 49514 D Screw caps
- DIN 49510 D Fuse bases
- DIN 49362 D Gauge rings
- DIN 49516 D Screw gauge pieces

Structure of the D fuse system

Like the modern NEOZED system, the D-Fuse system consists of fuse base, gauge piece, fuse link and screw cap. It is designed for a rated voltage of 500V. Noninterchangeability of rated current is guaranteed from one current level to the other above 6 Amps. This is ensured by graduating the diameter of the bottom contact of the fuse-link along with corresponding fixed diameters for the gauge piece.



General Purpose IEC Fuses



DIN Fuses

D-type

DIAZED

D Fuse System

D Fuse bases

for snap-on fastening 500 VAC / 690 VAC

Size	Rated in Current (A)	Pole	Max. cross sect. mm ²	Previous Reference	Reference Number	Pack	Catalog Number
without shock-proof protection cover							
DII	25	1*	6	00685.100000	K207055	15	
DIII	63	4*	16	00686.400000	V215597	15	
with shock-proof protection cover							
DII	25	1	6	00685.110000	D211511	10	
DIII	63	4	16	00686.410000	C216110	10	

* Terminal type see following pages



D Fuse bases

for screw fixing 500 VAC / 690 VAC

Size	Rated in Current (A)	Pole	Max. cross sect. mm ²	Previous Reference	Reference Number	Pack	Catalog Number
without shock-proof protection cover							
DII	25	1*	6	00081.100000	K218670	15	
DIII	63	4*	16	00072.400000	H212021	15	
with shock-proof protection cover							
DII	25	1*	6	00081.110000	Z219189	10	
DIII	63	4*	16	00072.410000	A212543	10	

* Terminal type see following pages



D Fuse-links

2 - 200A fast acting (CEE-16 standard), 500 VAC

Size	Rated in Current (A)	Gauge Color	Previous Reference	Reference Number	Pack	Catalog Number
NDZ	2	pink	00594.002000	C222918	25	
NDZ	4	brown	00594.004000	L200708	25	
NDZ	6	green	00594.006000	A201250	25	
NDZ	10	red	00594.010000	L201766	25	
NDZ	16	gray	00594.016000	D207049	25	
NDZ	20	blue	00594.020000	B211509	25	
NDZ	25	yellow	00594.025000	Y212541	25	
DII	2	pink	00597.002000	E213559	25	
DII	4	brown	00597.004000	D214064	25	
DII	6	green	00597.006000	L214577	25	
DII	10/6 (1)	red	00597.610000	X218152	25	
DII	10	red	00597.010000	S215089	25	
DII	16	gray	00597.016000	A216108	25	
DII	20	blue	00597.020000	J217128	25	
DII	25	yellow	00597.025000	P217639	25	
DIII	35	Black	00598.035000	J218669	25	
DIII	50	white	00598.050000	J222165	25	
DIII	63	copper	00598.063000	M200709	25	

(1) with base contact stud for 6 A



D Fuse System

D Fuse-links

2 -200 A gG, 500 VAC



Size	Rated in Current (A)	Gauge Color	Previous Reference	Reference Number	Pack	Catalog Number
NDZ	2	pink	00594.002700	W212539	25	
NDZ	4	brown	00594.004700	G213055	25	
NDZ	6	green	00594.006700	C213557	25	
NDZ	10	red	00594.010700	B214062	25	
NDZ	16	grey	00594.016700	J214575	25	
NDZ	20	blue	00594.020700	O215087	25	
NDZ	25	yellow	00594.025700	O215593	25	
D II	2	pink	00597.002700	Z219718	25	
D II	4	brown	00597.004700	G222163	25	
D II	6	green	00597.006700	B222917	25	
D II	10/6 f1	red	00597.610700	D213558	25	
D II	10	red	00597.010700	K200707	25	
D II	16	grey	00597.016700	K201765	25	
D II	20	blue	00597.020700	A211508	25	
D II	25	yellow	00597.025700	X212540	25	

1 with base contact stud for 6 A (without VDE test mark)

D III	35	black	00598.035700	C214063	25	
D III	50	white	00598.050700	K214576	25	
D III	63	copper	00598.063700	R215088	25	
D IV	80	silver	00595.080700	V216609	10	
D IV	100	red	00595.100700	M217637	10	
D V	125	yellow	00596.125700	V218150	10	
D V	160	copper	00596.160700	G218667	10	
D V	200	blue	00596.200700	W219186	10	

Characteristics see following pages

D Fuse system 690 VAC

In this design, the fuse base and gauge piece correspond to the 500 V standard for D III (E33). The extended fuse links D III and a special extended screw cap serve to complement the present system. D-type 690 V fuses are only available in size III.

D Fuse-links

2 - 63 A gG 690 VAC



Size	Rated in Current (A)	Gauge Color	Previous Reference	Reference Number	Pack	Catalog Number
D III	2	pink	00603.002700	R215594	25	
D III	4	brown	00603.004700	Z216107	25	
D III	6	green	00603.006700	W216610	25	
D III	10	red	00603.010700	H217127	25	
D III	16	grey	00603.016700	N217638	25	
D III	20	blue	00603.020700	W218151	25	
D III	25	yellow	00603.025700	H218668	25	
D III	35	black	00603.035700	X219187	25	
D III	50	white	00603.050700	A219719	25	
D III	63	copper	00603.063700	H222164	25	

D Screw-cap long design 690 VAC



D III	63		00605.000000	L218671	25	
-------	----	--	--------------	---------	----	--

Dimensions see following pages

General Purpose IEC Fuses



DIN Fuses

D-type

DIAZED

D Fuse System

D Screw caps

Porcelain and Plastic, 500 VAC

Size	Rated in Current (A)	Gauge Color	Previous Reference	Reference Number	Pack	Catalog Number
Porcelain with testing hole						
DII	25	E 27	00690.000200	E218619	20	
DIII	63	E 33	00691.000200	B213004	20	
Porcelain without testing hole						
NDZ	25	E 16	00589.000000	Z216613	50	
DII	25	E 27	00690.000000	Z218108	20	
DIII	63	E 33	00691.000000	F211973	20	
DIV	100	R11/4	00592.000000	Y216060	10	
Plastic with testing hole						
DII	25	E 27	02071.000000	L201720	20	
DII	63	E 33	02072.000000	E214019	20	



D Gauge piece

Size	Rated in Current (A)	Gauge Color	Previous Reference	Reference Number	Pack	Catalog Number
NDZ	2	pink	01655.002000	B212544	50	
NDZ	4	brown	01655.004000	M213060	50	
NDZ	6	green	01655.006000	H213562	50	
NDZ	10	red	01655.010000	G214067	50	
NDZ	16	grey	01655.016000	P214580	50	



D Screw gauge pieces for DII / DIII

D II	2	pink	01657.002000	A219190	25	
D II	4	brown	01657.004000	D219722	25	
D II	6	green	01657.006000	L222167	25	
D II	10	red	01657.010000	F222921	25	
D II	16	grey	01657.016000	P200711	25	
D II	20	blue	01657.020000	D201253	25	
D II	25	yellow	01657.025000	P201769	25	
D III	35	black	01658.035000	C207071	25	
D III	50	white	01658.050000	E211512	25	
D III	63	copper	01658.063000	J212022	25	



D Gauge rings for DII / DIII, TRI60 System

D II	2	pink	01652.002000	W215092	50	
D II	4	brown	01652.004000	W215598	50	
D II	6	green	01652.006000	D216111	50	
D II	10	red	01652.010000	A216614	50	
D II	16	grey	01652.016000	M217131	50	
D II	20	blue	01652.020000	S217642	50	
D II	25	yellow	01652.025000	A218155	50	
D III	2	pink	01653.002000	M218672	50	
D III	4	brown	01653.004000	E219723	50	
D III	6	green	01653.006000	M222168	50	
D III	10	red	01653.010000	G222922	50	
D III	16	grey	01653.016000	Q200712	50	
D III	20	blue	01653.020000	E201254	50	
D III	25	yellow	01653.025000	Q201770	50	
D III	35	black	01653.035000	L207079	50	
D III	50	white	01653.050000	F211513	50	



Dimensions see following pages



General Purpose IEC Fuses

DIN Fuses D-type DIAZED



Key for D gauge pieces

D Fuse System



Size	Previous Reference	Reference Number	Pack	Catalog Number
DII, DIII	01657.993000	E216112	10	

D Cover insulating material



Single pole

D II (40 mm width)	00685.700000*	H214068	30	
D III (50 mm width)	00686.700000*	X215093	30	
D II (45 mm width)	00685.709000	Q214581	30	
D III (54 mm width)	00686.709000	X215599	30	

* Standart version

Triple pole

D II	00625.700000	N213061	8	
D III	00626.700000	J213563	8	

D Touch Protection rings



Plastic

D II	00181.900000	K222120	50	
D III	00182.900000	A222870	50	

Porcelain

D II	00081.900000	C219675	30	
D III	00072.900000	K212023	20	

D Adapter fittings



for DII-fuses links in D III-bases

D II/ D III	00581.000000	C212545	50	
-------------	--------------	---------	----	--

DII Supply boards ¹⁾	02071.800000*	B216615*	10	
DII Industry ²⁾	02071.810000	N217132	10	
DIII Supply boards ¹⁾	02072.800000*	T217643*	10	
DIII Industry ²⁾	02072.810000	B218156	10	

* For authorized energy supplier personnel only

¹⁾ black top, red screw pitch

²⁾ red top, black screw pitch

D Locking caps



Locking keys

Supply boards	01714.820000*	K213564*	10	
Industry	01714.830000	J214069	10	

*For authorized energy supplier personnel only

General Purpose IEC Fuses



DIN Fuses D-type DIAZED

D Fuse System

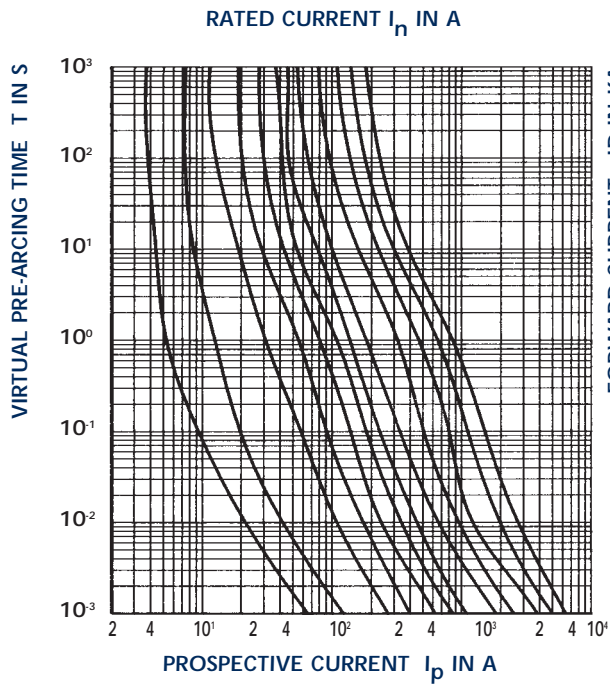

Time-current characteristics of D Fuses 2...100 A gL-gG

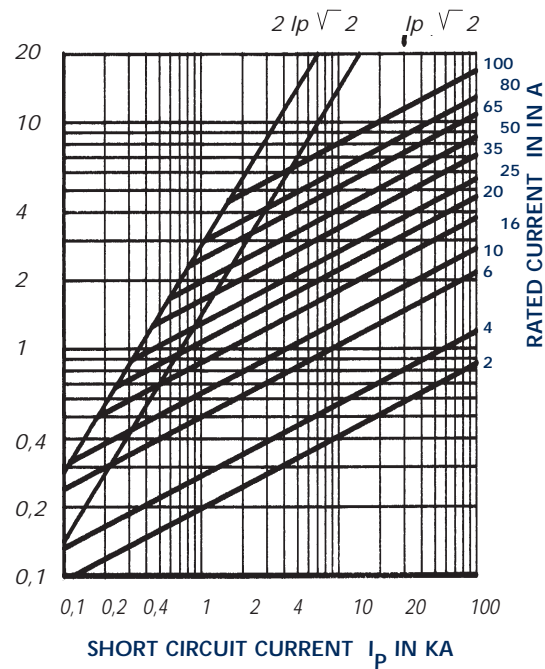

Forward current characteristics of DIAZED fuses 2...100 A gL-gG

Terminal types

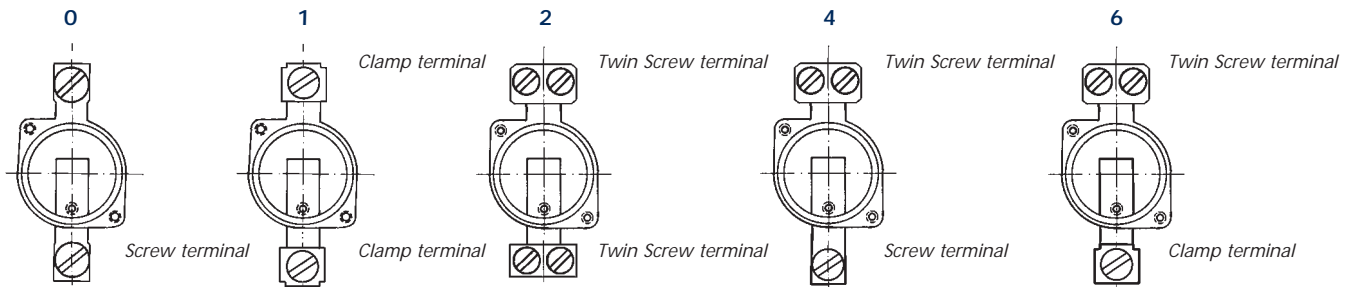

Dimensions

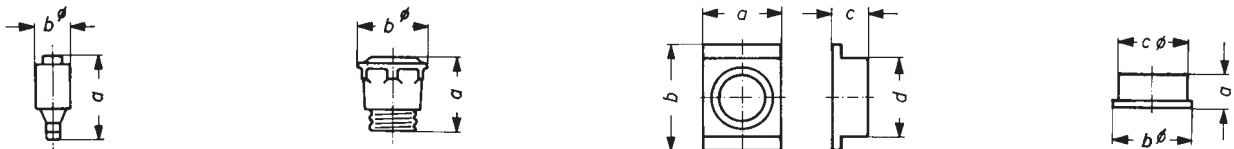

D Fuse-links

Cat Number	a ₁	b _X
NDZ	50	12
DII	50	22
DIII	50	27
DIV	63	37
DV	65	45

D Screw caps

Cat Number	a	b
690.0002	42	34
691.0002	43	42
589.0002	34	27
690	42	34
691	43	42
592	52	60
2071	42	33
2072	43	40

D Covers

Cat Number	a	b	c
685.7	40	90	22
686.7	50	90	22
685.709	45	90	22
686.709	54	90	22
625.7	107	107	51
626.7	127	130	51

D touch protection rings

Cat Number	a	b	c
181.9	17,5	44,5	40,5
182.9	19	54	50,5
81.9	18,5	43,5	39,8
72.9	18	53,5	50,5



General Purpose IEC Fuses

DIN Fuses
D-type
DIAZED



Dimensions

D Fuse System

Catalog number	Sizes in mm						
	a	b	c	d	d1	eX	f
99	40	70	53	32	–	38	82
199	40	70	54	20	–	38	83
200	50	90	54	20	–	48	83

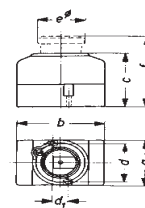

Catalog number	Sizes in mm							
	a	b	c	c1	d	d1	eX	f
625	90	81	54.5	46	80	35	37	81
626	109	100	54.5	46	95	49.5	46.5	81
625*	107	107	51	–	–	–	–	–
626*	127	130	51	–	–	–	–	–

* with cover cap

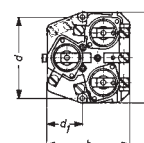
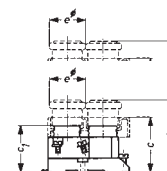

Catalog number	Sizes in mm											
	a	b	c	c1	d	d1	eX	f	X	h	i	k
685/81	38	40	60	46	29	27	38	82	43	–	–	60
686/72	46	44	57	48	35	33,5	48	84	52	–	–	73

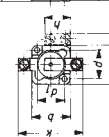
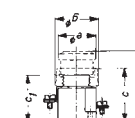

Catalog number	Sizes in mm								
	a	b	c	d	e	f	g	g1	
120	42	52	60	44	38	85	12	37	
121	52	62	63	54	48	88	13	38	

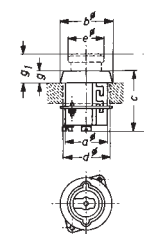

General Purpose Fuses IEC

BS88-2 Fuses gG/gM Sizes A,B,C



- The fuse complies with standard EN 60269-2 section II and standard BS 88 part 2.
- These fuses are designed for :
 - "General purpose use" protection (gG type)
 - motor protection (gM type)
- This fuse range insures an excellent current limitation for all overloads on a large range of applications. Their size cannot allow exchange by other fuses of higher rating in their range. They are screwed into fuseholders or bolted directly onto busbars, or in fuse interruptors disconnectors.

A, B and C types - gG curve

Features/Benefits

- Fast gG curve
- Very current limiting
- Tested in DC
- Voltage 415VAC and 250VDC
- High breaking capacity : 80kA @ 415VAC and 40kA @ 250VDC tested
- A type: bracket connection,
- B type: blade with single central fixing hole connection
- C type: blade with two central fixing hole connection.

Ratings

▪ A type

A1 : from 2A to 32A
A2 : from 2A to 32A
A3 : from 40A to 100A
A4 : from 32A to 100A
Overrating till 200A

▪ B type

B1 : from 32A to 100A
B2 : from 125A to 200A
B3 : from 250A to 315A
B4 : from 355A to 400A

▪ C type

C1 : from 355A to 400A
C2 : from 450A to 630A
C3 : from 670A to 800A

A and B types - gM curve

Features/Benefits

- Fast curve gM
- Very current limiting
- Voltage 415VAC
- High breaking capacity : 80kA @ 415VAC tested
- A type : bracket connection,
- B type : blade with single central fixing hole connection

Ratings

▪ A type

A1: 20A
A2: 30A
A3: 63A
A4: 100A and 200A

▪ B type

B1: 100A
B2: 200A
B3: 315A

Applications

- Power cable protection
- Distribution panel protection
- Control Panel
- Main circuit
- Distribution panel
- Lighting, heating and electrical equipments
- Capacitor, Circuit breakers, batteries
DC circuit protection.

Approvals

- Asta²⁰Certified

Applications

- Motor protection
- Inductive load protections
- Transient overloads
- Electrical equipment using motors protection
Capacitor

Approvals

- Asta²⁰Certified

General Purpose Fuses IEC

BS88-2 Fuses gG/gM Sizes A,B,C

Standard fuse ampere rating

A, B and C types - gG curve

A type

Type	Rating	Ref. no	Designation	Pack.	Catalog Number
A1	2	N226263	2A1	10	
A1	4	P226264	4A1	10	
A1	6	O226265	6A1	10	
A1	10	R226266	10A1	10	
A1	16	S226267	16A1	10	
A1	20	T226268	20A1	10	
A1	25	V226269	25A1	10	
A1	32	W226270	32A1	10	
A2	2	Z226273	2A2	10	
A2	4	A226274	4A2	10	
A2	6	B226275	6A2	10	
A2	10	C226276	10A2	10	
A2	16	D226277	16A2	10	
A2	20	V227833	20A2	10	
A2	25	E226278	25A2	10	
A2	32	F226279	32A2	10	
A3	40	L226284	40A3	10	
A3	50	M226285	50A3	10	
A3	63	N226286	63A3	10	
A3	80	P226287	80A3	10	
A3	100	O226288	100A3	10	
A4	32	T226291	32A4	5	
A4	40	V226292	40A4	5	
A4	50	W226293	50A4	5	
A4	63	X226294	63A4	5	
A4	80	Y226295	80A4	5	
A4	100	Z226296	100A4	5	
A4X*	125	D226300	125A4X	5	
A4X*	160	E226301	160A4X	5	
A4X*	200	F226302	200A4X	5	

* Current ratings additional to BS88.

B type

Type	Rating	Ref. no	Designation	Pack.	Catalog Number
B1X*	32	J226305	32B1X	10	
B1X*	40	K226306	40B1X	10	
B1X*	50	L226307	50B1X	10	
B1X*	63	M226308	63B1X	10	
B1	80	N226309	80B1	5	
B1	100	P226310	100B1	5	
B2	125	T226314	125B2	5	
B2	160	V226315	160B2	5	
B2	200	W226316	200B2	5	
B3	250	Z226319	250B3	1	
B3	315	A226320	315B3	1	
B3X*	250	C226322	250B3X	1	
B3X*	315	D226323	315B3X	1	
B4	355	E226324	355B4	1	
B4	400	F226325	400B4	1	

C type

Type	Rating	Ref. no	Designation	Pack.	Catalog Number
C1	355	G226326	355C1	1	
C1	400	H226327	400C1	1	
C2	450	J226328	450C2	1	
C2	500	K226329	500C2	1	
C2	560	L226330	560C2	1	
C2	630	M226331	630C2	1	
C3	670	N226332	670C3	1	
C3	710	P226333	710C3	1	
C3	750	O226334	750C3	1	
C3	800	R226335	800C3	1	

General Purpose Fuses IEC

BS88-2 Fuses gG/gM Sizes A,B,C

A and B types - gM curve

A type

Type	Rating	Ref. no	Designation	Pack.	Catalog Number
A1	20M25	X226271	20M25A1	10	
A1	20M32	Y226272	20M32A1	10	
A2	32M40	G226280	32M40A2	10	
A2	32M50	H226281	32M50A2	10	
A2	32M63	K226283	32M63A2	10	
A3	63M80	R226289	63M80A3	10	
A3	63M100	S226290	63M100A3	10	
A4	100M125	A226297	100M125A4	5	
A4	100M160	B226298	100M160A4	5	
A4	100M200	C226299	100M200A4	5	
A4X	200M250	G226303	200M250A4X	1	
A4X	200M315	H226304	200M315A4X	1	

B type

Type	Rating	Ref. no	Designation	Pack.	Catalog Number
B1	100M125	Q226311	100M125B1	5	
B1	100M160	R226312	100M160B1	5	
B1	100M200	S226313	100M200B1	5	
B2	200M250	X226317	200M250B2	1	
B2	200M315	Y226318	200M315B2	1	
B3	315M400	B226321	315M400B3	1	

Dimensions

A type

Ref. BS 88	Current ratings (A)	Dimensions (mm & In)									
		A max	B max	D max	E max	F nom	G nom	H nom	J nom	K max	
A1	2, 4, 6, 10, 16, 20, 25*, 32*, 20M25, 20M32	mm In	33 1-1/4	12,7 1/2	56 2-3/16	9,5 3/8	0,8 1/32	44,25 1-3/4	4,8 3/16	open hole	14,3 9/16
A2	2, 4, 6, 10, 16, 20, 25, 32, 32M40, 32M50, 32M63	mm In	49 1-15/16	22 7/8	86 3-3/8	9 11/32	1,2 3/64	73 2-7/8	5,5 7/32	8 5/16	24 15/16
A3	40, 50, 63	mm In	49 1-15/16	22 7/8	89 3-1/2	13 1/2	1,2 3/64	73 2-7/8	5,5 7/32	open hole	24 15/16
A3	80*, 100*, 63M80, 63M100	mm In	49 1-15/16	26 1-1/32	89 3-1/2	13 1/2	1,2 3/64	73 2-7/8	5,5 7/32	open hole	28 1-3/32
A4	32, 40, 50, 63	mm In	51 2	22 7/8	110 4-5/16	20 3/4	2,4 3/32	94 3-11/16	8,7 11/32	11 7/16	25,4 1
A4	80, 100	mm In	51 2	26 1-1/32	110 4-5/16	20 3/4	2,4 3/32	94 3-11/16	8,7 11/32	11 7/16	29 1-1/8
A4X	125, 160, 200, 100M125, 100M160, 100M200	mm In	51 2	35 1-3/8	110 4-5/16	20 3/4	2,4 3/32	94 3-11/16	8,7 11/32	11 7/16	38 1-1/2
A4X	200M250*, 200M315*	mm In	51 2	41 1-5/8	110 4-5/16	20 3/4	2,4 3/32	94 3-11/16	8,7 11/32	11 7/16	45 1-3/4

* Current ratings additional to BS88.

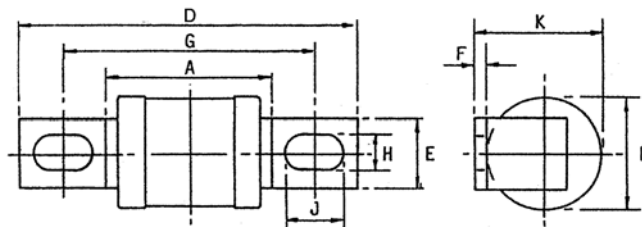

General Purpose Fuses IEC

BS88-2 Fuses gG/gM Sizes A,B,C

Dimensions

B type

Ref. BS 88	Current ratings (A)	Dimensions (mm & In)								
			A max	B max	D max	E max	F nom	G nom	H nom	I nom
B1X	32, 40, 50, 63	mm in	45 1-3/4	22 7/8	137 5-3/8	15 9/16	1,4 3/64	111 4-3/8	8,7 11/32	14 9/16
B1	80, 100	mm in	45 1-3/4	26 1/32	137 5-3/8	20 3/4	3,2 1/8	111 4-3/8	8,7 11/32	14 9/16
B1	100M125, 100M160, 100M200	mm in	45 1-3/4	35 1-3/8	137 5-3/8	20 3/4	3,2 1/8	111 4-3/8	8,7 11/32	14 9/16
B2	125, 160, 200	mm in	45 1-3/4	35 1-3/8	137 5-3/8	20 3/4	3,2 1/8	111 4-3/8	8,7 11/32	14 9/16
B2	200M250, 200M315	mm in	45 1-3/4	41 1-5/8	137 5-3/8	26 1-1/32	3,2 1/8	111 4-3/8	8,7 11/32	14 9/16
B3	250, 315	mm in	45 1-3/4	41 1-5/8	137 5-3/8	26 1-1/32	3,2 1/8	111 4-3/8	8,7 11/32	14 9/16
B3	315M400	mm in	45 1-3/4	51 2	137 5-3/8	26 1-1/32	6,4 1/4	111 4-3/8	8,7 11/32	14 9/16
B3X	250, 315	mm in	45 1-3/4	41 1-5/8	159 6-1/4	26 1-1/32	3,2 1/8	133 5-1/4	10,3 13/32	14 9/16
B4	355, 400	mm in	52 2-1/16	51 2	137 5-3/8	26 1-1/32	6,4 1/4	111 4-3/8	8,7 11/32	16 5/8

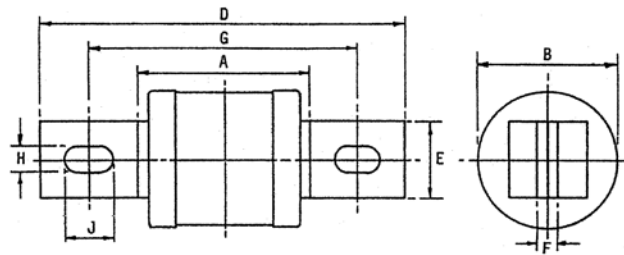

C type

Ref. BS 88	Current ratings (A)	Dimensions (mm & In)									
			A max	B max	D max	E max	F nom	G nom	H nom	J nom	L nom
C1	355*, 400	mm in	52 2-1/16	51 2	210 8-1/4	26 1-1/32	6,3 1/4	133 5-1/4	10,3 13/32	16 5/8	25,4 1
C2	450*, 500, 560*, 630	mm in	54 2-1/8	61 2-3/8	210 8-1/4	26 1-1/32	7,8 5/16	133 5-1/4	10,3 13/32	16 5/8	25,4 1
C3	670*, 710, 750*, 800	mm in	56 2-1/16	73 2	210 8-1/4	26 1-1/32	9,5 3/8	133 5-1/4	10,3 13/32	16 5/8	25,4 1

* Current ratings additional to BS88.

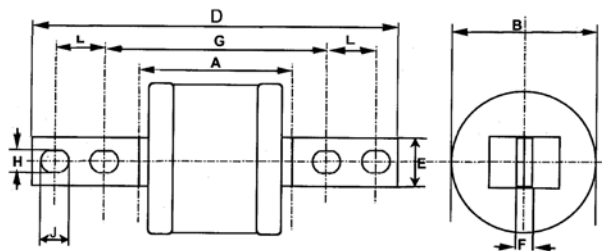

gG and gM fuse-link selection

Fuse-link selection for 3 phase 415 V AC induction motor circuit

kW	Motor rating HP	In	Direct-on-line start (7 x FLC for 10 sec) Fuse-link rating (amperes)		Assisted start (3,5 x FLC for 20 sec) Fuse-link rating (amperes)	
			gG	gM	gG	gM
0,75	1	2	6	-	4	-
1,1	1,5	2,5	10	-	6	-
1,5	2	3,5	10	-	6	-
2,2	3	5	16	-	10	-
3	4	6,5	20	-	16	-
4	5	8	25	20M25	16	-
5,5	7,5	11	32	20M32	20	-
7,5	10	14	40	32M40	25	20M25
10	13,5	19	50	32M50	32	20M32
11	15	21	50	32M50	32	-
15	20	28	63	32M63	40	32M40
18,5	25	35	80	63M80	50	-
22	30	41	100	63M100	50	-
26	35	48	100	63M100	63	-
30	40	55	125	100M125	80	63M80
33	45	62	160	100M160	80	63M80
37	50	69	160	100M160	100	-
45	60	83	200	100M200	100	-
53	70	97	200	100M200	125	100M125
55	75	100	200	100M200	125	100M125
60	80	110	250	200M250	160	-
67	90	120	250	200M250	160	-
75	100	135	250	200M250	160	-
90	120	160	315	200M315	200	-
93	125	170	355*	315M400*	200	-
110	150	200	400	315M400*	250	200M250
130	175	230	400	315M400*	315	-
150	200	260	450*	400M500*	315	-
160	215	280	500	400M500*	355*	315M400*
170	225	290	500	400M500*	355*	315M400*
180	250	320	560*	-	400	-
200	270	350	630	-	400	-
220	300	380	670*	-	450	400M500*
250	335	420	710*	-	500	-
260	350	450	750*	-	560*	-
300	400	500	800	-	630	-

* Current ratings additional to BS88.

Maximum full load current starting capability

Direct-on-line start (7 x FLC for 10 sec)			Assisted start (3,5 x FLC for 20 sec)		
Fuse-link rating (amperes)		Maximum motor	Fuse-link rating (amperes)		Maximum motor
gG	gM	In	gG	gM	In
2	-	0,6	2	-	1,3
4	-	1,3	4	-	2,4
6	-	2,3	6	-	4,3
10	-	4,1	10	-	6,4
16	-	6,0	16	-	11
20	-	7,9	20	-	14
25	20M25	10	25	20M25	19
32	20M32	13	32	-	24
40	32M40	18	40	32M40	31
50	32M50	26	50	-	46
63	32M63	30	63	-	51
80	63M80	40	80	-	69
100	63M100	54	100	-	94
125	100M125	61	125	-	110
160	100M160	82	160	-	150
200	-	110	200	-	180
250	200M250	150	250	-	220
315	200M315	170	315	-	250
355*	315M400*	200	355*	-	310
400	315M400*	240	400	-	340
450*	400M500*	280	450*	400M500*	380
500	400M500*	310	500	-	430
560*	-	350	560*	-	460
630	-	380	630	-	500
670*	-	420	670*	-	530
710*	-	450	710*	-	550
750*	-	480	750*	-	570
800	-	510	800	-	600

* Current ratings additional to BS88.

This data is based upon normal starting conditions and usual efficiency and power factor.

Conditions such as long run-up times, large numbers of start in succession, high ambient temperature or abnormal transients during start/delta switching may necessitate adjustments to fuse-link selection.

General Purpose Fuses IEC

BS88-2 Fuses gG/gM Sizes A,B,C

Time/current data

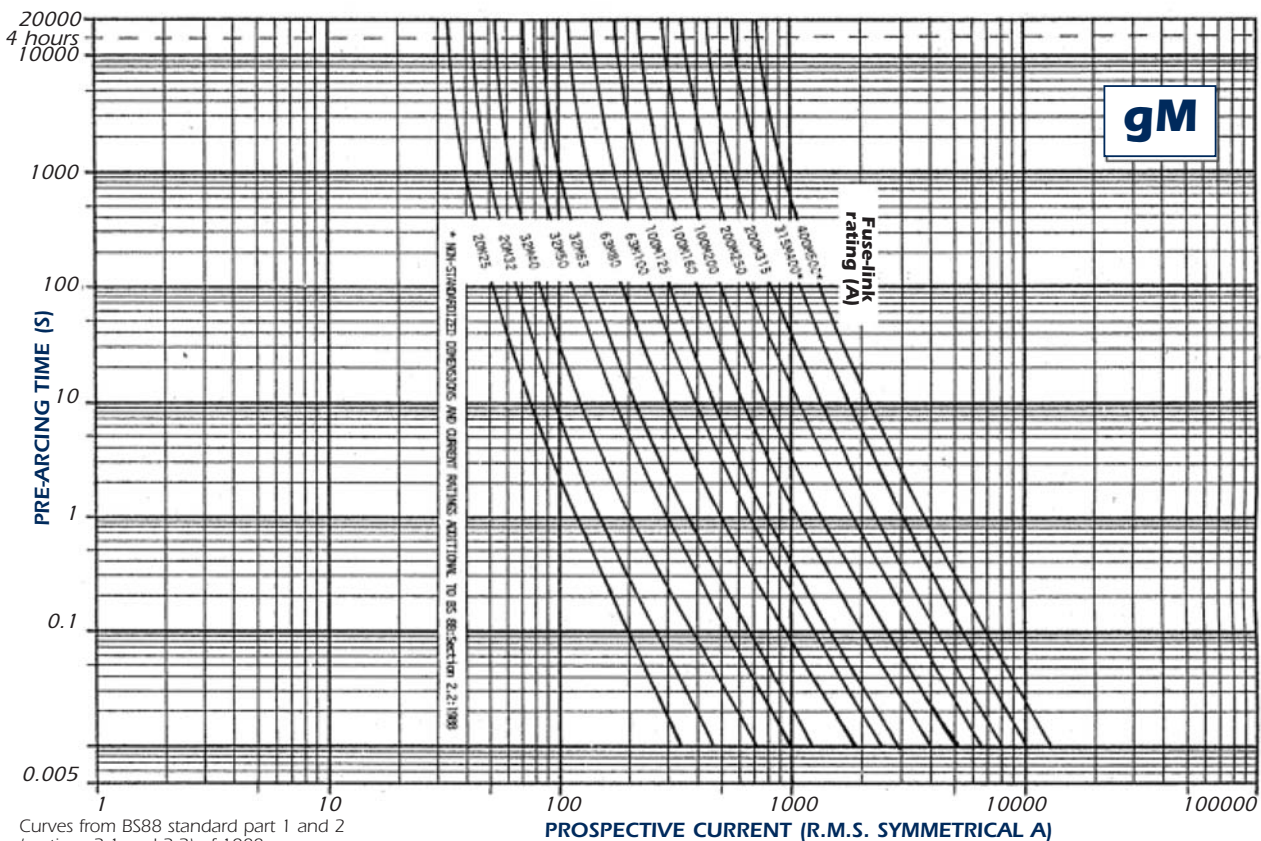
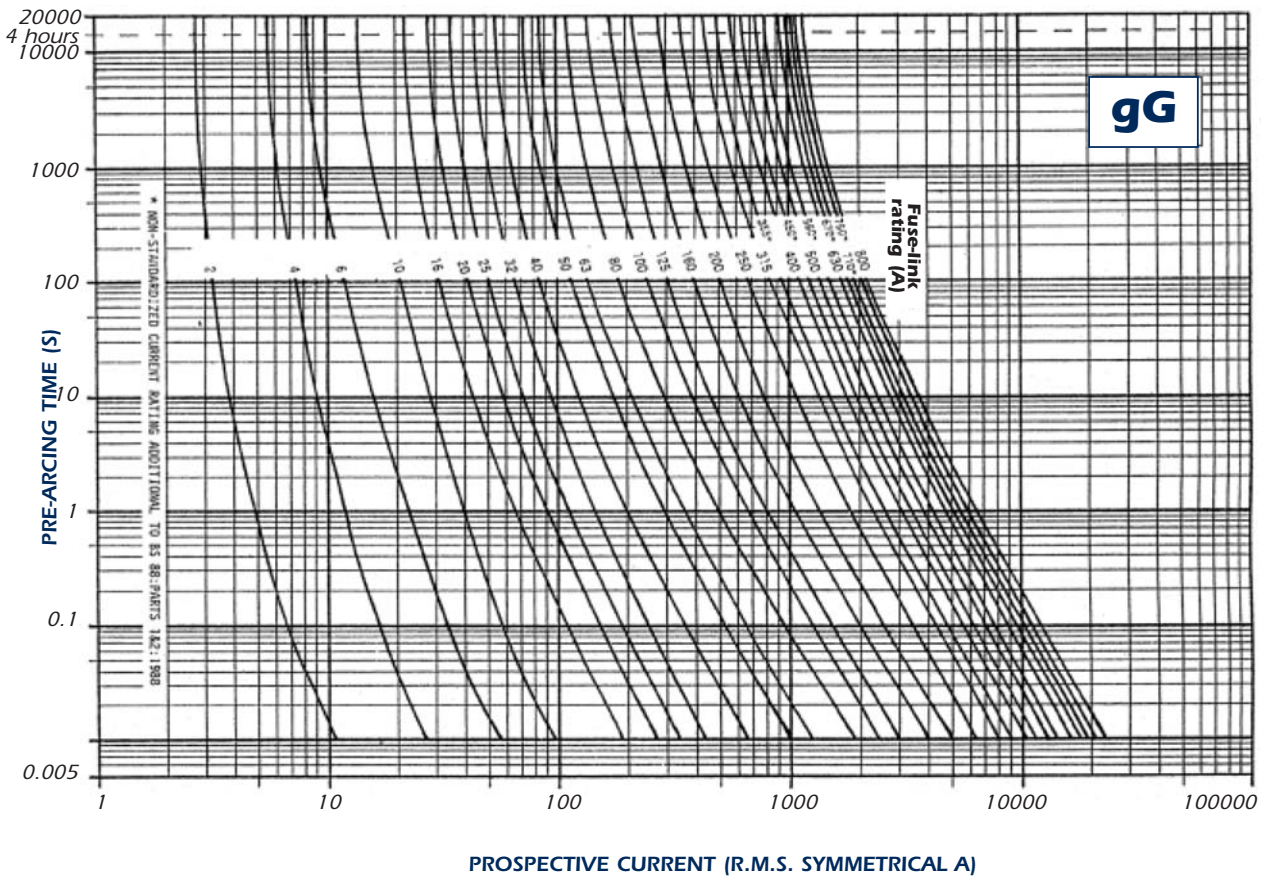

Curves from BS88 standard part 1 and 2 (sections 2.1 and 2.2) of 1988.

Voltage rating : 415 V. Interrupting rating : 80 kA under 415 V.

* Current ratings additional to BS88.

I²t characteristics

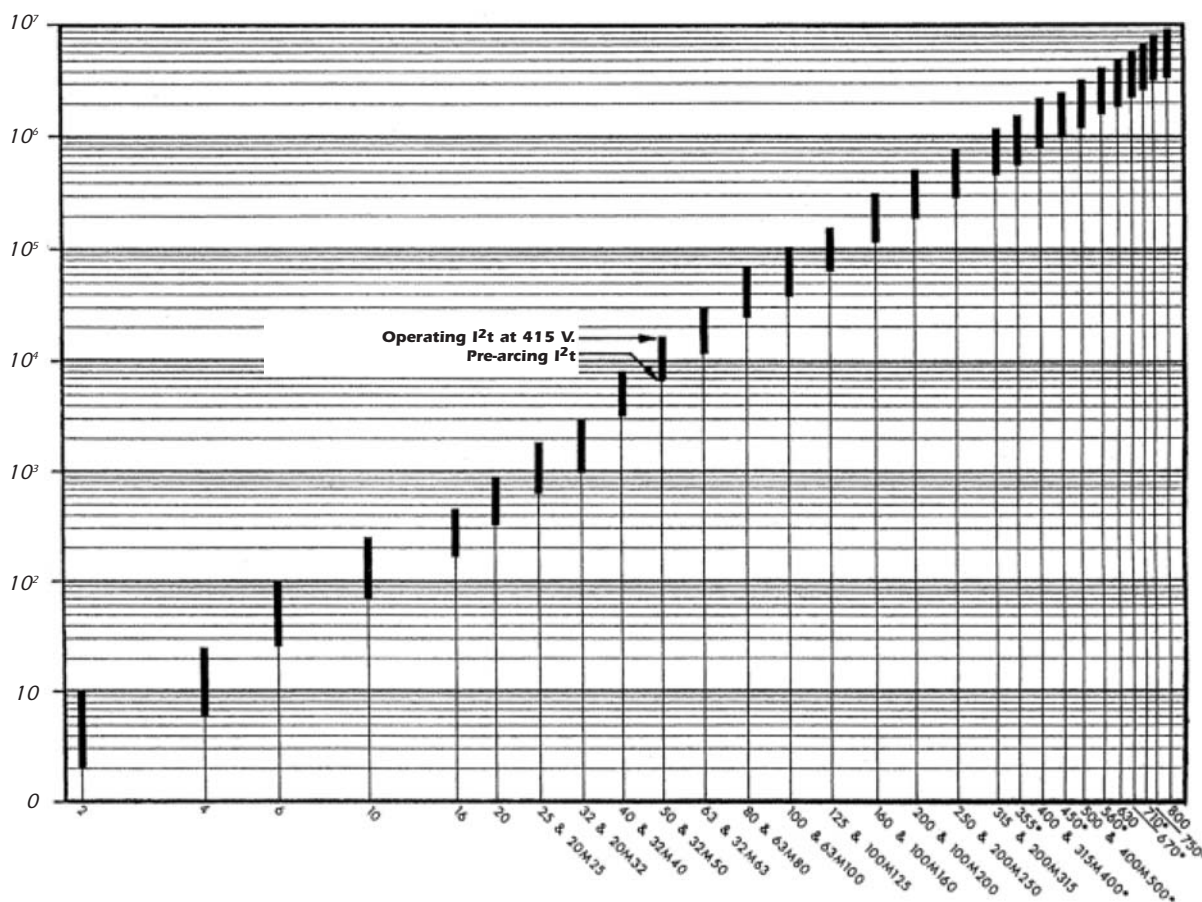

* Current ratings additional to BS88

Dissipated power

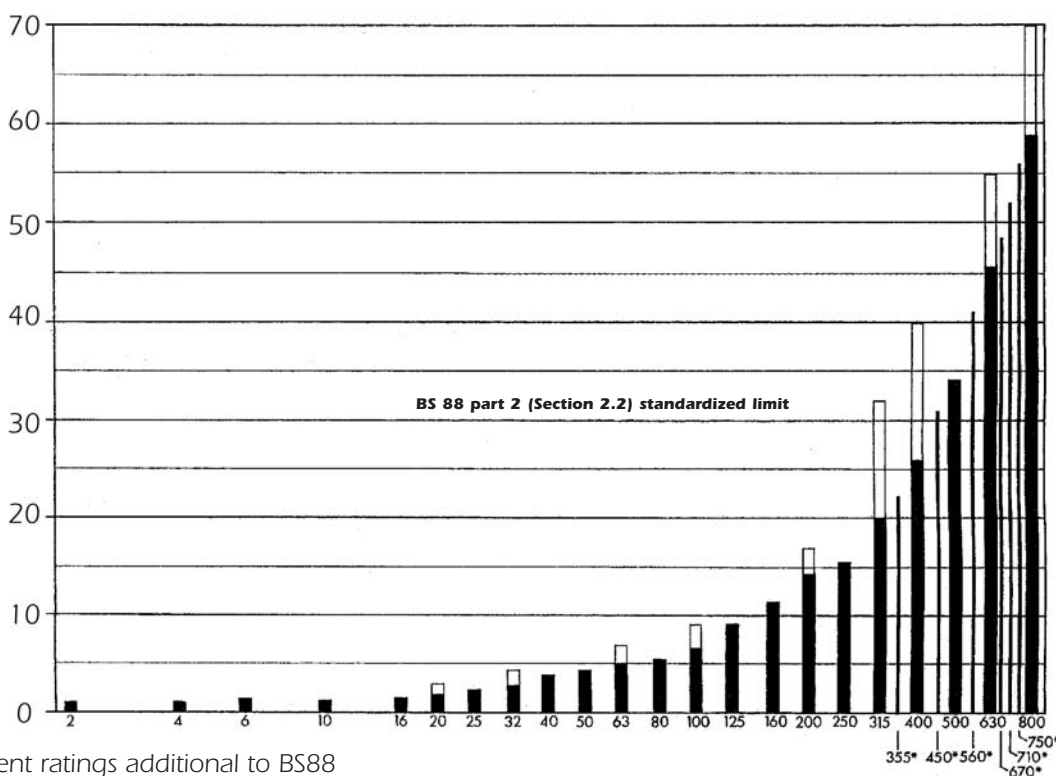

* Current ratings additional to BS88

General Purpose Fuses IEC

BS88-2 Fuses gG/gM Sizes A,B,C

Peak let-through current

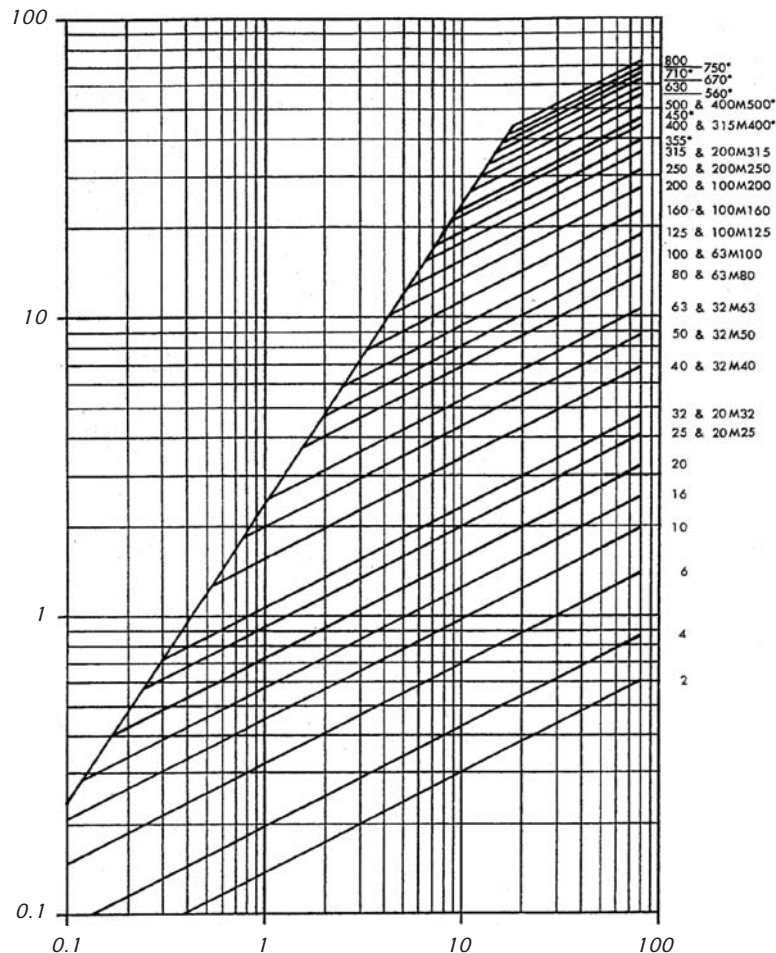

* Current ratings additional to BS88

Nominal current derating by temperature

Fuse-link rating (A)	Current carrying capability (in amperes) at elevated temperatures									
	40°C	45°C	50°C	55°C	60°C	65°C	70°C	75°C	80°C	
2, 4, 6, 10										
16										15
20									18	16
25								23	21	19
32								31	30	29
40								39	38	37
50								49	48	47
63								61	59	57
80								79	78	76
100								98	96	94
125								122	119	116
160							155	150	145	140
200							195	190	185	175
250							240	230	220	210
315							310	300	290	270
355*							345	335	320	300
400							390	380	370	350
450*							445	430	410	390
500							490	480	460	440
560*							550	530	510	490
630	620	610	590	570	550	530	510	490	470	450
670*	660	640	620	600	580	560	540	520	500	480
710*	700	680	660	640	620	600	580	560	540	520
750*	740	730	710	690	670	650	630	610	590	570
800	780	760	740	720	700	680	660	640	620	600

FUSE-LINKS FULLY RATED

- When the fuse-link is mounted in the open, the elevated temperature is the ambient air temperature (T_a).
- When the fuse-link is mounted in an enclosure, the elevated temperature is the internal "fluid environment temperature" (T_e) within the enclosure.
- When it is not known, it should be assumed to be 15°C higher than the ambient air temperature external to the enclosure, i.e. $T_e = T_a + 15^\circ\text{C}$.

Examples:

- 100A fuse-link mounted in the open at an ambient air temperature of 65°C.
Current carrying capability = 100A.
- 200A fuse-link mounted in the open at an ambient air temperature of 60°C.
Current carrying capability = 195A.
- 400A fuse-link mounted in an enclosure having an internal temperature of 65°C.
Current carrying capability = 370A.
- 800A fuse-link mounted in an enclosure with an unknown internal temperature and an external ambient air temperature of 40°C. Assume the internal temperature is 55°C (40°C + 15°C). Current carrying temperature = 740A.

Curves and derating comply with BS88 standard part 1 and 2 sections 2.1 and 2.2 of 1988.

* Derating also applies, to additional current ratings.

BS88-2 Fuses gG/gM Sizes F1,F2



- The fuse comply with standard EN 60269-2 section II and standard BS88 part 2.
- This fuses are designed for :
 - "general purpose use" protection, (gG type)
 - motor protection (gM type)
- This fuse range insures an excellent current limitation for all overloads on a large range of applications. Their size cannot allow exchange by other fuses of higher rating in the F type range. They are compact and can be connected with clips.

F1,F2 types - gG curve

Features/Benefits

- Compact design
- Curve gG and gM
- Very current limiting
- Tested in DC
- Voltage 415VAC
- High breaking capacity : 80kA @ 415VAC
- Connection by clips or appropriate fuse holders.

Ratings

▪ F1 type

from 2A to 32A

▪ F2type

from 10A to 63A

Applications

- Power cable protection
- Distribution panel protection
- Control panel
- Main circuit
- Lighting, heating and electrical equipments
- Capacitor, batteries
- Can be used with circuit breakers.

Approvals

- Asta  Certified

Fuses designations and ratings

F1 type

Type	Rating	Ref. no	Designation	Pack.	Catalog Number
F1	2	S226336	2F1	10	
F1	4	T226337	4F1	10	
F1	6	V226338	6F1	10	
F1	10	W226339	10F1	10	
F1	16	X226340	16F1	10	
F1	20	Y226341	20F1	10	
F1	25	Z226342	25F1	10	
F1	32	A226343	32F1	10	
F1*	20M25	B226344	20M25F1	10	
F1*	20M32	C226345	20M32F1	10	

F2 type

Type	Rating	Ref. no	Designation	Pack.	Catalog Number
F2	10	D226346	10F2	10	
F2	16	E226347	16F2	10	
F2	20	F226348	20F2	10	
F2	25	G226349	25F2	10	
F2	32	H226350	32F2	10	
F2	40	J226351	40F2	10	
F2	50	K226352	50F2	10	
F2	63	L226353	63F2	10	

* Selection table for gM fuses : refer to A, B and C types

General Purpose Fuses IEC

BS88-2 Fuses gG/gM Sizes F1,F2

Dimensions

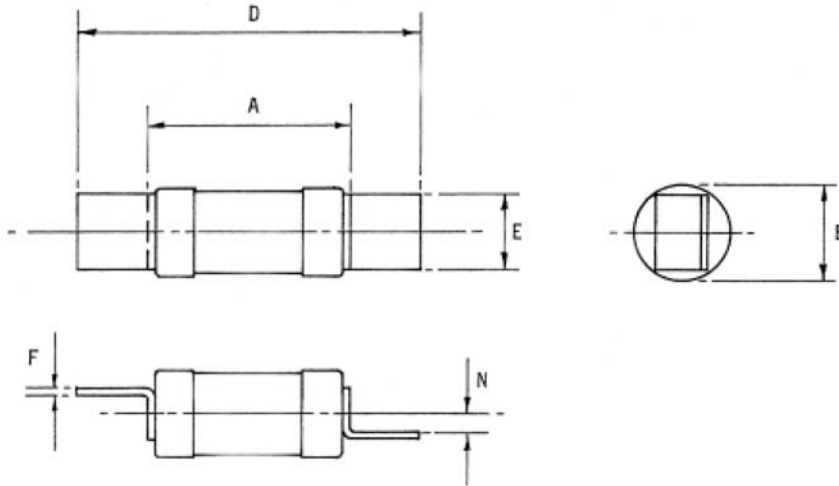

Ref. BS 88	Voltage (Vac)	Current ratings (A)	Dimensions (mm)						
			A max	B max	D max	E max	F nom	N nom	
F1	415V	2, 4, 6, 10, 16, 20, 25, 32, 20M25*, 20M32*	mm	35,5	14,3	62	11,5	0,8	3,5
			in	1-2/5	9/16	2-7/16	9/20	1/32	1/8
F2	415V	10, 16, 20, 25, 32, 40, 50, 63	mm	39	17,5	69	15	1,4	3,5
			In	1-7/13	11/16	2-13/8	9/16	1/18	1/8

* Current ratings additional to BS88 also comply to the BS 88 standard part 6 of 1988.

Time/current data

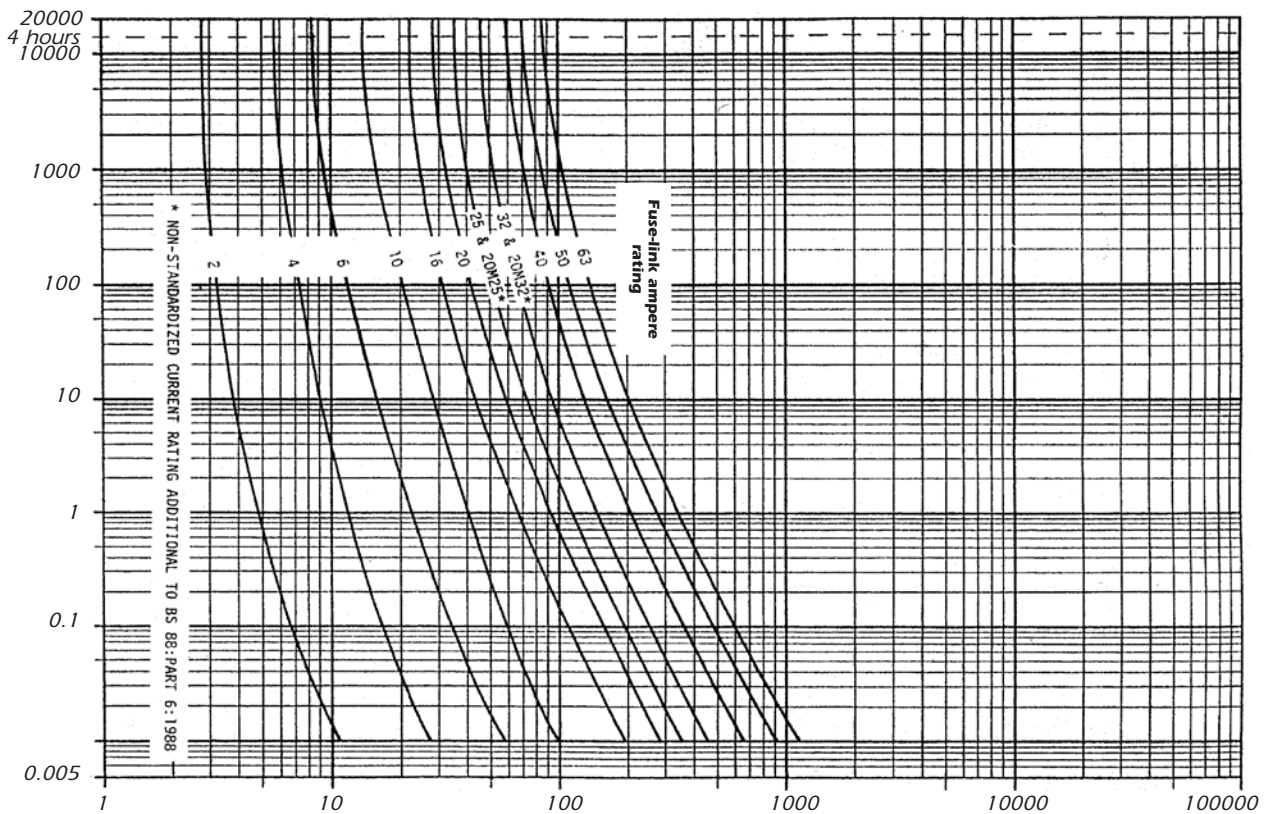

BS88-2 Fuses gG/gM Sizes F1, F2

I²t characteristics

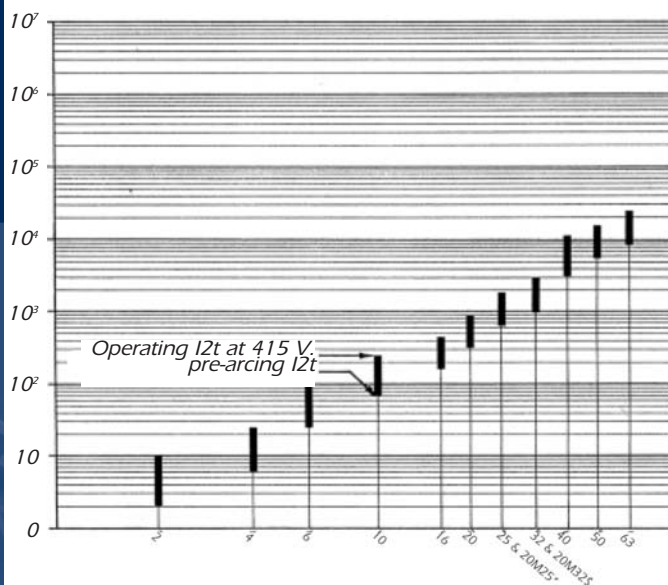

Curves from BS88 standard part 6 of 1988.

Voltage rating : 415 VAC.
Interrupting rating : 40 kA under 415 VAC.

* Current ratings additional to BS88 also comply to the BS 88 standard part 6 of 1988.

Peak let-through current

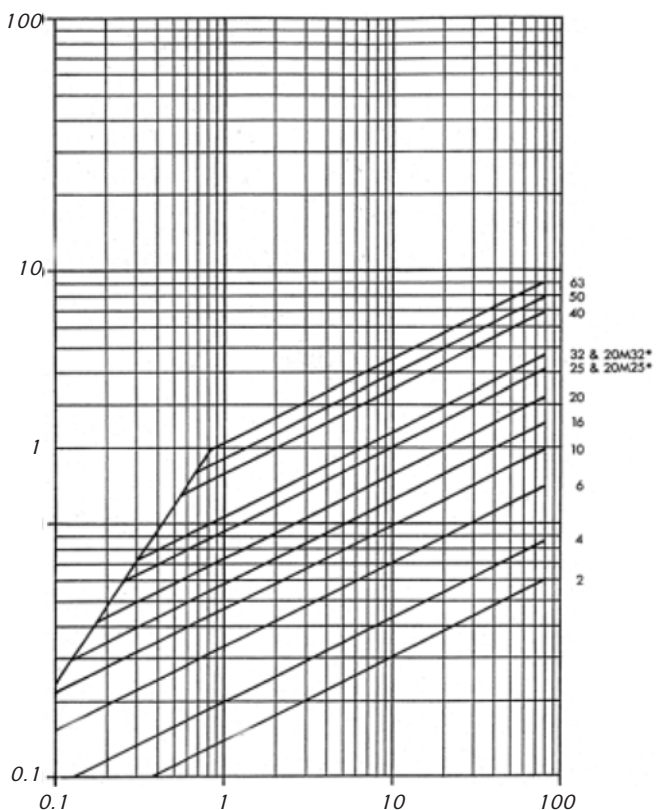

Curves from BS88 standard part 6 of 1988.

Voltage rating : 415 VAC.
Interrupting rating : 40 kA under 415 VAC.

ASTA 20 certified

* Current ratings additional to BS88 also comply to the BS 88 standard part 6 of 1988.

Dissipated power

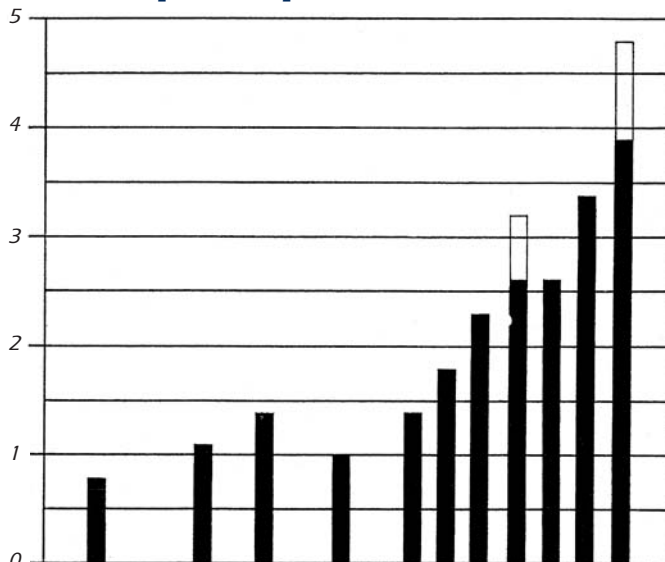

BS 88-part 6 standardized limit

Curves from BS88 standard part 6 of 1988.

Voltage rating : 415 VAC.
Interrupting rating : 40 kA under 415 VAC.

* Current ratings additional to BS88 also comply to the BS 88 standard part 6 of 1988.